

**OneNAND SPECIFICATION**

Density	Part No.	Vcc(core & IO)	Temperature	PKG
512Mb	KFG1216Q2M-DEB	1.8V(1.7V~1.95V)	Extended	63FBGA(LF)
	KFG1216D2M-DEB	2.65V(2.4V~2.9V)	Extended	63FBGA(LF)
	KFG1216U2M-DIB	3.3V(2.7V~3.6V)	Industrial	63FBGA(LF)
1Gb	KFH1G16Q2M-DEB	1.8V(1.7V~1.95V)	Extended	N/A

**Version: Ver. 1.4**

**Date: June 15th, 2005**

**INFORMATION IN THIS DOCUMENT IS PROVIDED IN RELATION TO SAMSUNG PRODUCTS,  
AND IS SUBJECT TO CHANGE WITHOUT NOTICE.  
NOTHING IN THIS DOCUMENT SHALL BE CONSTRUED AS GRANTING ANY LICENSE,  
EXPRESS OR IMPLIED, BY ESTOPPEL OR OTHERWISE,  
TO ANY INTELLECTUAL PROPERTY RIGHTS IN SAMSUNG PRODUCTS OR TECHNOLOGY. ALL  
INFORMATION IN THIS DOCUMENT IS PROVIDED  
ON AS "AS IS" BASIS WITHOUT GUARANTEE OR WARRANTY OF ANY KIND.**

1. For updates or additional information about Samsung products, contact your nearest Samsung office.
2. Samsung products are not intended for use in life support, critical care, medical, safety equipment, or similar applications where Product failure could result in loss of life or personal or physical harm, or any military or defense application, or any governmental procurement to which special terms or provisions may apply.

OneNAND™, is a trademark of Samsung Electronics Company, Ltd. Other names and brands may be claimed as the property of their rightful owners.

Copyright © 2005, Samsung Electronics Company, Ltd

Document Title

OneNAND

Revision History

<u>Revision No.</u>	<u>History</u>	<u>Draft Date</u>	<u>Remark</u>
0.0	Initial issue.	Jan. 07, 2004	Preliminary
0.0.1	1. Add the "Invalid block management" and "Error management in read and write operation" 2. Add the restriction in addressing for program operation. 3. Add the asynchronous write and latched asynchronous write mode timing diagram. 4. Define new parameters in asynchronous write mode. -tCH1 : 10ns, tCH2 : 0ns	Jan. 29, 2004	Preliminary
0.0.2	1. Add the dual operation diagram. 2. Add the block replacement diagram	Jan. 30, 2004	Preliminary
0.0.3	1. Edit the block replacement diagram 2. Add the 3.3V product.	Feb. 03, 2004	Preliminary
0.1	1. Excluded Cache Program Operation 2. Added the descriptions for below operations - Reset - Write Protection - Burst Read Latency - Dual Operation - Invalid block definition and Identification method - Error in write or read operation - ECC 3. Revised program sequence 4. Some AC parameters are changed. tACH : 9ns-->7ns, tCES : 7ns-->9ns, tAAVDS : 5ns-->7ns tDS : 30ns-->10ns, tDH : 0ns-->4ns 5. Define new AC parameter. tAWES(Address hold time in AVD low case of asynchronous write mode) Min. 0ns	Feb.11, 2004	Preliminary
0.1.1	1. Correct an errata Ball pitch of package is corrected. 0.5mm --> 0.8mm  2. Edit the timing diagram of burst read wrap around.(Figure 23,24)	Mar.9, 2004	Preliminary
0.2	1. The specification of 2.7V device is added.	Mar. 22, 2004	Preliminary
0.3	1. The specification of 3.3V device is deleted. 2. Correct some typos.	Mar. 31, 2004	Preliminary

The attached datasheets are prepared and approved by SAMSUNG Electronics. SAMSUNG Electronics CO., LTD. reserve the right to change the specifications. SAMSUNG Electronics will evaluate and reply to your requests and questions about device. If you have any questions, please contact the SAMSUNG branch office near you.

Document Title

OneNAND

Revision History

<u>Revision No.</u>	<u>History</u>	<u>Draft Date</u>	<u>Remark</u>
0.4	<ol style="list-style-type: none"> <li>1. Corrected the errata</li> <li>2. Added spare assignment information in detail</li> <li>3. Added NAND array memory map</li> <li>4. Added manufacturer ID for CS as 00ECh</li> <li>5. Added stepping ID for CS in version ID register</li> <li>6. Divided default status of interrupt status register by Warm, Hot reset and Cold reset</li> <li>7. Revised Load operation flow chart</li> <li>8. Revised Program operation flow chart</li> <li>9. Deleted DBS setting step in Copy-back operation</li> <li>10. Added OTP description</li> <li>11. Revised OTP Load and Program flow chart</li> <li>12. Added INT guidance</li> <li>13. ECC description is revised</li> <li>14. Added Data Protection Scheme during Power-down</li> <li>15. Added DC/AC parameters</li> </ol>	June 22, 2004	Preliminary
1.0	<ol style="list-style-type: none"> <li>1. Deleted 2.7V product</li> <li>2. Added 2.65V product</li> <li>3. Added 3.3V product and industrial temperature in 3.3V product</li> <li>4. Deleted Unlock/Lock BootRAM command</li> <li>5. Added DBS setting step in Copy-back operation</li> <li>6. Added 2.65V/3.3V DC parameters</li> <li>7. Revised tCES from 9ns to 7ns</li> <li>8. Deleted tOEH in asynchronous read operation</li> <li>9. Revised NOP from 4 times per each main and spare in a page to 2 times per sector</li> <li>10. Revised Write Protection status description</li> <li>11. Added DDP selection and operation guidance</li> <li>12. Added 1Gb DDP device ID</li> <li>13. Added INT bit status in Cold Reset operation</li> <li>14. Moved Interrupt register setting before inputting command in all flow charts</li> <li>15. Revised Dual operation diagrams</li> <li>16. Added and revised the asynchronous read operation timing diagram</li> <li>17. Revised the asynchronous write operation timing diagram</li> <li>18. Added the tREADY parameter in Hot Reset operation</li> </ol>	August 5, 2004	Final
1.1	<ol style="list-style-type: none"> <li>1. Revised standby current for DDP</li> </ol>	August 26, 2004	Final
1.2	<ol style="list-style-type: none"> <li>1. Corrected DDP device ID</li> <li>2. Excluded Commercial Temperature range</li> <li>3. Revised Cold Reset timing diagram</li> <li>4. Added CE and RDY in Warm Reset diagram</li> <li>5. Excluded Write while Load and Read while Program operation</li> <li>6. Revised Extended Temperature minimum value from -25 to -30</li> <li>7. Revised typical tOTP, tLOCK from 300us to 600us</li> <li>8. Revised max tOTP, tLOCK from 600us to 1000us</li> <li>9. Revised Icc4, Icc5 test condition</li> <li>10. Added Endurance and Data Retention</li> </ol>	October 26, 2004	

The attached datasheets are prepared and approved by SAMSUNG Electronics. SAMSUNG Electronics CO., LTD. reserve the right to change the specifications. SAMSUNG Electronics will evaluate and reply to your requests and questions about device. If you have any questions, please contact the SAMSUNG branch office near you.

Document Title

OneNAND

Revision History

<u>Revision No.</u>	<u>History</u>	<u>Draft Date</u>	<u>Remark</u>
1.3	<ol style="list-style-type: none"> <li>1. Deleted Manufacturer ID for ES</li> <li>2. Excluded bit error case in Load operation</li> <li>3. Revised tWEA value from max to min</li> <li>4. Revised tRD1 typical value from 35us to 40us</li> <li>5. Revised tRD2 typical value from 75us to 85us</li> <li>6. Added technical note for OneNAND boot sequence</li> <li>7. Revised Asynchronous Read timing diagram for <math>\overline{CE}</math> don't care mode</li> <li>8. Revised Asynchronous Write timing diagram for <math>\overline{CE}</math> don't care mode</li> <li>9. Revised Load operation timing diagram for <math>\overline{CE}</math> don't care mode</li> </ol>	Dec. 16, 2004	Final
1.4	<ol style="list-style-type: none"> <li>1. Added Copyright Notice in the beginning</li> <li>2. Corrected Errata</li> <li>3. Updated Icc2, Icc4, Icc5, Icc6 and I<sub>SB</sub></li> <li>4. Revised INT pin description</li> <li>5. Changed default of Manufacturer ID Register with 00ECh</li> <li>6. Removed "or erase case, refer to the table 3" from descriptions of WB, EB</li> <li>7. Added OTP erase case NOTE</li> <li>8. Revised case definitions of Interrupt Status Register</li> <li>9. Added a NOTE to Command register</li> <li>10. Added ECClogSector Information table</li> <li>11. Removed 'data unit based data handling' from description of Device Operation</li> <li>12. Revised description on Warm/Hot/NAND Flash Core Reset</li> <li>13. Revised Warm Reset Timing</li> <li>14. Revised description for 4-, 8-, 16-, 32-Word Linear Burst Mode</li> <li>15. Revised OTP operation description</li> <li>16. Restored earlier text for OTP Programming</li> <li>17. Added supplemental explanation for ECC Operation</li> <li>18. Replaced "read" with "load" in ECC bypass</li> <li>19. Removed redundant sentence from ECC Bypass Operation</li> <li>20. Added technical note for INT pin connection guide</li> </ol>	Jun. 15, 2005	

The attached datasheets are prepared and approved by SAMSUNG Electronics. SAMSUNG Electronics CO., LTD. reserve the right to change the specifications. SAMSUNG Electronics will evaluate and reply to your requests and questions about device. If you have any questions, please contact the SAMSUNG branch office near you.

**1. FEATURES****◆ Architecture**

- Design Technology: 0.12um
- Voltage Supply
  - 1.8V device(KFG1216Q2M) : 1.7V~1.95V
  - 2.65V device(KFG1216D2M) : 2.4V~2.9V
  - 3.3V device(KFG1216U2M) : 2.7V~3.6V
- Organization
  - Host Interface:16bit
- Internal BufferRAM(5K Bytes)
  - 1KB for BootRAM, 4KB for DataRAM
- NAND Array
  - Page Size : (2K+64)bytes
  - Block Size : (128K+4K)bytes

**◆ Performance**

- Host Interface type
  - Synchronous Burst Read
    - : Clock Frequency: up to 54MHz
    - : Linear Burst - 4, 8, 16, 32 words with wrap-around
    - : Continuous Sequential Burst(1K words)
  - Asynchronous Random Read
    - : Access time of 76ns
  - Asynchronous Random Write
- Programmable Read latency
- Multiple Sector Read
  - Read multiple sectors by Sector Count Register(up to 4 sectors)
- Reset Mode
  - Cold Reset / Warm Reset / Hot Reset / NAND Flash Reset
- Power dissipation (typical values)
  - Standby current : 10uA@1.8V, 20uA@2.65V/3.3V for single, 20uA@1.8V, 40uA@2.65V/3.3V for DDP
  - Synchronous Burst Read current(54MHz) : 12mA@1.8V device, 20mA@2.65V/3.3V device
  - Load current : 20mA@1.8V device, 25mA@2.65V/3.3V device
  - Program current: 20mA@1.8V device, 25mA@2.65V/3.3V device
  - Erase current: 15mA@1.8V device, 20mA@2.65V/3.3V device
- Reliable CMOS Floating-Gate Technology
  - Endurance : 100K Program/Erase Cycles
  - Data Retention : 10 Years

**◆ Hardware Features**

- Voltage detector generating internal reset signal from Vcc
- Hardware reset input ( $\overline{RP}$ )
- Data Protection
  - Write Protection for BootRAM
  - Write Protection mode for NAND Flash Array
  - Write protection during power-up
  - Write protection during power-down
- User-controlled One Time Programmable(OTP) area
- Internal 2bit EDC / 1bit ECC
- Internal Bootloader supports Booting Solution in system

**◆ Software Features**

- Handshaking Feature
  - INT pin: Indicates Ready / Busy of OneNAND
  - Polling method: Provides a software method of detecting the Ready / Busy status of OneNAND
- Detailed chip information by ID register

**◆ Packaging**

- Package
  - 63ball, 9.5mm x 12mm x max 1.0mm t , 0.8mm ball pitch FBGA

**2. GENERAL DESCRIPTION**

OneNAND is a single-die chip with standard NOR Flash interface using NAND Flash Array. This device is comprised of logic and NAND Flash Array and 5KB internal BufferRAM. 1KB BootRAM is used for reserving bootcode, and 4KB DataRAM is used for buffering data. The operating clock frequency is up to 54MHz. This device is X16 interface with Host, and has the speed of ~76ns random access time. Actually, it is accessible with minimum 4clock latency(host-driven clock for synchronous read), but this device adopts the appropriate wait cycles by programmable read latency. OneNAND provides the multiple sector read operation by assigning the number of sectors to be read in the sector counter register. The device includes one block sized OTP(One Time Programmable), which can be used to increase system security or to provide identification capabilities.

## 3. PIN DESCRIPTION

Pin Name	Type	Name and Description
<b>Host Interface</b>		
A15~A0	I	<b>Address Inputs</b> - Inputs for addresses during read operation, which are for addressing BufferRAM & Register.
DQ15~DQ0	I/O	<b>Data Inputs/Outputs</b> - Inputs data during program and commands during all operations, outputs data during memory array/register read cycles. Data pins float to high-impedance when the chip is deselected or outputs are disabled.
INT	O	<b>Interrupt</b> Notifying Host when a command has completed. It is open drain output with internal resistor (~50kohms). After power-up, it is at hi-z condition. Once IOBE is set to 1, it does not float to hi-z condition even when the chip is deselected or when outputs are disabled.
RDY	O	<b>Ready</b> Indicates data valid in synchronous read modes and is activated while $\overline{CE}$ is low
CLK	I	<b>Clock</b> CLK synchronizes the device to the system bus frequency in synchronous read mode. The first rising edge of CLK in conjunction with $\overline{AVD}$ low latches address input.
$\overline{WE}$	I	<b>Write Enable</b> $\overline{WE}$ controls writes to the bufferRAM and registers. Datas are latched on the $\overline{WE}$ pulse's rising edge
$\overline{AVD}$	I	<b>Address Valid Detect</b> Indicates valid address presence on address inputs. During asynchronous read operation, all addresses are latched on $\overline{AVD}$ 's rising edge, and during synchronous read operation, all addresses are latched on CLK's rising edge while $\overline{AVD}$ is held low for one clock cycle. > Low : for asynchronous mode, indicates valid address ;for burst mode, causes starting address to be latched on rising edge on CLK > High : device ignores address inputs
$\overline{RP}$	I	<b>Reset Pin</b> When low, $\overline{RP}$ resets internal operation of OneNAND. $\overline{RP}$ status is don't care during power-up and bootloading.
$\overline{CE}$	I	<b>Chip Enable</b> $\overline{CE}$ -low activates internal control logic, and $\overline{CE}$ -high deselected the device, places it in standby state, and places A/DQ in Hi-Z
$\overline{OE}$	I	<b>Output Enable</b> $\overline{OE}$ -low enables the device's output data buffers during a read cycle.
<b>Power Supply</b>		
Vcc-Core/Vcc		<b>Power for OneNAND Core</b> This is the power supply for OneNAND Core.
Vcc-IO/Vccq		<b>Power for OneNAND I/O</b> This is the power supply for OneNAND I/O Vcc-IO is internally connected to Vcc-Core, thus should be connected to the same power supply.
Vss		<b>Ground for OneNAND</b>
<b>etc.</b>		
DNU		<b>Do Not Use</b> Leave it disconnected. These pins are used for testing.
NC		<b>No Connection</b> Lead is not internally connected.

**NOTE:**

Do not leave power supply(VCC, VSS) disconnected.

4. PIN CONFIGURATION

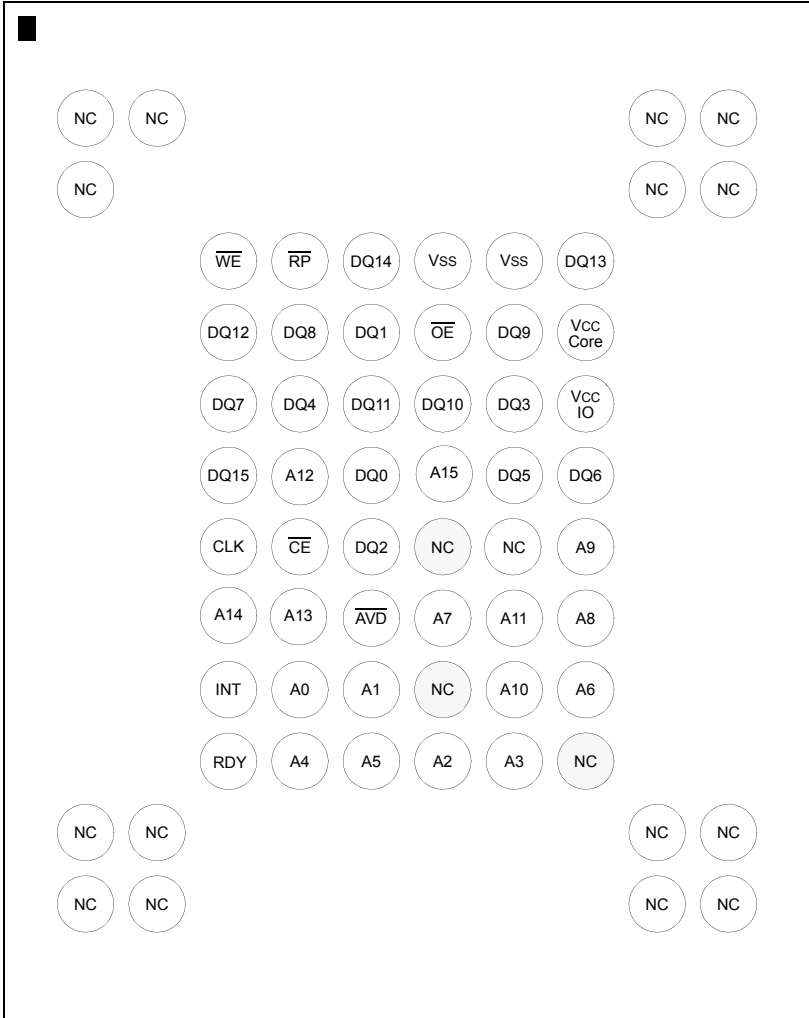

(TOP VIEW, Balls Facing Down)  
63ball FBGA OneNAND Chip  
63ball, 9.5mm x 12mm x max 1.0mmt , 0.8mm ball pitch FBGA

## DEFINITIONS

B (capital letter)	Byte, 8bits
W (capital letter)	Word, 16bits
b (lower-case letter)	Bit
ECC	Error Correction Code
Calculated ECC	ECC which has been calculated during load or program access
Written ECC	ECC which has been stored as data in the NAND Flash Array or in the BufferRAM
BufferRAM	On-chip Internal Buffer consisting of BootRAM and DataRAM
BootRAM	A 1KB portion of the BufferRAM reserved for Bootcode buffering
DataRAM	A 4KB portion of the BufferRAM reserved for Data buffering
Memory	NAND Flash array which is embedded on OneNAND
Sector	Partial unit of page, of which size is 512B for main area and 16B for spare area data. It is the minimum Load/Program/Copy-Back program unit while one~four sector operation is available
Data unit	Possible data unit to be read from memory to BufferRAM or to be programmed to memory. <ul style="list-style-type: none"> <li>- 528B of which 512B is in main area and 16B in spare area</li> <li>- 1056B of which 1024B is in main area and 32B in spare area</li> <li>- 1584B of which 1536B is in main area and 48B in spare area</li> <li>- 2112B of which 2048B is in main area and 64B in spare area</li> </ul>

5. BLOCK DIAGRAM

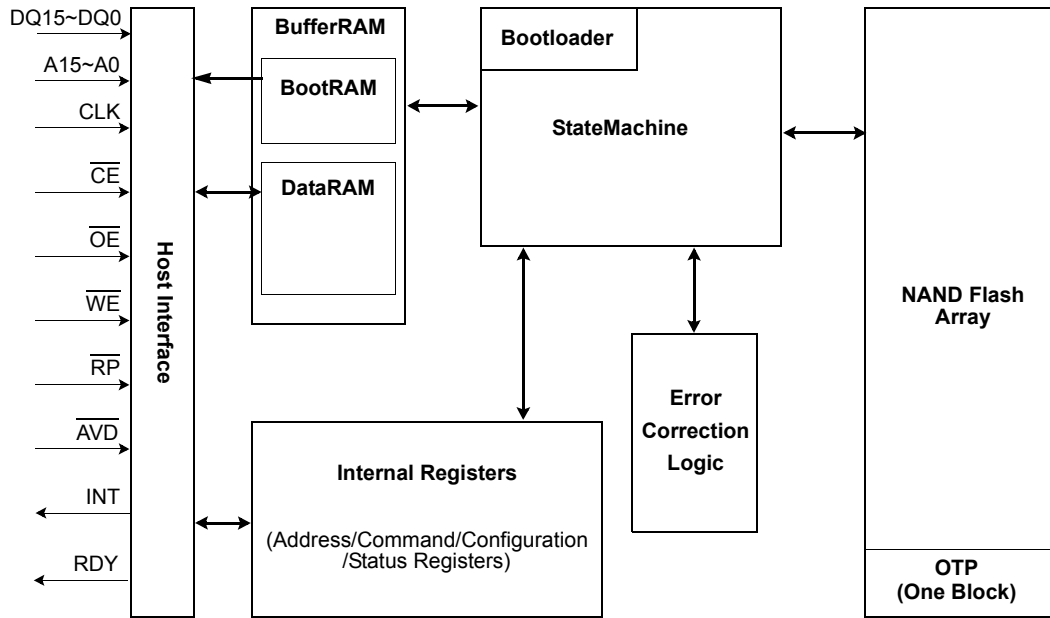

- Host Interface
- BufferRAM(BootRAM, DataRAM)
- Command and status registers
- State Machine (Bootloader is included)
- Error Correction Logic
- Memory(NAND Flash Array, OTP)

**NOTE:**

1) At cold reset, bootloader copies boot code(1K byte size) from NAND Flash Array to BootRAM.

Figure 1. Internal Block Diagram

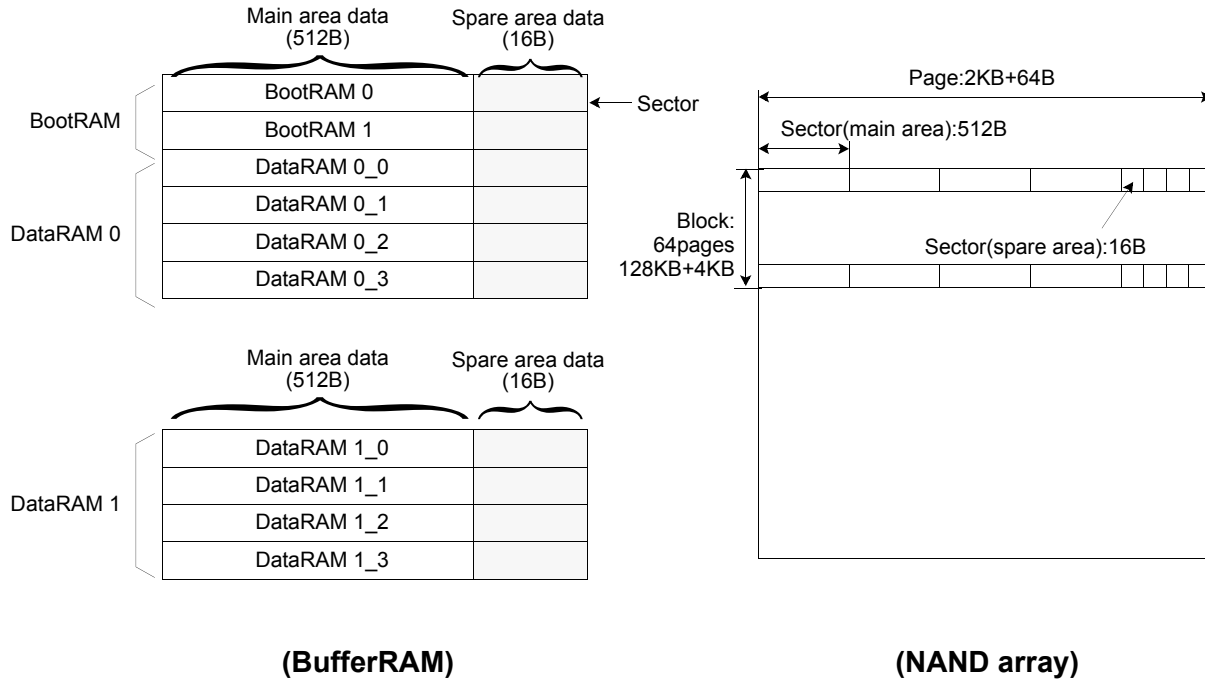
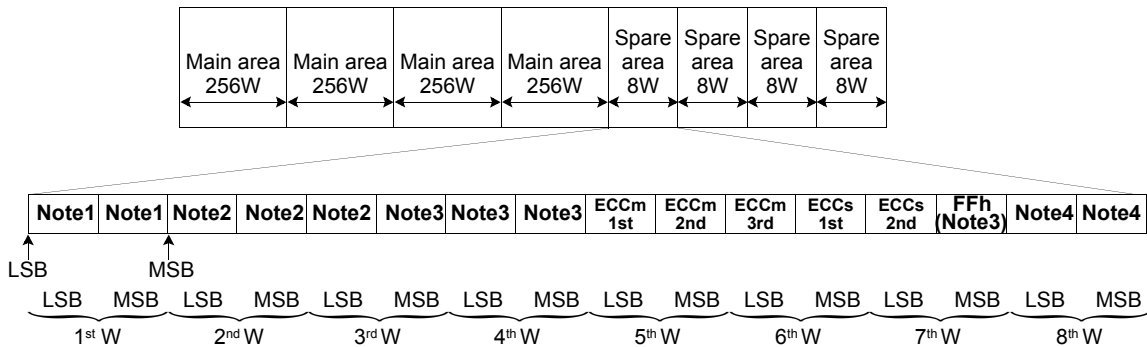

Figure 2. BufferRAM and NAND array structure



**NOTE:**

- 1) The 1st word of spare area in 1st and 2nd page of every invalid block is reserved for the invalid block information by manufacturer. Please refer to page 64 about the details.
- 2) These words are managed by internal ECC logic. So it is recommended that the important data like LSN(Logical Sector Number) are written.
- 3) These words are reserved for the future purpose by manufacturer. These words will be dedicated to internal logic.
- 4) These words are for free usage.
- 5) The 5th, 6th and 7th words are dedicated to internal ECC logic. So these words are only readable. The other words are programmable by command.
- 6) ECCm 1st, ECCm 2nd, ECCm 3rd: ECC code for Main area data
- 7) ECCs 1st, ECCs 2nd: ECC code for 2nd and 3rd word of spare area.

Figure 3. Spare area of NAND array assignment

6.1 ADDRESS MAP For OneNAND

Division	Address (word order)	Address (byte order)	Size (total 128KB)		Usage	Description
Main area (64KB)	0000h~00FFh	00000h~001FEh	512B	1KB	BootM 0	BootRAM Main sector0
	0100h~01FFh	00200h~003FEh	512B		BootM 1	BootRAM Main sector1
	0200h~02FFh	00400h~005FEh	512B	4KB	DataM 0_0	DataRAM Main page0/sector0
	0300h~03FFh	00600h~007FEh	512B		DataM 0_1	DataRAM Main page0/sector1
	0400h~04FFh	00800h~009FEh	512B		DataM 0_2	DataRAM Main page0/sector2
	0500h~05FFh	00A00h~00BFEh	512B		DataM 0_3	DataRAM Main page0/sector3
	0600h~06FFh	00C00h~00DFEh	512B		DataM 1_0	DataRAM Main page1/sector0
	0700h~07FFh	00E00h~00FFEh	512B		DataM 1_1	DataRAM Main page1/sector1
	0800h~08FFh	01000h~011FEh	512B		DataM 1_2	DataRAM Main page1/sector2
	0900h~09FFh	01200h~013FEh	512B		DataM 1_3	DataRAM Main page1/sector3
	0A00h~7FFFh	01400h~0FFFEh	59KB	59KB	Reserved	Reserved
Spare area (8KB)	8000h~8007h	10000h~1000Eh	16B	32B	BootS 0	BootRAM Spare sector0
	8008h~800Fh	10010h~1001Eh	16B		BootS 1	BootRAM Spare sector1
	8010h~8017h	10020h~1002Eh	16B	128B	DataS 0_0	DataRAM Spare page0/sector0
	8018h~801Fh	10030h~1003Eh	16B		DataS 0_1	DataRAM Spare page0/sector1
	8020h~8027h	10040h~1004Eh	16B		DataS 0_2	DataRAM Spare page0/sector2
	8028h~802Fh	10050h~1005Eh	16B		DataS 0_3	DataRAM Spare page0/sector3
	8030h~8037h	10060h~1006Eh	16B		DataS 1_0	DataRAM Spare page1/sector0
	8038h~803Fh	10070h~1007Eh	16B		DataS 1_1	DataRAM Spare page1/sector1
	8040h~8047h	10080h~1008Eh	16B		DataS 1_2	DataRAM Spare page1/sector2
	8048h~804Fh	10090h~1009Eh	16B		DataS 1_3	DataRAM Spare page1/sector3
	8050h~8FFFh	100A0h~11FFEh	8032B	8032B	Reserved	Reserved
Reserved (24KB)	9000h~BFFFh	12000h~17FFEh	24KB	24KB	Reserved	Reserved
Reserved (8KB)	C000h~CFFFh	18000h~19FFEh	8KB	8KB	Reserved	Reserved
Reserved (16KB)	D000h~EFFFh	1A000h~1DFFEh	16KB	16KB	Reserved	Reserved
Registers (8KB)	F000h~FFFFh	1E000h~1FFFEh	8KB	8KB	Registers	Registers

NOTE 1) Data output is unknown while host reads a register bit of reserved area

## 6.2 ADDRESS MAP For OneNAND NAND Array (word order)

Block	Block Address	Page and Sector Address	Size	Block	Block Address	Page and Sector Address	Size
Block0	0000h	0000h~00FFh	128KB	Block32	0020h	0000h~00FFh	128KB
Block1	0001h	0000h~00FFh	128KB	Block33	0021h	0000h~00FFh	128KB
Block2	0002h	0000h~00FFh	128KB	Block34	0022h	0000h~00FFh	128KB
Block3	0003h	0000h~00FFh	128KB	Block35	0023h	0000h~00FFh	128KB
Block4	0004h	0000h~00FFh	128KB	Block36	0024h	0000h~00FFh	128KB
Block5	0005h	0000h~00FFh	128KB	Block37	0025h	0000h~00FFh	128KB
Block6	0006h	0000h~00FFh	128KB	Block38	0026h	0000h~00FFh	128KB
Block7	0007h	0000h~00FFh	128KB	Block39	0027h	0000h~00FFh	128KB
Block8	0008h	0000h~00FFh	128KB	Block40	0028h	0000h~00FFh	128KB
Block9	0009h	0000h~00FFh	128KB	Block41	0029h	0000h~00FFh	128KB
Block10	000Ah	0000h~00FFh	128KB	Block42	002Ah	0000h~00FFh	128KB
Block11	000Bh	0000h~00FFh	128KB	Block43	002Bh	0000h~00FFh	128KB
Block12	000Ch	0000h~00FFh	128KB	Block44	002Ch	0000h~00FFh	128KB
Block13	000Dh	0000h~00FFh	128KB	Block45	002Dh	0000h~00FFh	128KB
Block14	000Eh	0000h~00FFh	128KB	Block46	002Eh	0000h~00FFh	128KB
Block15	000Fh	0000h~00FFh	128KB	Block47	002Fh	0000h~00FFh	128KB
Block16	0010h	0000h~00FFh	128KB	Block48	0030h	0000h~00FFh	128KB
Block17	0011h	0000h~00FFh	128KB	Block49	0031h	0000h~00FFh	128KB
Block18	0012h	0000h~00FFh	128KB	Block50	0032h	0000h~00FFh	128KB
Block19	0013h	0000h~00FFh	128KB	Block51	0033h	0000h~00FFh	128KB
Block20	0014h	0000h~00FFh	128KB	Block52	0034h	0000h~00FFh	128KB
Block21	0015h	0000h~00FFh	128KB	Block53	0035h	0000h~00FFh	128KB
Block22	0016h	0000h~00FFh	128KB	Block54	0036h	0000h~00FFh	128KB
Block23	0017h	0000h~00FFh	128KB	Block55	0037h	0000h~00FFh	128KB
Block24	0018h	0000h~00FFh	128KB	Block56	0038h	0000h~00FFh	128KB
Block25	0019h	0000h~00FFh	128KB	Block57	0039h	0000h~00FFh	128KB
Block26	001Ah	0000h~00FFh	128KB	Block58	003Ah	0000h~00FFh	128KB
Block27	001Bh	0000h~00FFh	128KB	Block59	003Bh	0000h~00FFh	128KB
Block28	001Ch	0000h~00FFh	128KB	Block60	003Ch	0000h~00FFh	128KB
Block29	001Dh	0000h~00FFh	128KB	Block61	003Dh	0000h~00FFh	128KB
Block30	001Eh	0000h~00FFh	128KB	Block62	003Eh	0000h~00FFh	128KB
Block31	001Fh	0000h~00FFh	128KB	Block63	003Fh	0000h~00FFh	128KB

Block	Block Address	Page and Sector Address	Size	Block	Block Address	Page and Sector Address	Size
Block64	0040h	0000h~00FFh	128KB	Block96	0060h	0000h~00FFh	128KB
Block65	0041h	0000h~00FFh	128KB	Block97	0061h	0000h~00FFh	128KB
Block66	0042h	0000h~00FFh	128KB	Block98	0062h	0000h~00FFh	128KB
Block67	0043h	0000h~00FFh	128KB	Block99	0063h	0000h~00FFh	128KB
Block68	0044h	0000h~00FFh	128KB	Block100	0064h	0000h~00FFh	128KB
Block69	0045h	0000h~00FFh	128KB	Block101	0065h	0000h~00FFh	128KB
Block70	0046h	0000h~00FFh	128KB	Block102	0066h	0000h~00FFh	128KB
Block71	0047h	0000h~00FFh	128KB	Block103	0067h	0000h~00FFh	128KB
Block72	0048h	0000h~00FFh	128KB	Block104	0068h	0000h~00FFh	128KB
Block73	0049h	0000h~00FFh	128KB	Block105	0069h	0000h~00FFh	128KB
Block74	004Ah	0000h~00FFh	128KB	Block106	006Ah	0000h~00FFh	128KB
Block75	004Bh	0000h~00FFh	128KB	Block107	006Bh	0000h~00FFh	128KB
Block76	004Ch	0000h~00FFh	128KB	Block108	006Ch	0000h~00FFh	128KB
Block77	004Dh	0000h~00FFh	128KB	Block109	006Dh	0000h~00FFh	128KB
Block78	004Eh	0000h~00FFh	128KB	Block110	006Eh	0000h~00FFh	128KB
Block79	004Fh	0000h~00FFh	128KB	Block111	006Fh	0000h~00FFh	128KB
Block80	0050h	0000h~00FFh	128KB	Block112	0070h	0000h~00FFh	128KB
Block81	0051h	0000h~00FFh	128KB	Block113	0071h	0000h~00FFh	128KB
Block82	0052h	0000h~00FFh	128KB	Block114	0072h	0000h~00FFh	128KB
Block83	0053h	0000h~00FFh	128KB	Block115	0073h	0000h~00FFh	128KB
Block84	0054h	0000h~00FFh	128KB	Block116	0074h	0000h~00FFh	128KB
Block85	0055h	0000h~00FFh	128KB	Block117	0075h	0000h~00FFh	128KB
Block86	0056h	0000h~00FFh	128KB	Block118	0076h	0000h~00FFh	128KB
Block87	0057h	0000h~00FFh	128KB	Block119	0077h	0000h~00FFh	128KB
Block88	0058h	0000h~00FFh	128KB	Block120	0078h	0000h~00FFh	128KB
Block89	0059h	0000h~00FFh	128KB	Block121	0079h	0000h~00FFh	128KB
Block90	005Ah	0000h~00FFh	128KB	Block122	007Ah	0000h~00FFh	128KB
Block91	005Bh	0000h~00FFh	128KB	Block123	007Bh	0000h~00FFh	128KB
Block92	005Ch	0000h~00FFh	128KB	Block124	007Ch	0000h~00FFh	128KB
Block93	005Dh	0000h~00FFh	128KB	Block125	007Dh	0000h~00FFh	128KB
Block94	005Eh	0000h~00FFh	128KB	Block126	007Eh	0000h~00FFh	128KB
Block95	005Fh	0000h~00FFh	128KB	Block127	007Fh	0000h~00FFh	128KB

Block	Block Address	Page and Sector Address	Size	Block	Block Address	Page and Sector Address	Size
Block128	0080h	0000h~00FFh	128KB	Block160	00A0h	0000h~00FFh	128KB
Block129	0081h	0000h~00FFh	128KB	Block161	00A1h	0000h~00FFh	128KB
Block130	0082h	0000h~00FFh	128KB	Block162	00A2h	0000h~00FFh	128KB
Block131	0083h	0000h~00FFh	128KB	Block163	00A3h	0000h~00FFh	128KB
Block132	0084h	0000h~00FFh	128KB	Block164	00A4h	0000h~00FFh	128KB
Block133	0085h	0000h~00FFh	128KB	Block165	00A5h	0000h~00FFh	128KB
Block134	0086h	0000h~00FFh	128KB	Block166	00A6h	0000h~00FFh	128KB
Block135	0087h	0000h~00FFh	128KB	Block167	00A7h	0000h~00FFh	128KB
Block136	0088h	0000h~00FFh	128KB	Block168	00A8h	0000h~00FFh	128KB
Block137	0089h	0000h~00FFh	128KB	Block169	00A9h	0000h~00FFh	128KB
Block138	008Ah	0000h~00FFh	128KB	Block170	00AAh	0000h~00FFh	128KB
Block139	008Bh	0000h~00FFh	128KB	Block171	00ABh	0000h~00FFh	128KB
Block140	008Ch	0000h~00FFh	128KB	Block172	00ACh	0000h~00FFh	128KB
Block141	008Dh	0000h~00FFh	128KB	Block173	00ADh	0000h~00FFh	128KB
Block142	008Eh	0000h~00FFh	128KB	Block174	00AEh	0000h~00FFh	128KB
Block143	008Fh	0000h~00FFh	128KB	Block175	00AFh	0000h~00FFh	128KB
Block144	0090h	0000h~00FFh	128KB	Block176	00B0h	0000h~00FFh	128KB
Block145	0091h	0000h~00FFh	128KB	Block177	00B1h	0000h~00FFh	128KB
Block146	0092h	0000h~00FFh	128KB	Block178	00B2h	0000h~00FFh	128KB
Block147	0093h	0000h~00FFh	128KB	Block179	00B3h	0000h~00FFh	128KB
Block148	0094h	0000h~00FFh	128KB	Block180	00B4h	0000h~00FFh	128KB
Block149	0095h	0000h~00FFh	128KB	Block181	00B5h	0000h~00FFh	128KB
Block150	0096h	0000h~00FFh	128KB	Block182	00B6h	0000h~00FFh	128KB
Block151	0097h	0000h~00FFh	128KB	Block183	00B7h	0000h~00FFh	128KB
Block152	0098h	0000h~00FFh	128KB	Block184	00B8h	0000h~00FFh	128KB
Block153	0099h	0000h~00FFh	128KB	Block185	00B9h	0000h~00FFh	128KB
Block154	009Ah	0000h~00FFh	128KB	Block186	00BAh	0000h~00FFh	128KB
Block155	009Bh	0000h~00FFh	128KB	Block187	00BBh	0000h~00FFh	128KB
Block156	009Ch	0000h~00FFh	128KB	Block188	00BCh	0000h~00FFh	128KB
Block157	009Dh	0000h~00FFh	128KB	Block189	00BDh	0000h~00FFh	128KB
Block158	009Eh	0000h~00FFh	128KB	Block190	00BEh	0000h~00FFh	128KB
Block159	009Fh	0000h~00FFh	128KB	Block191	00BFh	0000h~00FFh	128KB

Block	Block Address	Page and Sector Address	Size	Block	Block Address	Page and Sector Address	Size
Block192	00C0h	0000h~00FFh	128KB	Block224	00E0h	0000h~00FFh	128KB
Block193	00C1h	0000h~00FFh	128KB	Block225	00E1h	0000h~00FFh	128KB
Block194	00C2h	0000h~00FFh	128KB	Block226	00E2h	0000h~00FFh	128KB
Block195	00C3h	0000h~00FFh	128KB	Block227	00E3h	0000h~00FFh	128KB
Block196	00C4h	0000h~00FFh	128KB	Block228	00E4h	0000h~00FFh	128KB
Block197	00C5h	0000h~00FFh	128KB	Block229	00E5h	0000h~00FFh	128KB
Block198	00C6h	0000h~00FFh	128KB	Block230	00E6h	0000h~00FFh	128KB
Block199	00C7h	0000h~00FFh	128KB	Block231	00E7h	0000h~00FFh	128KB
Block200	00C8h	0000h~00FFh	128KB	Block232	00E8h	0000h~00FFh	128KB
Block201	00C9h	0000h~00FFh	128KB	Block233	00E9h	0000h~00FFh	128KB
Block202	00CAh	0000h~00FFh	128KB	Block234	00EAh	0000h~00FFh	128KB
Block203	00CBh	0000h~00FFh	128KB	Block235	00EBh	0000h~00FFh	128KB
Block204	00CCh	0000h~00FFh	128KB	Block236	00ECh	0000h~00FFh	128KB
Block205	00CDh	0000h~00FFh	128KB	Block237	00EDh	0000h~00FFh	128KB
Block206	00CEh	0000h~00FFh	128KB	Block238	00EEh	0000h~00FFh	128KB
Block207	00CFh	0000h~00FFh	128KB	Block239	00EFh	0000h~00FFh	128KB
Block208	00D0h	0000h~00FFh	128KB	Block240	00F0h	0000h~00FFh	128KB
Block209	00D1h	0000h~00FFh	128KB	Block241	00F1h	0000h~00FFh	128KB
Block210	00D2h	0000h~00FFh	128KB	Block242	00F2h	0000h~00FFh	128KB
Block211	00D3h	0000h~00FFh	128KB	Block243	00F3h	0000h~00FFh	128KB
Block212	00D4h	0000h~00FFh	128KB	Block244	00F4h	0000h~00FFh	128KB
Block213	00D5h	0000h~00FFh	128KB	Block245	00F5h	0000h~00FFh	128KB
Block214	00D6h	0000h~00FFh	128KB	Block246	00F6h	0000h~00FFh	128KB
Block215	00D7h	0000h~00FFh	128KB	Block247	00F7h	0000h~00FFh	128KB
Block216	00D8h	0000h~00FFh	128KB	Block248	00F8h	0000h~00FFh	128KB
Block217	00D9h	0000h~00FFh	128KB	Block249	00F9h	0000h~00FFh	128KB
Block218	00DAh	0000h~00FFh	128KB	Block250	00FAh	0000h~00FFh	128KB
Block219	00DBh	0000h~00FFh	128KB	Block251	00FBh	0000h~00FFh	128KB
Block220	00DCh	0000h~00FFh	128KB	Block252	00FCh	0000h~00FFh	128KB
Block221	00DDh	0000h~00FFh	128KB	Block253	00FDh	0000h~00FFh	128KB
Block222	00DEh	0000h~00FFh	128KB	Block254	00FEh	0000h~00FFh	128KB
Block223	00DFh	0000h~00FFh	128KB	Block255	00FFh	0000h~00FFh	128KB

Block	Block Address	Page and Sector Address	Size	Block	Block Address	Page and Sector Address	Size
Block256	0100h	0000h~00FFh	128KB	Block288	0120h	0000h~00FFh	128KB
Block257	0101h	0000h~00FFh	128KB	Block289	0121h	0000h~00FFh	128KB
Block258	0102h	0000h~00FFh	128KB	Block290	0122h	0000h~00FFh	128KB
Block259	0103h	0000h~00FFh	128KB	Block291	0123h	0000h~00FFh	128KB
Block260	0104h	0000h~00FFh	128KB	Block292	0124h	0000h~00FFh	128KB
Block261	0105h	0000h~00FFh	128KB	Block293	0125h	0000h~00FFh	128KB
Block262	0106h	0000h~00FFh	128KB	Block294	0126h	0000h~00FFh	128KB
Block263	0107h	0000h~00FFh	128KB	Block295	0127h	0000h~00FFh	128KB
Block264	0108h	0000h~00FFh	128KB	Block296	0128h	0000h~00FFh	128KB
Block265	0109h	0000h~00FFh	128KB	Block297	0129h	0000h~00FFh	128KB
Block266	010Ah	0000h~00FFh	128KB	Block298	012Ah	0000h~00FFh	128KB
Block267	010Bh	0000h~00FFh	128KB	Block299	012Bh	0000h~00FFh	128KB
Block268	010Ch	0000h~00FFh	128KB	Block300	012Ch	0000h~00FFh	128KB
Block269	010Dh	0000h~00FFh	128KB	Block301	012Dh	0000h~00FFh	128KB
Block270	010Eh	0000h~00FFh	128KB	Block302	012Eh	0000h~00FFh	128KB
Block271	010Fh	0000h~00FFh	128KB	Block303	012Fh	0000h~00FFh	128KB
Block272	0110h	0000h~00FFh	128KB	Block304	0130h	0000h~00FFh	128KB
Block273	0111h	0000h~00FFh	128KB	Block305	0131h	0000h~00FFh	128KB
Block274	0112h	0000h~00FFh	128KB	Block306	0132h	0000h~00FFh	128KB
Block275	0113h	0000h~00FFh	128KB	Block307	0133h	0000h~00FFh	128KB
Block276	0114h	0000h~00FFh	128KB	Block308	0134h	0000h~00FFh	128KB
Block277	0115h	0000h~00FFh	128KB	Block309	0135h	0000h~00FFh	128KB
Block278	0116h	0000h~00FFh	128KB	Block310	0136h	0000h~00FFh	128KB
Block279	0117h	0000h~00FFh	128KB	Block311	0137h	0000h~00FFh	128KB
Block280	0118h	0000h~00FFh	128KB	Block312	0138h	0000h~00FFh	128KB
Block281	0119h	0000h~00FFh	128KB	Block313	0139h	0000h~00FFh	128KB
Block282	011Ah	0000h~00FFh	128KB	Block314	013Ah	0000h~00FFh	128KB
Block283	011Bh	0000h~00FFh	128KB	Block315	013Bh	0000h~00FFh	128KB
Block284	011Ch	0000h~00FFh	128KB	Block316	013Ch	0000h~00FFh	128KB
Block285	011Dh	0000h~00FFh	128KB	Block317	013Dh	0000h~00FFh	128KB
Block286	011Eh	0000h~00FFh	128KB	Block318	013Eh	0000h~00FFh	128KB
Block287	011Fh	0000h~00FFh	128KB	Block319	013Fh	0000h~00FFh	128KB

Block	Block Address	Page and Sector Address	Size	Block	Block Address	Page and Sector Address	Size
Block320	0140h	0000h~00FFh	128KB	Block352	0160h	0000h~00FFh	128KB
Block321	0141h	0000h~00FFh	128KB	Block353	0161h	0000h~00FFh	128KB
Block322	0142h	0000h~00FFh	128KB	Block354	0162h	0000h~00FFh	128KB
Block323	0143h	0000h~00FFh	128KB	Block355	0163h	0000h~00FFh	128KB
Block324	0144h	0000h~00FFh	128KB	Block356	0164h	0000h~00FFh	128KB
Block325	0145h	0000h~00FFh	128KB	Block357	0165h	0000h~00FFh	128KB
Block326	0146h	0000h~00FFh	128KB	Block358	0166h	0000h~00FFh	128KB
Block327	0147h	0000h~00FFh	128KB	Block359	0167h	0000h~00FFh	128KB
Block328	0148h	0000h~00FFh	128KB	Block360	0168h	0000h~00FFh	128KB
Block329	0149h	0000h~00FFh	128KB	Block361	0169h	0000h~00FFh	128KB
Block330	014Ah	0000h~00FFh	128KB	Block362	016Ah	0000h~00FFh	128KB
Block331	014Bh	0000h~00FFh	128KB	Block363	016Bh	0000h~00FFh	128KB
Block332	014Ch	0000h~00FFh	128KB	Block364	016Ch	0000h~00FFh	128KB
Block333	014Dh	0000h~00FFh	128KB	Block365	016Dh	0000h~00FFh	128KB
Block334	014Eh	0000h~00FFh	128KB	Block366	016Eh	0000h~00FFh	128KB
Block335	014Fh	0000h~00FFh	128KB	Block367	016Fh	0000h~00FFh	128KB
Block336	0150h	0000h~00FFh	128KB	Block368	0170h	0000h~00FFh	128KB
Block337	0151h	0000h~00FFh	128KB	Block369	0171h	0000h~00FFh	128KB
Block338	0152h	0000h~00FFh	128KB	Block370	0172h	0000h~00FFh	128KB
Block339	0153h	0000h~00FFh	128KB	Block371	0173h	0000h~00FFh	128KB
Block340	0154h	0000h~00FFh	128KB	Block372	0174h	0000h~00FFh	128KB
Block341	0155h	0000h~00FFh	128KB	Block373	0175h	0000h~00FFh	128KB
Block342	0156h	0000h~00FFh	128KB	Block374	0176h	0000h~00FFh	128KB
Block343	0157h	0000h~00FFh	128KB	Block375	0177h	0000h~00FFh	128KB
Block344	0158h	0000h~00FFh	128KB	Block376	0178h	0000h~00FFh	128KB
Block345	0159h	0000h~00FFh	128KB	Block377	0179h	0000h~00FFh	128KB
Block346	015Ah	0000h~00FFh	128KB	Block378	017Ah	0000h~00FFh	128KB
Block347	015Bh	0000h~00FFh	128KB	Block379	017Bh	0000h~00FFh	128KB
Block348	015Ch	0000h~00FFh	128KB	Block380	017Ch	0000h~00FFh	128KB
Block349	015Dh	0000h~00FFh	128KB	Block381	017Dh	0000h~00FFh	128KB
Block350	015Eh	0000h~00FFh	128KB	Block382	017Eh	0000h~00FFh	128KB
Block351	015Fh	0000h~00FFh	128KB	Block383	017Fh	0000h~00FFh	128KB

Block	Block Address	Page and Sector Address	Size	Block	Block Address	Page and Sector Address	Size
Block384	0180h	0000h~00FFh	128KB	Block416	01A0h	0000h~00FFh	128KB
Block385	0181h	0000h~00FFh	128KB	Block417	01A1h	0000h~00FFh	128KB
Block386	0182h	0000h~00FFh	128KB	Block418	01A2h	0000h~00FFh	128KB
Block387	0183h	0000h~00FFh	128KB	Block419	01A3h	0000h~00FFh	128KB
Block388	0184h	0000h~00FFh	128KB	Block420	01A4h	0000h~00FFh	128KB
Block389	0185h	0000h~00FFh	128KB	Block421	01A5h	0000h~00FFh	128KB
Block390	0186h	0000h~00FFh	128KB	Block422	01A6h	0000h~00FFh	128KB
Block391	0187h	0000h~00FFh	128KB	Block423	01A7h	0000h~00FFh	128KB
Block392	0188h	0000h~00FFh	128KB	Block424	01A8h	0000h~00FFh	128KB
Block393	0189h	0000h~00FFh	128KB	Block425	01A9h	0000h~00FFh	128KB
Block394	018Ah	0000h~00FFh	128KB	Block426	01AAh	0000h~00FFh	128KB
Block395	018Bh	0000h~00FFh	128KB	Block427	01ABh	0000h~00FFh	128KB
Block396	018Ch	0000h~00FFh	128KB	Block428	01ACh	0000h~00FFh	128KB
Block397	018Dh	0000h~00FFh	128KB	Block429	01ADh	0000h~00FFh	128KB
Block398	018Eh	0000h~00FFh	128KB	Block430	01AEh	0000h~00FFh	128KB
Block399	018Fh	0000h~00FFh	128KB	Block431	01AFh	0000h~00FFh	128KB
Block400	0190h	0000h~00FFh	128KB	Block432	01B0h	0000h~00FFh	128KB
Block401	0191h	0000h~00FFh	128KB	Block433	01B1h	0000h~00FFh	128KB
Block402	0192h	0000h~00FFh	128KB	Block434	01B2h	0000h~00FFh	128KB
Block403	0193h	0000h~00FFh	128KB	Block435	01B3h	0000h~00FFh	128KB
Block404	0194h	0000h~00FFh	128KB	Block436	01B4h	0000h~00FFh	128KB
Block405	0195h	0000h~00FFh	128KB	Block437	01B5h	0000h~00FFh	128KB
Block406	0196h	0000h~00FFh	128KB	Block438	01B6h	0000h~00FFh	128KB
Block407	0197h	0000h~00FFh	128KB	Block439	01B7h	0000h~00FFh	128KB
Block408	0198h	0000h~00FFh	128KB	Block440	01B8h	0000h~00FFh	128KB
Block409	0199h	0000h~00FFh	128KB	Block441	01B9h	0000h~00FFh	128KB
Block410	019Ah	0000h~00FFh	128KB	Block442	01BAh	0000h~00FFh	128KB
Block411	019Bh	0000h~00FFh	128KB	Block443	01BBh	0000h~00FFh	128KB
Block412	019Ch	0000h~00FFh	128KB	Block444	01BCh	0000h~00FFh	128KB
Block413	019Dh	0000h~00FFh	128KB	Block445	01BDh	0000h~00FFh	128KB
Block414	019Eh	0000h~00FFh	128KB	Block446	01BEh	0000h~00FFh	128KB
Block415	019Fh	0000h~00FFh	128KB	Block447	01BFh	0000h~00FFh	128KB

Block	Block Address	Page and Sector Address	Size	Block	Block Address	Page and Sector Address	Size
Block448	01C0h	0000h~00FFh	128KB	Block480	01E0h	0000h~00FFh	128KB
Block449	01C1h	0000h~00FFh	128KB	Block481	01E1h	0000h~00FFh	128KB
Block450	01C2h	0000h~00FFh	128KB	Block482	01E2h	0000h~00FFh	128KB
Block451	01C3h	0000h~00FFh	128KB	Block483	01E3h	0000h~00FFh	128KB
Block452	01C4h	0000h~00FFh	128KB	Block484	01E4h	0000h~00FFh	128KB
Block453	01C5h	0000h~00FFh	128KB	Block485	01E5h	0000h~00FFh	128KB
Block454	01C6h	0000h~00FFh	128KB	Block486	01E6h	0000h~00FFh	128KB
Block455	01C7h	0000h~00FFh	128KB	Block487	01E7h	0000h~00FFh	128KB
Block456	01C8h	0000h~00FFh	128KB	Block488	01E8h	0000h~00FFh	128KB
Block457	01C9h	0000h~00FFh	128KB	Block489	01E9h	0000h~00FFh	128KB
Block458	01CAh	0000h~00FFh	128KB	Block490	01EAh	0000h~00FFh	128KB
Block459	01CBh	0000h~00FFh	128KB	Block491	01EBh	0000h~00FFh	128KB
Block460	01CCh	0000h~00FFh	128KB	Block492	01ECh	0000h~00FFh	128KB
Block461	01CDh	0000h~00FFh	128KB	Block493	01EDh	0000h~00FFh	128KB
Block462	01CEh	0000h~00FFh	128KB	Block494	01EEh	0000h~00FFh	128KB
Block463	01CFh	0000h~00FFh	128KB	Block495	01EFh	0000h~00FFh	128KB
Block464	01D0h	0000h~00FFh	128KB	Block496	01F0h	0000h~00FFh	128KB
Block465	01D1h	0000h~00FFh	128KB	Block497	01F1h	0000h~00FFh	128KB
Block466	01D2h	0000h~00FFh	128KB	Block498	01F2h	0000h~00FFh	128KB
Block467	01D3h	0000h~00FFh	128KB	Block499	01F3h	0000h~00FFh	128KB
Block468	01D4h	0000h~00FFh	128KB	Block500	01F4h	0000h~00FFh	128KB
Block469	01D5h	0000h~00FFh	128KB	Block501	01F5h	0000h~00FFh	128KB
Block470	01D6h	0000h~00FFh	128KB	Block502	01F6h	0000h~00FFh	128KB
Block471	01D7h	0000h~00FFh	128KB	Block503	01F7h	0000h~00FFh	128KB
Block472	01D8h	0000h~00FFh	128KB	Block504	01F8h	0000h~00FFh	128KB
Block473	01D9h	0000h~00FFh	128KB	Block505	01F9h	0000h~00FFh	128KB
Block474	01DAh	0000h~00FFh	128KB	Block506	01FAh	0000h~00FFh	128KB
Block475	01DBh	0000h~00FFh	128KB	Block507	01FBh	0000h~00FFh	128KB
Block476	01DCh	0000h~00FFh	128KB	Block508	01FCh	0000h~00FFh	128KB
Block477	01DDh	0000h~00FFh	128KB	Block509	01FDh	0000h~00FFh	128KB
Block478	01DEh	0000h~00FFh	128KB	Block510	01FEh	0000h~00FFh	128KB
Block479	01DFh	0000h~00FFh	128KB	Block511	01FFh	0000h~00FFh	128KB

## Detailed information of Address Map (word order)

### • BootRAM(Main area)

-0000h~01FFh: 2(sector) x 512byte(NAND main area) = 1KB

0000h~00FFh(512B) BootM 0 (sector 0 of page 0)	0100h~01FFh(512B) BootM 1 (sector 1 of page 0)
--	--

### • DataRAM(Main area)

-0200h~09FFh: 8(sector) x 512byte(NAND main area) = 4KB

0200h~02FFh(512B) DataM 0_0 (sector 0 of page 0)	0300h~03FFh(512B) DataM 0_1 (sector 1 of page 0)	0400h~04FFh(512B) DataM 0_2 (sector 2 of page 0)	0500h~05FFh(512B) DataM 0_3 (sector 3 of page 0)
0600h~06FFh(512B) DataM 1_0 (sector 0 of page 1)	0700h~07FFh(512B) DataM 1_1 (sector 1 of page 1)	0800h~08FFh(512B) DataM 1_2 (sector 2 of page 1)	0900h~09FFh(512B) DataM 1_3 (sector 3 of page 1)

### • BootRAM(Spare area)

-8000h~800Fh: 2(sector) x 16byte(NAND spare area) = 32B

8000h~8007h(16B) BootS 0 (sector 0 of page 0)	8008h~800Fh(16B) BootS 1 (sector 1 of page 0)
---	---

### • DataRAM(Spare area)

-8010h~804Fh: 8(sector) x 16byte(NAND spare area) = 128B

8010h~8017h(16B) DataS 0_0 (sector 0 of page 0)	8018h~801Fh(16B) DataS 0_1 (sector 1 of page 0)	8020h~8027h(16B) DataS 0_2 (sector 2 of page 0)	8028h~802Fh(16B) DataS 0_3 (sector 3 of page 0)
8030h~8037h(16B) DataS 1_0 (sector 0 of page 1)	8038h~803Fh(16B) DataS 1_1 (sector 1 of page 1)	8040h~8047h(16B) DataS 1_2 (sector 2 of page 1)	8048h~804Fh(16B) DataS 1_3 (sector 3 of page 1)

\*NAND Flash array consists of 2KB page size and 128KB block size.

Spare area assignment

← Equivalent to 1word of NAND Flash →

Buf.	Word Address	Byte Address	F	E	D	C	B	A	9	8	7	6	5	4	3	2	1	0
BootS 0	8000h	10000h	BI															
	8001h	10002h	Managed by Internal ECC logic															
	8002h	10004h	Reserved for the future use								Managed by Internal ECC logic							
	8003h	10006h	Reserved for the current and future use															
	8004h	10008h	ECC Code for Main area data (2 <sup>nd</sup> )								ECC Code for Main area data (1 <sup>st</sup> )							
	8005h	1000Ah	ECC Code for Spare area data (1 <sup>st</sup> )								ECC Code for Main area data (3 <sup>rd</sup> )							
	8006h	1000Ch	FFh(Reserved for the future use)								ECC Code for Spare area data (2 <sup>nd</sup> )							
	8007h	1000Eh	Free Usage															
BootS 1	8008h	10010h	BI															
	8009h	10012h	Managed by Internal ECC logic															
	800Ah	10014h	Reserved for the future use								Managed by Internal ECC logic							
	800Bh	10016h	Reserved for the current and future use															
	800Ch	10018h	ECC Code for Main area data (2 <sup>nd</sup> )								ECC Code for Main area data (1 <sup>st</sup> )							
	800Dh	1001Ah	ECC Code for Spare area data (1 <sup>st</sup> )								ECC Code for Main area data (3 <sup>rd</sup> )							
	800Eh	1001Ch	FFh(Reserved for the future use)								ECC Code for Spare area data (2 <sup>nd</sup> )							
	800Fh	1001Eh	Free Usage															
DataS 0_0	8010h	10020h	BI															
	8011h	10022h	Managed by Internal ECC logic															
	8012h	10024h	Reserved for the future use								Managed by Internal ECC logic							
	8013h	10026h	Reserved for the current and future use															
	8014h	10028h	ECC Code for Main area data (2 <sup>nd</sup> )								ECC Code for Main area data (1 <sup>st</sup> )							
	8015h	1002Ah	ECC Code for Spare area data (1 <sup>st</sup> )								ECC Code for Main area data (3 <sup>rd</sup> )							
	8016h	1002Ch	FFh(Reserved for the future use)								ECC Code for Spare area data (2 <sup>nd</sup> )							
	8017h	1002Eh	Free Usage															
DataS 0_1	8018h	10030h	BI															
	8019h	10032h	Managed by Internal ECC logic															
	801Ah	10034h	Reserved for the future use								Managed by Internal ECC logic							
	801Bh	10036h	Reserved for the current and future use															
	801Ch	10038h	ECC Code for Main area data (2 <sup>nd</sup> )								ECC Code for Main area data (1 <sup>st</sup> )							
	801Dh	1003Ah	ECC Code for Spare area data (1 <sup>st</sup> )								ECC Code for Main area data (3 <sup>rd</sup> )							
	801Eh	1003Ch	FFh(Reserved for the future use)								ECC Code for Spare area data (2 <sup>nd</sup> )							
	801Fh	1003Eh	Free Usage															

← Equivalent to 1word of NAND Flash →

Buf.	Word Address	Byte Address	F	E	D	C	B	A	9	8	7	6	5	4	3	2	1	0
DataS 0_2	8020h	10040h	BI															
	8021h	10042h	Managed by Internal ECC logic															
	8022h	10044h	Reserved for the future use								Managed by Internal ECC logic							
	8023h	10046h	Reserved for the current and future use															
	8024h	10048h	ECC Code for Main area data (2 <sup>nd</sup> )								ECC Code for Main area data (1 <sup>st</sup> )							
	8025h	1004Ah	ECC Code for Spare area data (1 <sup>st</sup> )								ECC Code for Main area data (3 <sup>rd</sup> )							
	8026h	1004Ch	FFh(Reserved for the future use)								ECC Code for Spare area data (2 <sup>nd</sup> )							
	8027h	1004Eh	Free Usage															
DataS 0_3	8028h	10050h	BI															
	8029h	10052h	Managed by Internal ECC logic															
	802Ah	10054h	Reserved for the future use								Managed by Internal ECC logic							
	802Bh	10056h	Reserved for the current and future use															
	802Ch	10058h	ECC Code for Main area data (2 <sup>nd</sup> )								ECC Code for Main area data (1 <sup>st</sup> )							
	802Dh	1005Ah	ECC Code for Spare area data (1 <sup>st</sup> )								ECC Code for Main area data (3 <sup>rd</sup> )							
	802Eh	1005Ch	FFh(Reserved for the future use)								ECC Code for Spare area data (2 <sup>nd</sup> )							
	802Fh	1005Eh	Free Usage															
DataS 1_0	8030h	10060h	BI															
	8031h	10062h	Managed by Internal ECC logic															
	8032h	10064h	Reserved for the future use								Managed by Internal ECC logic							
	8033h	10066h	Reserved for the current and future use															
	8034h	10068h	ECC Code for Main area data (2 <sup>nd</sup> )								ECC Code for Main area data (1 <sup>st</sup> )							
	8035h	1006Ah	ECC Code for Spare area data (1 <sup>st</sup> )								ECC Code for Main area data (3 <sup>rd</sup> )							
	8036h	1006Ch	FFh(Reserved for the future use)								ECC Code for Spare area data (2 <sup>nd</sup> )							
	8037h	1006Eh	Free Usage															
DataS 1_1	8038h	10070h	BI															
	8039h	10072h	Managed by Internal ECC logic															
	803Ah	10074h	Reserved for the future use								Managed by Internal ECC logic							
	803Bh	10076h	Reserved for the current and future use															
	803Ch	10078h	ECC Code for Main area data (2 <sup>nd</sup> )								ECC Code for Main area data (1 <sup>st</sup> )							
	803Dh	1007Ah	ECC Code for Spare area data (1 <sup>st</sup> )								ECC Code for Main area data (3 <sup>rd</sup> )							
	803Eh	1007Ch	FFh(Reserved for the future use)								ECC Code for Spare area data (2 <sup>nd</sup> )							
	803Fh	1007Eh	Free Usage															
DataS 1_2	8040h	10080h	BI															
	8041h	10082h	Managed by Internal ECC logic															
	8042h	10084h	Reserved for the future use								Managed by Internal ECC logic							
	8043h	10086h	Reserved for the current and future use															
	8044h	10088h	ECC Code for Main area data (2 <sup>nd</sup> )								ECC Code for Main area data (1 <sup>st</sup> )							
	8045h	1008Ah	ECC Code for Spare area data (1 <sup>st</sup> )								ECC Code for Main area data (3 <sup>rd</sup> )							
	8046h	1008Ch	FFh(Reserved for the future use)								ECC Code for Spare area data (2 <sup>nd</sup> )							
	8047h	1008Eh	Free Usage															

← Equivalent to 1word of NAND Flash →

Buf.	Word Address	Byte Address	F	E	D	C	B	A	9	8	7	6	5	4	3	2	1	0
DataS 1_3	8048h	10090h	BI															
	8049h	10092h	Managed by Internal ECC logic															
	804Ah	10094h	Reserved for the future use								Managed by Internal ECC logic							
	804Bh	10096h	Reserved for the current and future use															
	804Ch	10098h	ECC Code for Main area data (2 <sup>nd</sup> )								ECC Code for Main area data (1 <sup>st</sup> )							
	804Dh	1009Ah	ECC Code for Spare area data (1 <sup>st</sup> )								ECC Code for Main area data (3 <sup>rd</sup> )							
	804Eh	1009Ch	FFh(Reserved for the future use)								ECC Code for Spare area data (2 <sup>nd</sup> )							
	804Fh	1009Eh	Free Usage															

**NOTE:**

- BI: Bad block Information

>Host can use complete spare area except BI and ECC code area. For example,

Host can write data to Spare area buffer except for the area controlled by ECC logic at program operation.

>In case of 'with ECC' mode, OneNAND automatically generates ECC code for both main and spare data of memory during program operation but does not update ECC code to spare bufferRAM during load operation.

>When loading/programming spare area, spare area BufferRAM address(BSA) and BufferRAM sector count(BSC) is chosen via Start buffer register as it is.

## 7. Detailed address map for registers

Address (word order)	Address (byte order)	Name	Host Access	Description
F000h	1E000h	Manufacturer ID	R	Manufacturer identification
F001h	1E002h	Device ID	R	Device identification
F002h	1E004h	Version ID	R	Version identification
F003h	1E006h	Data Buffer size	R	Data buffer size
F004h	1E008h	Boot Buffer size	R	Boot buffer size
F005h	1E00Ah	Amount of buffers	R	Amount of data/boot buffers
F006h	1E00Ch	Technology	R	Info about technology used for OneNAND
F007h~F0FFh	1E00Eh~1E1FEh	Reserved	-	Reserved for user
F100h	1E200h	Start address 1	R/W	Chip address for selection of NAND Core in DDP & Block address
F101h	1E202h	Start address 2	R/W	Chip address for selection of BufferRAM in DDP
F102h	1E204h	Start address 3	R/W	Destination Block address for Copy back program
F103h	1E206h	Start address 4	R/W	Destination Page & Sector address for Copy back program
F104h	1E208h	Start address 5	-	N/A
F105h	1E20Ah	Start address 6	-	N/A
F106h	1E20Ch	Start address 7	-	N/A
F107h	1E20Eh	Start address 8	R/W	NAND Flash Page & Sector address
F108h~F1FFh	1E210h~1E3FEh	Reserved	-	Reserved for user
F200h	1E400h	Start Buffer	R/W	Buffer Number for the page data transfer to/from the OneNAND and the start Buffer Address The meaning is with which buffer to start and how many buffers to use for the data transfer
F201h~F207h	1E402h~1E40Eh	Reserved	-	Reserved for user
F208h~F21Fh	1E410h~1E43Eh	Reserved	-	Reserved for vendor specific purposes
F220h	1E440h	Command	R/W	Host control and OneNAND operation commands
F221h	1E442h	System Configuration 1	R, R/W	OneNAND and Host Interface Configuration
F222h	1E444h	System Configuration 2	-	N/A
F223h~F22Fh	1E446h~1E45Eh	Reserved	-	Reserved for user
F230h~F23Fh	1E460h~1E47Eh	Reserved	-	Reserved for vendor specific purposes
F240h	1E480h	Controller Status	R	Controller Status and result of OneNAND operation
F241h	1E482h	Interrupt	R/W	OneNAND Command Completion Interrupt Status
F242h~F24Bh	1E484h~1E496h	Reserved	-	Reserved for user
F24Ch	1E498h	Start Block Address	R/W	Start OneNAND block address to unlock in Write Protection mode
F24Dh	1E49Ah	End Block Address	R/W	End OneNAND block address to unlock in Write Protection mode
F24Eh	1E49Ch	Write Protection Status	R	Current OneNAND Write Protection status (unlocked/locked/tight-locked)
F24Fh~FEFFh	1E49Eh~1FDFEh	Reserved	-	Reserved for user

Address (word order)	Address (byte order)	Name	Host Access	Description
FF00h	1FE00h	ECC Status Register	R	ECC status of sector
FF01h	1FE02h	ECC Result of main area data	R	ECC error position of Main area data error for first selected Sector
FF02h	1FE04h	ECC Result of spare area data	R	ECC error position of Spare area data error for first selected Sector
FF03h	1FE06h	ECC Result of main area data	R	ECC error position of Main area data error for second selected Sector
FF04h	1FE08h	ECC Result of spare area data	R	ECC error position of Spare area data error for second selected Sector
FF05h	1FE0Ah	ECC Result of main area data	R	ECC error position of Main area data error for third selected Sector
FF06h	1FE0Ch	ECC Result of spare area data	R	ECC error position of Spare area data error for third selected Sector
FF07h	1FE0Eh	ECC Result of main area data	R	ECC error position of Main area data error for fourth selected Sector
FF08h	1FE10h	ECC Result of spare area data	R	ECC error position of Spare area data error for fourth selected Sector
FF09h~FFFFh	1FE12h~1FFFEh	Reserved	-	Reserved for vendor specific purposes

## 7.1 Manufacturer ID Register (R): F000h, default=00ECh

15	14	13	12	11	10	9	8	7	6	5	4	3	2	1	0
ManufID															

**ManufID** (Manufacturer ID): manufacturer identification, 00ECh for Samsung Electronics Corp.

## 7.2 Device ID Register (R): F001h, default=refer to Table1

15	14	13	12	11	10	9	8	7	6	5	4	3	2	1	0
DeviceID															

**DeviceID** (Device ID): Device Identification,

**Table 1.**

Device	DeviceID[15:0]
KFG1216Q2M	0024h
KFG1216D2M	0025h
KFG1216U2M	0025h
KFH1G16Q2M	0024h
KFH1G16D2M	0025h
KFH1G16U2M	0025h

## 7.3 Version ID Register (R): F002h

: N/A

**7.4 Data Buffer size Register(R): F003h, default=0800h**

15	14	13	12	11	10	9	8	7	6	5	4	3	2	1	0
DataBufSize															

**DataBufSize:** total data buffer size in words in the memory interface  
 Equals two buffers of 1024 words each( $2 \times 1024 = 2^N$ ,  $N=11$ )

**7.5 Boot Buffer size Register (R): F004h, default=0200h**

15	14	13	12	11	10	9	8	7	6	5	4	3	2	1	0
BootBufSize															

**BootBufSize:** total boot buffer size in words in the memory interface  
 (512 words= $2^9$ ,  $N=9$ )

**7.6 Amount of Buffers Register (R): F005h, default=0201h**

15	14	13	12	11	10	9	8	7	6	5	4	3	2	1	0
DataBufAmount								BootBufAmount							

**DataBufAmount:** the amount of data buffer= $2(2^N)$ ,  $N=1$   
**BootBufAmount:** the amount of boot buffer= $1(2^N)$ ,  $N=0$

**7.7 Technology Register (R): F006h, default=0000h**

15	14	13	12	11	10	9	8	7	6	5	4	3	2	1	0
Tech															

**Tech:** technology information, what technology is used for the memory

Tech	Technology
0000h	NAND SLC
0001h	NAND MLC
0002h-FFFFh	Reserved

7.8 Start Address1 Register (R/W): F100h, default=0000h

15	14	13	12	11	10	9	8	7	6	5	4	3	2	1	0
DFS		Reserved(000000)						FBA							

**DFS** (Device Flash Core Select): it selects Flash Core in two Flash Core of DDP  
**FBA** (NAND Flash Block Address): NAND Flash block address which will be loaded or programmed or erased.

Device	Number of Block	FBA
1Gb DDP	1024	DFS[15] & FBA[8:0]
512Mb	512	FBA[8:0]

7.9 Start Address2 Register (R/W): F101h, default=0000h

15	14	13	12	11	10	9	8	7	6	5	4	3	2	1	0
DBS		Reserved(0000000000000000)													

**DBS** (Device BufferRAM Select): it selects BufferRAM in two BufferRAM of DDP

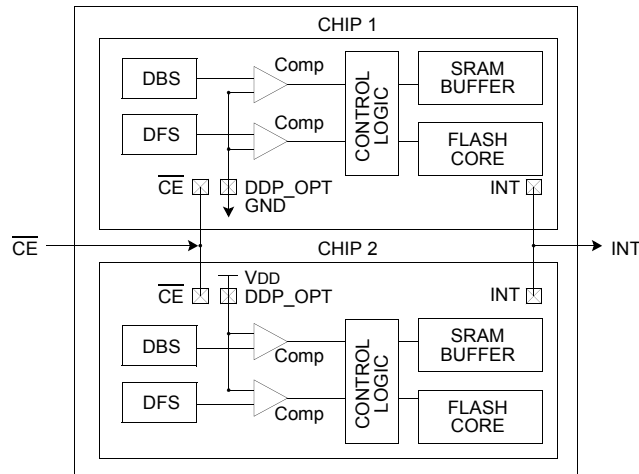

Figure 4. Chip selection method in DDP

7.10 Start Address3 Register (R/W): F102h, default=0000h

15	14	13	12	11	10	9	8	7	6	5	4	3	2	1	0
Reserved(0000000)							FCBA								

**FCBA** (NAND Flash Copy Back Block Address): NAND Flash destination block address which will be copy back programmed.

7.11 Start Address4 Register (R/W): F103h, default=0000h

15	14	13	12	11	10	9	8	7	6	5	4	3	2	1	0
Reserved(00000000)							FCPA					FCSA			

**FCPA** (NAND Flash Copy Back Page Address): NAND Flash destination page address in a block for copy back program operation.

FCPA(default value) = 000000

FCPA range : 000000~111111, 6bits for 64 pages

**FCSA** (NAND Flash Copy Back Sector Address): NAND Flash destination sector address in a page for copy back program operation.

FCSA(default value) = 00

FCSA range : 00~11, 2bits for 4 sectors

7.12 Start Address5 Register: F104h

: N/A

7.13 Start Address6 Register: F105h

: N/A

7.14 Start Address7 Register: F106h

: N/A

7.15 Start Address8 Register (R/W): F107h, default=0000h

15	14	13	12	11	10	9	8	7	6	5	4	3	2	1	0
Reserved (00000000)								FPA				FSA			

**FPA** (NAND Flash Page Address): NAND Flash start page address in a block for page load or copy back program or program operation.

FPA(default value)=000000

FPA range: 000000~111111 , 6bits for 64 pages

**FSA** (Flash Sector Address): NAND Flash start sector address in a page for read or copy back program or program operation.

FSA(default value) = 00

FSA range : 00~11, 2bits for 4 sectors

7.16 Start Buffer Register (R/W): F200h, default=0000h

15	14	13	12	11	10	9	8	7	6	5	4	3	2	1	0
Reserved(0000)				BSA				Reserved(000000)				BSC			

**BSC** (BufferRAM Sector Count): this field specifies the number of sectors to be read or programmed or copy back programmed.

Its maximum count is 4 sectors at 00(default value)value. For a single sector access, it should be programmed as value 01.

However internal RAM buffer reached to 11vaule(max value), it count up to 00 value to satisfy BSC value.

For example1) If BSA=1010, BSC=11, then selected BufferRAM are '1010 ->1011 ->1000'

There is restriction in BootRAM case.

For example2) If BSA=0000, BSC should be 01 or 10.

If BSA=0001, BSC should be 01.

**BSA** (BufferRAM Sector Address): It is the place where data is placed and specifies the sector 0~3 in the internal BootRAM and DataRAM

**BSA[3]** is the selection bit between **BootRAM** and **DataRAM**

**BSA[2]** is the selection bit between **DataRAM0** and **DataRAM1**

**BSA[1:0]** are the selection bits for sectors in a **BufferRAM**

While one of **BootRAM** or **DataRAM0** interfaces with memory, the other **RAM** is inaccessible.

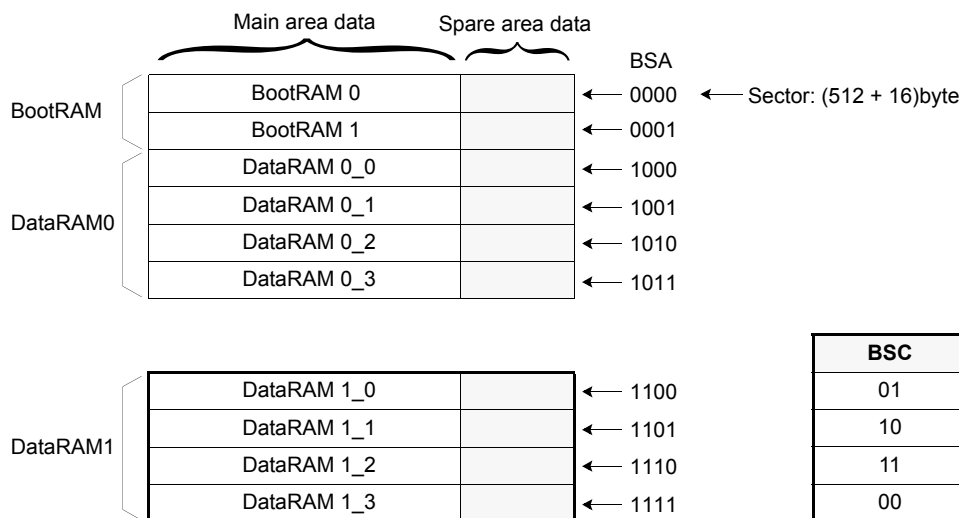

BSC	Number of Sectors
01	1 sector
10	2 sector
11	3 sector
00	4 sector

## 7.17 Command Register (R/W): F220h, default=0000h

15	14	13	12	11	10	9	8	7	6	5	4	3	2	1	0
Command															

**Command:** operation of the memory interface

CMD	Operation	Acceptable command during busy
0000h	Load single/multiple sector data unit into buffer	00F0h, 00F3h
0013h	Load single/multiple spare sector into buffer	00F0h, 00F3h
0080h	Program single/multiple sector data unit from buffer	00F0h, 00F3h
001Ah	Program single/multiple spare area sector from buffer	00F0h, 00F3h
001Bh	Copy back program	00F0h, 00F3h
0023h	Unlock NAND array block(s) from start block address to end block address	-
002Ah	Lock all NAND array block(s)	-
002Ch	Lock-tight all locked block(s)	-
0094h	Block Erase	00F0h, 00F3h
00F0h	Reset NAND Flash Core	-
00F3h	Reset OneNAND <sup>1)</sup>	-
0075h - 0065h	OTP Access	00F0h, 00F3h

**NOTE:**

1)'Reset OneNAND' (=Hot reset) command makes the registers(except RDYpol, INTpol, IOBE bits) and NAND Flash core into default state as the warm reset(=reset by RP pin).

This R/W register describes the operation of the OneNAND interface.

Note that all commands should be issued right after INT is turned from ready state to busy state. (i.e. right after 0 is written to INT register.) After any command is issued and the corresponding operation is completed, INT goes back to ready state. (00F0h and 00F3h may be accepted during busy state of some operations. Refer to the rightmost column of the command register table above.)

## 7.18 System Configuration 1 Register (R, R/W): F221h, default=40C0h

15	14	13	12	11	10	9	8	7	6	5	4	3	2	1	0
R/W	R/W		R/W			R/W	R/W	R/W	R/W	R				R	
RM	BRL		BL			ECC	RDY pol	INT pol	IOBE	Reserved(0000)				BW PS	

**RM** (Read Mode): this field specifies the selection between asynchronous read mode and synchronous read mode

RM	Read Mode
0	Asynchronous read(default)
1	Synchronous read

**BRL** (Burst Read Latency): this field specifies the initial access latency in the burst read transfer.

BRL	Latency Cycles
000	8(N/A)
001	9(N/A)
010	10(N/A)
011	3(N/A)
100	4(default, min.)
101	5
110	6
111	7

**BL** (Burst Length): this field specifies the size of burst length during Sync. burst read. Wrap around and linear burst.

BL	Burst Length(Main)	Burst Length(Spare)
000	Continuous(default)	
001	4 words	
010	8 words	
011	16 words	
100	32 words	N/A
101~111	Reserved	

**ECC**: Error Correction Operation,  
0=with correction(default), 1=without correction(by-passed)

**RDYpol**: RDY signal polarity  
0=low for ready, 1=high for ready((default)

**INTpol**: INT pin polarity  
0=low for Interrupt pending , 1=high for Interrupt pending (default)

INTpol	INT bit of Interrupt Status Register	INT Pin output
0	0	1
1	0	0

**IOBE**: I/O buffer enable for INT and RDY signals, INT and RDY outputs are HighZ at power-up, bit 7 and 6 become valid after IOBE is set to 1.  
IOBE can be reset only by Cold reset or by writing 0 to bit 5 of System Configuration 1 register.  
0=disable(default), 1=enable

**BWPS**: boot buffer write protect status,  
0=locked(default)

**7.19 System Configuration 2 Register : F222h**

: N/A

**7.22 Controller Status Register (R): F240h, default=0000h**

15	14	13	12	11	10	9	8	7	6	5	4	3	2	1	0
CB	FC	RB	WB	EB	WRc	Reserv ed(0)	Reserv ed(0)	RSTB	Reserved(000000)						TO (0)

**CB**(Controller Busy) : this bit shows the overall internal status of OneNAND  
0=ready, 1=busy

**FC** (Fault Check): this bit shows whether host loads data from NAND Flash array into locked BootRAM or programs/erases locked block of NAND Flash array or put invalid command into the device.

FC	Fault Check Result
0	No fault
1	Fault

**WRc** (Current Sector/Page Write Result): this bit shows current sector/page Program/Copy Back Program/Erase result of flash memory.

WRc	Current Sector/Page Program/CopyBack. Program/Erase Result
0	Pass
1	Fail

**TO** (Time Out): time out for load/program/copy back program/erase  
0=no time out(fixed)

**RB**(Read Busy) : this bit shows the Load operation status  
0=ready(default), 1=busy

**WB**(Write Busy) : this bit shows the Program operation status  
0=ready(default), 1=busy

**EB**(Erase Busy) : this bit shows the Erase operation status  
0=ready(default), 1=busy

**RSTB**(Reset Busy) : this bit shows the Reset operation status  
0=ready(default), 1=busy

table 2. Controller Status Register output for modes.

Mode	Controller Status Register [15:0]										
	CB	FC	RB	WB	EB	WRc	Reserved(0)	PRp	RSTB	Reserved(0)	TO
Load Ongoing	1	0	1	0	0	0	0	0	0	000000	0
Program Ongoing	1	0	0	1	0	0	0	0	0	000000	0
Erase Ongoing	1	0	0	0	1	0	0	0	0	000000	0
Reset Ongoing	1	0	0	0	0	0	0	0	1	000000	0
Load OK	0	0	0	0	0	0	0	0	0	000000	0
Program OK	0	0	0	0	0	0	0	0	0	000000	0
Erase OK	0	0	0	0	0	0	0	0	0	000000	0
Load Fail <sup>1)</sup>	0	0	0	0	0	0	0	0	0	000000	0
Program Fail	0	0	0	0	0	1	0	0	0	000000	0
Erase Fail	0	0	0	0	0	1	0	0	0	000000	0
Load Reset <sup>2)</sup>	0	0	0	0	0	0	0	0	0	000000	0
Program Reset	0	0	0	0	0	0	0	0	0	000000	0
Erase Reset	0	0	0	0	0	0	0	0	0	000000	0
Program Lock	0	1	0	0	0	0	0	0	0	000000	0
Erase Lock	0	1	0	0	0	0	0	0	0	000000	0
Load Lock(Buffer Lock)	0	1	0	0	0	0	0	0	0	000000	0
OTP Program Fail(Lock)	0	1	0	0	0	0	0	0	0	000000	0
OTP Program Fail	0	0	0	0	0	1	0	0	0	000000	0
Invalid Command	0	1	0	0	0	0	0	0	0	000000	0

**NOTE:** 1. ERm and/or ERs bits in ECC status register at Load Fail case is 10. (2bits error - uncorrectable)

2. ERm and ERs bits in ECC status register at Load Reset case are 00. (No error)

3. OTP Erase does not update the register and the previous value is kept.

**7.23 Interrupt Status Register (R/W): F241h, default=8080h(after Cold reset),8010h(after Warm/Hot reset)**

15	14	13	12	11	10	9	8	7	6	5	4	3	2	1	0	
INT	Reserved(0000000)							RI	WI	EI	RSTI	Reserved(0000)				

Bit Address	Bit Name	Default State		Valid States	Function
		Cold	Warm/Hot		
15	INT(interrupt): the master interrupt bit	1	1	0	Interrupt Off
	- Set to '1' of itself when one or more of RI, WI, EI and RSTI is set to '1', or Unlock(0023h), Lock(002Ah), Lock-tight(002Ch) or OTP access(0075h - 0065h) operation is completed. - Cleared to '0' when by writing '0' to this bit or by reset(Cold/Warm/Hot reset). '0' in this bit means that INT pin is low status. (This INT bit is directly wired to the INT pin on the chip. INT pin goes low upon writing '0' to this bit when INTpol is high and goes high upon writing '0' to this bit when INTpol is low. )			0->1	Interrupt Pending
7	RI(Read Interrupt):	1	0	0	Interrupt Off
	- Set to '1' of itself at the completion of Load Operation (0000h, 0013h, or boot is done.) - Cleared to '0' when by writing '0' to this bit or by reset (Cold/Warm/Hot reset).			0->1	Interrupt Pending
6	WI(Write Interrupt):	0	0	0	Interrupt Off
	- Set to '1' of itself at the completion of Program Operation (0080h, 001Ah, or 001Bh) - Cleared to '0' when by writing '0' to this bit or by reset (Cold/Warm/Hot reset).			0->1	Interrupt Pending
5	EI(Erase Interrupt):	0	0	0	Interrupt Off
	- Set to '1' of itself at the completion of Erase Operation (0094h) - Cleared to '0' when by writing '0' to this bit or by reset (Cold/Warm/Hot reset).			0->1	Interrupt Pending
4	RSTI(Reset Interrupt):	0	1	0	Interrupt Off
	- Set to '1' of itself at the completion of Reset Operation (00F0h, 00F3h, or warm reset is released.) - Cleared to '0' when by writing '0' to this bit.			0->1	Interrupt Pending

**7.24 Start Block Address (R/W): F24Ch, default=0000h**

15	14	13	12	11	10	9	8	7	6	5	4	3	2	1	0
Reserved(0000000)								SBA							

**SBA** (Start Block Address): Start NAND Flash block address to unlock in Write Protection mode, which precedes 'Unlock block command'.

**7.25 End Block Address (R/W): F24Dh, default=0000h**

15	14	13	12	11	10	9	8	7	6	5	4	3	2	1	0
Reserved(0000000)								EBA							

**EBA** (End Block Address): End NAND Flash block address to unlock in Write Protection mode, which precedes 'Unlock block command'. EBA should be equal to or larger than SBA.

Device	Number of Block	SBA/EBA
512Mb	512	[8:0]

## 7.26 NAND Flash Write Protection Status (R): F24Eh, default=0002h

15	14	13	12	11	10	9	8	7	6	5	4	3	2	1	0
Reserved(0000000000000)													US	LS	LTS

**US** (Unlocked Status): '1' value of this bit specifies that there is unlocked block in NAND Flash.

**LS** (Locked Status): '1' value of this bit specifies that there is locked block in NAND Flash.

**LTS** (Lock-tighten Status): '1' value of this bit specifies that 'Locked block(s)' is lock-tighten.

## 7.27 ECC Status Register(R): FF00h, default=0000h

15	14	13	12	11	10	9	8	7	6	5	4	3	2	1	0
ERm3		ERs3		ERm2		ERs2		ERm1		ERs1		ERm0		ERs0	

**ERm** (ECC Error for Main area data) & **ERs** (ECC Error for Spare area data)

ERm0/1/2/3 is for first/second/third/fourth selected sector main of BufferRAM, ERs0/1/2/3 is for first/second/third/fourth selected sector spare of BufferRAM.

ERm and ERs show the number of error in a sector as a result of ECC check at the load operation.

ERm and ERs bits are updated in boot loading operation, too.

ERm, ERs	ECC Status
00	No Error
01	1-bit error(correctable)
10	2-bit error(uncorrectable) <sup>1)</sup>
11	Reserved

**NOTE:**

1. 3bits or more error detection is not supported.

## 7.28 ECC Result of first selected Sector Main area data Register (R): FF01h, default=0000h

15	14	13	12	11	10	9	8	7	6	5	4	3	2	1	0
Reserved(0000)				ECCposWord0								ECCposIO0			

## 7.29 ECC Result of first selected Sector Spare area data Register (R): FF02h, default=0000h

15	14	13	12	11	10	9	8	7	6	5	4	3	2	1	0
Reserved(0000000000)										ECClogSector0			ECCposIO0		

## 7.30 ECC Result of second selected Sector Main area data Register (R): FF03h, default=0000h

15	14	13	12	11	10	9	8	7	6	5	4	3	2	1	0
Reserved(0000)				ECCposWord1								ECCposIO1			

## 7.31 ECC Result of second selected Sector Spare area data Register (R): FF04h, default=0000h

15	14	13	12	11	10	9	8	7	6	5	4	3	2	1	0
Reserved(0000000000)										ECClogSector1			ECCposIO1		

## 7.32 ECC Result of third selected Sector Main area data Register (R): FF05h, default=0000h

15	14	13	12	11	10	9	8	7	6	5	4	3	2	1	0
Reserved(0000)				ECCposWord2								ECCposIO2			

**7.33 ECC Result of third selected Sector Spare area data Register (R): FF06h, default=0000h**

15	14	13	12	11	10	9	8	7	6	5	4	3	2	1	0
Reserved(0000000000)										ECClogSector2		ECCposIO2			

**7.34 ECC Result of fourth selected Sector Main area data Register (R): FF07h, default=0000h**

15	14	13	12	11	10	9	8	7	6	5	4	3	2	1	0
Reserved(0000)				ECCposWord3								ECCposIO3			

**7.35 ECC Result of fourth selected Sector Spare area data Register (R): FF08h, default=0000h**

15	14	13	12	11	10	9	8	7	6	5	4	3	2	1	0
Reserved(0000000000)										ECClogSector3		ECCposIO3			

**NOTE:**

1. ECCposWord: ECC error position address that selects one of Main area data(256words)
2. ECCposIO: ECC error position address which selects one of sixteen DQs (DQ 0~DQ 15).
3. ECClogSector: ECC error position address that selects one of the 2nd word and LSB of the 3rd word of spare area. Refer to the below table.

**ECClogSector Information [5:4]**

ECClogSector	Error Position
00	2nd word
01	3rd word
10, 11	Reserved

## 8 Device Operation

The device supports both a limited command based and a register based interface for performing operations on the device, reading device ID, writing data to buffer etc. The command based interface is active in the boot partition, i.e. commands can only be written with a boot area address. Boot area data is only returned if no command has been issued prior to the read.

### 8.1 Command based operation

The entire address range, except for the boot area, can be used for the data buffer. All commands are written to the boot partition. Writes outside the boot partition are treated as normal writes to the buffers or registers. The command consists of one or more cycles depending on the command. After completion of the command the device starts its execution. Writing incorrect information which include address and data or writing an improper command will terminate the previous command sequence and make the device go to the ready status. The defined valid command sequences are stated in Table3.

**Table 3. Command Sequences**

Command Definition		Cycles	1st cycle	2nd cycle
Read Data from Buffer	Add	1	DP <sup>1)</sup>	
	Data		Data	
Write Data to Buffer	Add	1	DP	
	Data		Data	
Reset OneNAND	Add	1	BP <sup>2)</sup>	
	Data		00F0h	
Load Data into Buffer <sup>3)</sup>	Add	2	BP	BP
	Data		00E0h	0000h <sup>4)</sup>
Read Identification Data <sup>6)</sup>	Add	2	BP	XXXXh <sup>5)</sup>
	Data		0090h	Data

**NOTE:**

- 1) DP(Data Partition) : DataRAM Area
- 2) BP(Boot Partition) : BootRAM Area [0000h ~ 01FFh, 8000h ~ 800Fh]. It is locked after power-up.
- 3) Load Data into Buffer operation is available within a block(128KB)
- 4) Load 2KB unit into DataRAM0. Current Start address(FPA) is automatically incremented by 2KB unit after the load.
- 5) 0000h -> Data is Manufacturer ID  
0001h -> Data is Device ID
- 6) WE toggling can terminate 'Read Identification Data' operation.

#### 8.1.1 Read Data from Buffer

Buffer can be read by addressing a read to a wanted buffer area

#### 8.1.2 Write Data to Buffer

Buffer can be written by addressing a write to a wanted buffer area

#### 8.1.3 Reset OneNAND

Reset command is given by writing 00F0h to the boot partition address. Reset will return all default values into the device.

#### 8.1.4 Load Data into Buffer

Load Data into Buffer command is a two-cycle command. Two sequential designated command activates this operation. Sequentially writing 00E0h and 0000h to the boot partition [0000h~01FFh, 8000h~800Fh] will load one page to DataRAM0. This operation refers to FBA and FPA. FSA, BSA, and BSC are not considered. At the end of this operation, FPA will be automatically increased by 1. So continuous issue of this command will sequentially load data in next page to DataRAM0. This page address increment is restricted within a block. The default value of FBA and FPA is 0. Therefore, initial issue of this command after power on will load the first page of memory, which is usually boot code.

#### 8.1.5 Read Identification Data

Read Identification Data command consists of two cycles. It gives out the devices identification data according to the given address. The first cycle is 0090h to the boot partition address and second cycle is read from the addresses specified in Table5.

Table 4. Identification data description

Address	Data Out	
0000h	Manufacturer ID	00ECh
0001h	Device ID	refer to table 1

Device Bus Operations

Operation	$\overline{CE}$	$\overline{OE}$	$\overline{WE}$	ADD0~15	DQ0~15	$\overline{RP}$	CLK	$\overline{AVD}$
Standby	H	X	X	X	High-Z	H	X	X
Warm Reset	X	X	X	X	High-Z	L	X	X
Asynchronous Write	L	H	L	Add. In	Data In	H	L	
Asynchronous Read	L	L	H	Add. In	Data Out	H	L	
Load Initial Burst Address	L	H	H	Add. In	X	H		
Burst Read	L	L	H	X	Burst Data Out	H		X
Terminate Burst Read Cycle	H	X	H	X	High-Z	H	X	X
Terminate Burst Read Cycle via $\overline{RP}$	X	X	X	X	High-Z	L	X	X
Terminate Current Burst Read Cycle and Start New Burst Read Cycle		H	H	Add. In	High-Z	H		

Note : L=V<sub>IL</sub> (Low), H=V<sub>IH</sub> (High), X=Don't Care.

**Reset Mode**

**Cold Reset**

At system power-up, the voltage detector in the device detects the rising edge of Vcc and releases internal power-up reset signal which triggers bootcode loading. Bootcode loading means that the boot loader in the device copies designated sized data(1KB) from the beginning of memory to the BootRAM.

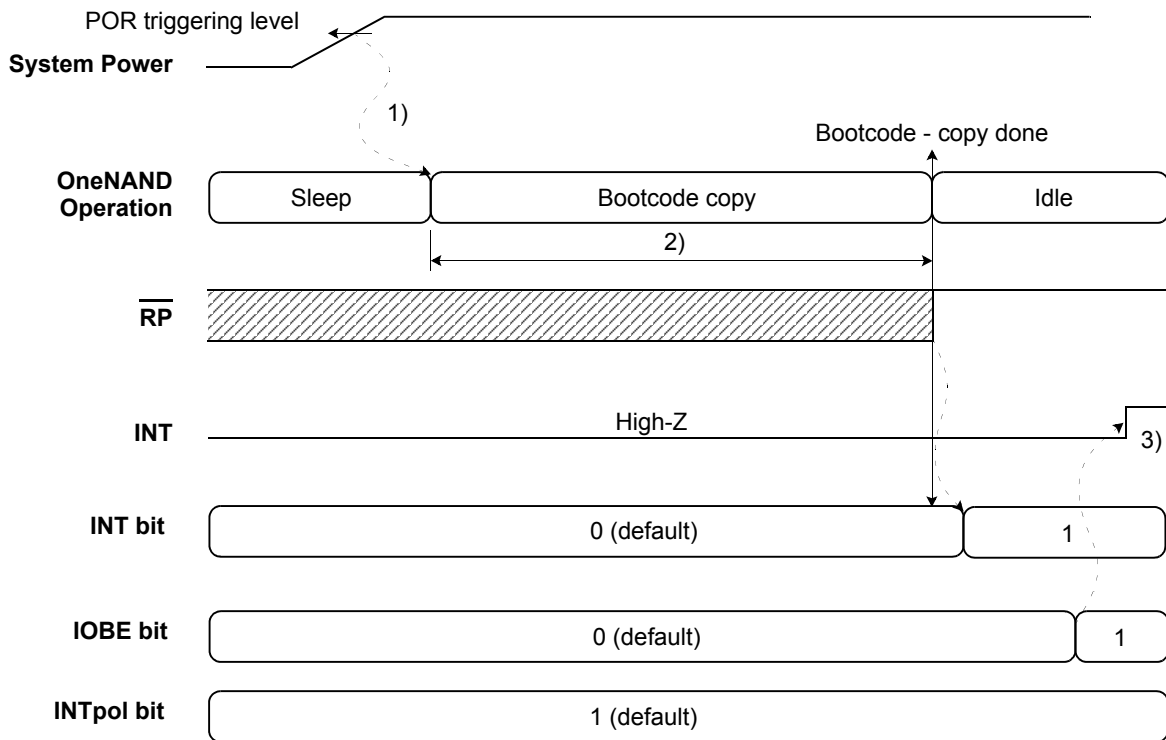

- Note: 1) Bootcode copy operation starts 400us later than POR activation.  
 The system power should reach Vcc after POR triggering level(typ. 1.5V) within 400us for valid boot code data.  
 2) 1K bytes Bootcode copy takes 70us(estimated) from sector0 and sector1/page0/block0 of NAND Flash array to BootRAM.  
 Host can read Bootcode in BootRAM(1K bytes) after Bootcode copy completion.  
 3) INT register goes 'Low' to 'High' on the condition of 'Bootcode-copy done' and  $\overline{RP}$  rising edge.  
 If  $\overline{RP}$  goes 'Low' to 'High' before 'Bootcode-copy done', INT register goes to 'Low' to 'High' as soon as 'Bootcode-copy done'

**Figure 5. Cold Reset Timings**

**Warm Reset**

Warm reset means that the host resets the device by  $\overline{RP}$  pin, and then the device logic stops all current operation and executes internal reset operation (Note 1) synchronized with the falling edge of  $\overline{RP}$  and resets current NAND Flash core operation synchronized with the rising edge of  $\overline{RP}$ . The device logic will not be reset in case  $\overline{RP}$  pulses shorter than 200ns, but the device guarantees the logic reset operation in case  $\overline{RP}$  pulse is longer than 200ns. NAND Flash core reset will abort current NAND Flash Core operation. The contents of memory cells being altered are no longer valid as the data will be partially programmed or erased. Warm reset has no effect on contents of BootRAM and DataRAM.

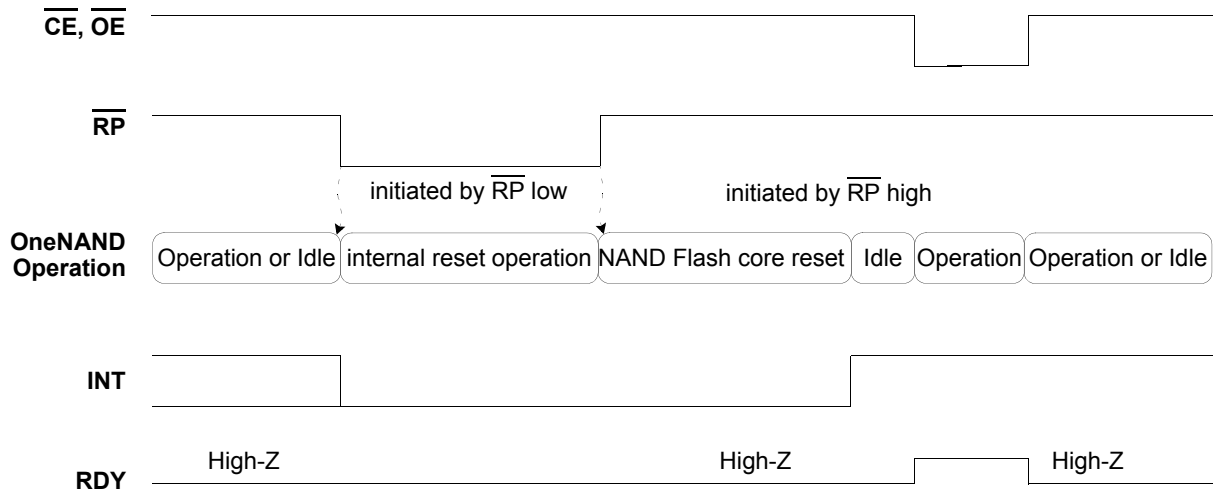

**Figure 6. Warm Reset Timings**

**Hot Reset**

Hot reset means that the host resets the device by reset command(Note 2), and then the device logic stops all current operation and executes internal reset operation(Note 1), and resets current NAND Flash core operation. Hot reset has no effect on contents of BootRAM and DataRAM.

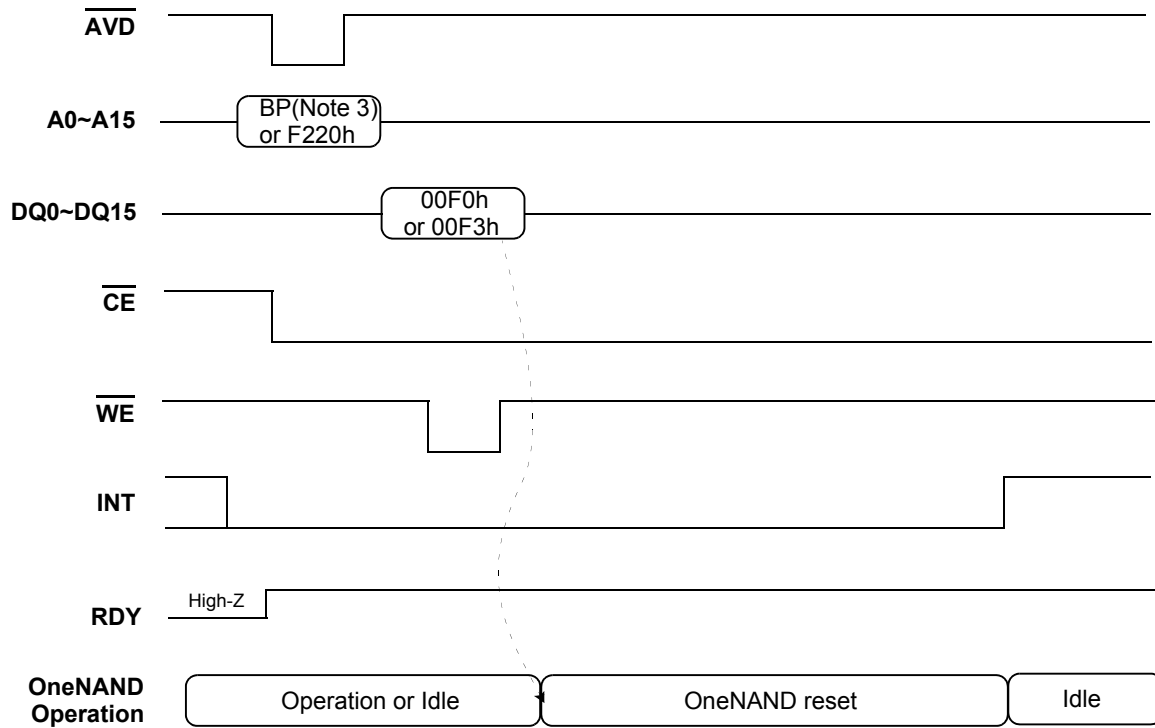

**Figure 7. Hot Reset Timings**

**NOTE:**

1. Internal reset operation means that the device initializes internal registers and makes output signals go to default status and bufferRAM data are kept unchanged after Warm/Hot reset operations.
2. Reset command : Command based reset or Register based reset
3. BP(Boot Partition) : BootRAM area[0000h~01FFh, 8000h~800Fh]

**NAND Flash Core Reset**

Host can reset NAND Flash Core operation by NAND Flash Core reset command. NAND Flash Core Reset will abort the current NAND Flash core operation. During a NAND Flash Core Reset, the content of memory cells being altered is no longer valid as the data will be partially programmed or erased. NAND Flash Core Reset has an effect on neither contents of BootRAM and DataRAM nor register values.

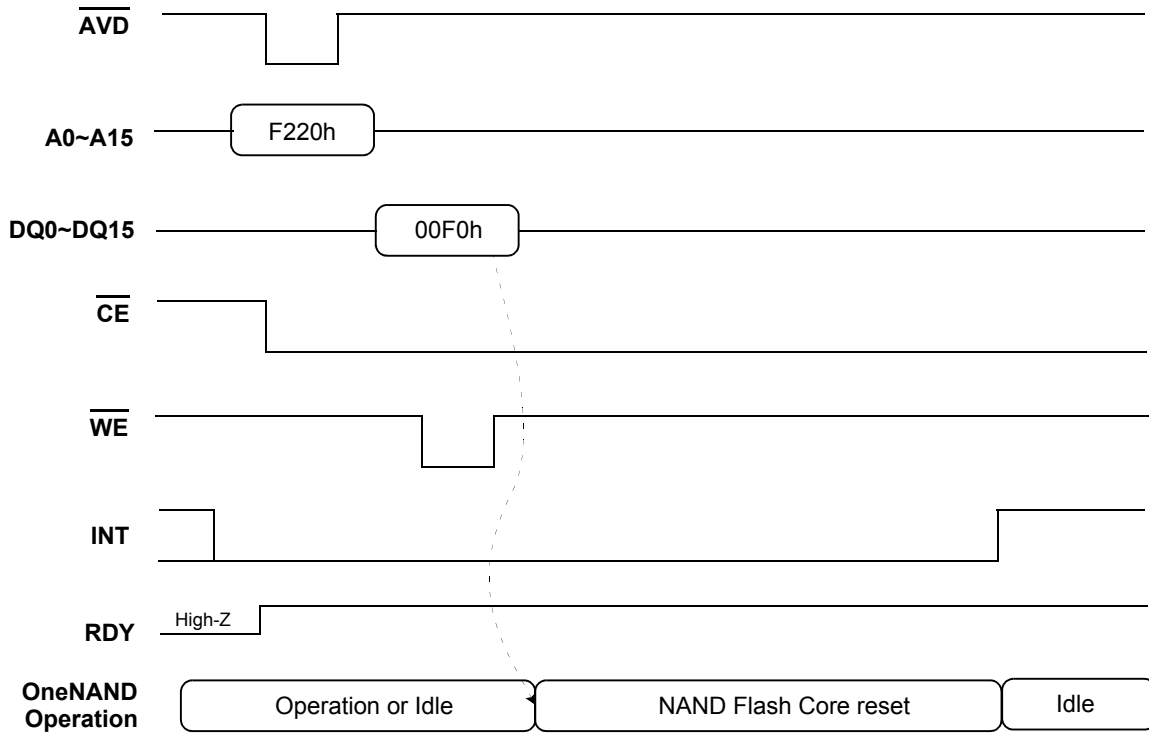

**Figure 8. NAND Flash Core Reset Timings**

Table 7. Internal Register reset

	Internal Registers	Default	Cold Reset	Warn Reset (RP)	Hot Reset (00F3h)	Hot Reset (BP-F0)	NAND Flash Reset(00F0h)
F000h	Manufacturer ID Register (R)	00ECh	N/A	N/A	N/A	N/A	N/A
F001h	Device ID Register (R)	Note3	N/A	N/A	N/A	N/A	N/A
F002h	Version ID Register (rR): 54MHz	001Eh	N/A	N/A	N/A	N/A	N/A
F003h	Data Buffer size Register (R)	0800h	N/A	N/A	N/A	N/A	N/A
F004h	Boot Buffer size Register (R)	0200h	N/A	N/A	N/A	N/A	N/A
F005h	Amount of Buffers Register (R)	0201h	N/A	N/A	N/A	N/A	N/A
F006h	Technology Register (R)	0000h	N/A	N/A	N/A	N/A	N/A
F100h	Start Address1 Register (R/W): DFS, FBA	0000h	0000h	0000h	0000h	0000h	N/A
F101h	Start Address2 Register (R/W): DBS	0000h	0000h	0000h	0000h	0000h	N/A
F102h	Start Address3 Register (R/W): FCBA	0000h	0000h	0000h	0000h	0000h	N/A
F103h	Start Address4 Register (R/W): FCPA, FCSA	0000h	0000h	0000h	0000h	0000h	N/A
F107h	Start Address5 Register (R/W): FPA, FSA	0000h	0000h	0000h	0000h	0000h	N/A
F200h	Start Buffer Register (R/W): BSA, BSC	0000h	0000h	0000h	0000h	0000h	N/A
F220h	Command Register (R/W)	0000h	0000h	0000h	0000h	0000h	N/A
F221h	System Configuration 1 Register (R/W)	40C0h	40C0h	O (Note1)	O (Note1)		N/A
F240h	Controller Status Register (R)	0000h	0000h	0000h	0000h	0000h	N/A
F241h	Interrupt Status Register (R/W)	-	8080h	8010h	8010h	8010h	N/A
F24Ch	Start Block Address (R/W)	0000h	0000h	0000h	N/A	N/A	N/A
F24Dh	End Block Address (R/W)	0000h	0000h	0000h	N/A	N/A	N/A
F24Eh	NAND Flash Write Protection Status (R)	0002h	0002h	0002h	N/A	N/A	N/A
FF00h	ECC Status Register (R) (Note2)	0000h	0000h	0000h	0000h	0000h	N/A
FF01h	ECC Result of Sector 0 Main area data Register(R)	0000h	0000h	0000h	0000h	0000h	N/A
FF02h	ECC Result of Sector 0 Spare area data Register (R)	0000h	0000h	0000h	0000h	0000h	N/A
FF03h	ECC Result of Sector 1 Main area data Register(R)	0000h	0000h	0000h	0000h	0000h	N/A
FF04h	ECC Result of Sector 1 Spare area data Register (R)	0000h	0000h	0000h	0000h	0000h	N/A
FF05h	ECC Result of Sector 2 Main area data Register(R)	0000h	0000h	0000h	0000h	0000h	N/A
FF06h	ECC Result of Sector 2 Spare area data Register (R)	0000h	0000h	0000h	0000h	0000h	N/A
FF07h	ECC Result of Sector 3 Main area data Register(R)	0000h	0000h	0000h	0000h	0000h	N/A
FF08h	ECC Result of Sector 3 Spare area data Register (R)	0000h	0000h	0000h	0000h	0000h	N/A

**NOTE:** 1) RDYpol, INTpol, and IOBE are reset by Cold reset. The other bits are reset by Cold/Warm/Hot reset.

2) ECC Status Register & ECC Result Registers are reset when any command is issued.

3) Refer to table 1

## Write Protection

### Write Protection for BootRAM

At system power-up, the voltage detector in the device detects the rising edge of Vcc and releases the internal power-up reset signal which triggers bootcode loading. And the designated size data(1KB) is copied from the beginning of the memory to the BootRAM. After the bootcode loading is completed, the BootRAM is always locked to protect the significant boot code from the accidental write.

### Write Protection for NAND Flash array

#### Write Protection Modes

The device offers both hardware and software write protection features for NAND Flash array. The software write protection feature is used by writing Lock command or Lock-tight command to command register;The 002Ah or 002Ch command is written into F220h register. And the hardware write protection feature is used by executing cold or warm reset. The default state is locked, and all NAND Flash array goes to locked state after cold or warm reset.

#### Write Protection Commands

The instant secured block protects code and data by allowing blocks to be locked or lock-tighten. The write protection scheme offers two levels of protection. The first allows software-only control of write protection(useful for frequently changed data blocks), while the second requires hardware interaction before locking can be changed(protects infrequently changed code blocks).

The followings summarize the locking functionality

- > All blocks power-up in a locked state. Unlock commands can unlock these blocks.
- >The lock-tight command makes locked block(s) lock-tighten block(s). And lock-tight state can be returned to lock state only when cold or warm reset is asserted.
- > Lock-tighten blocks offer the user an additional level of write protection beyond that of a regular locked block. Lock-tighten block can't have it's state changed by software, it can be changed by warm reset or cold reset.
- > Unlock start and end block address are reflected immediately to the device only when the unlock command is issued, and NAND Flash write protection status register is also updated at that time.
- > Unlocked blocks can be programmed or erased.
- > Only one consecutive area can be released to unlock state from lock state, i.e unlocking multi area is not available.
- > Partial block lock (a range) is not available, i.e lock operation is only available for all blocks.

#### Write Protection Status

The device current Write Protection status can be read in NAND Flash Write Protection Status Register(F24Eh). There are three bits - US, LS, LTS -, which are not cleared by hot reset. These Write Protection status registers are updated when Write Protection command is entered.

The followings summarize locking status.

example1)

In default, [2:0] values are 010.

- > If host executes unlock block operation, then [2:0] values turn to 110.
- > If host executes lock-tight block operation, then [2:0] values turn to 101.

example2)

If host executes lock block operation, then [2:0] values turn to 010.

- > If host executes lock-tight block operation, then [2:0] values turn to 001.
- > If cold or warm reset is entered, then [2:0] values turn to 010.

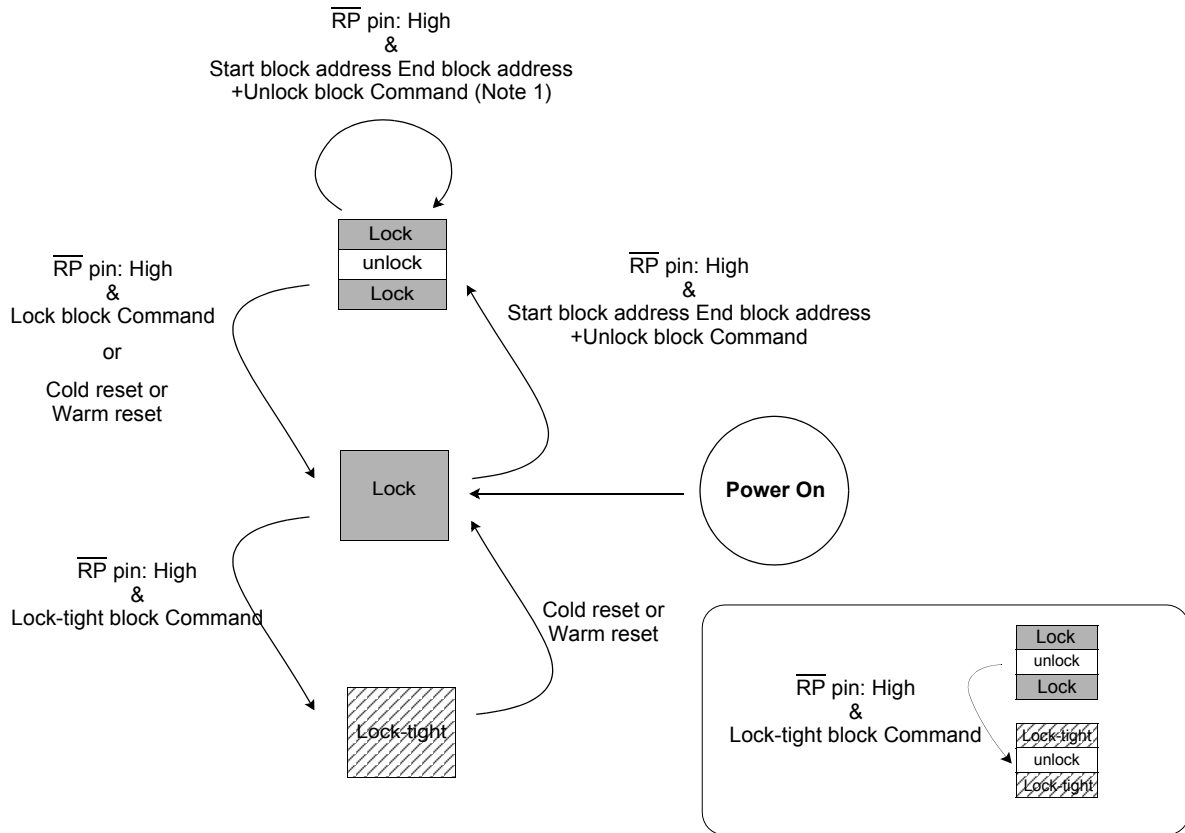

**NOTE:**

1. Unlock range(from Start block address to End block address) can be modified by unlock command sequence(Start block address+End block address).

**Figure 9. State diagram of NAND Flash Write Protection**

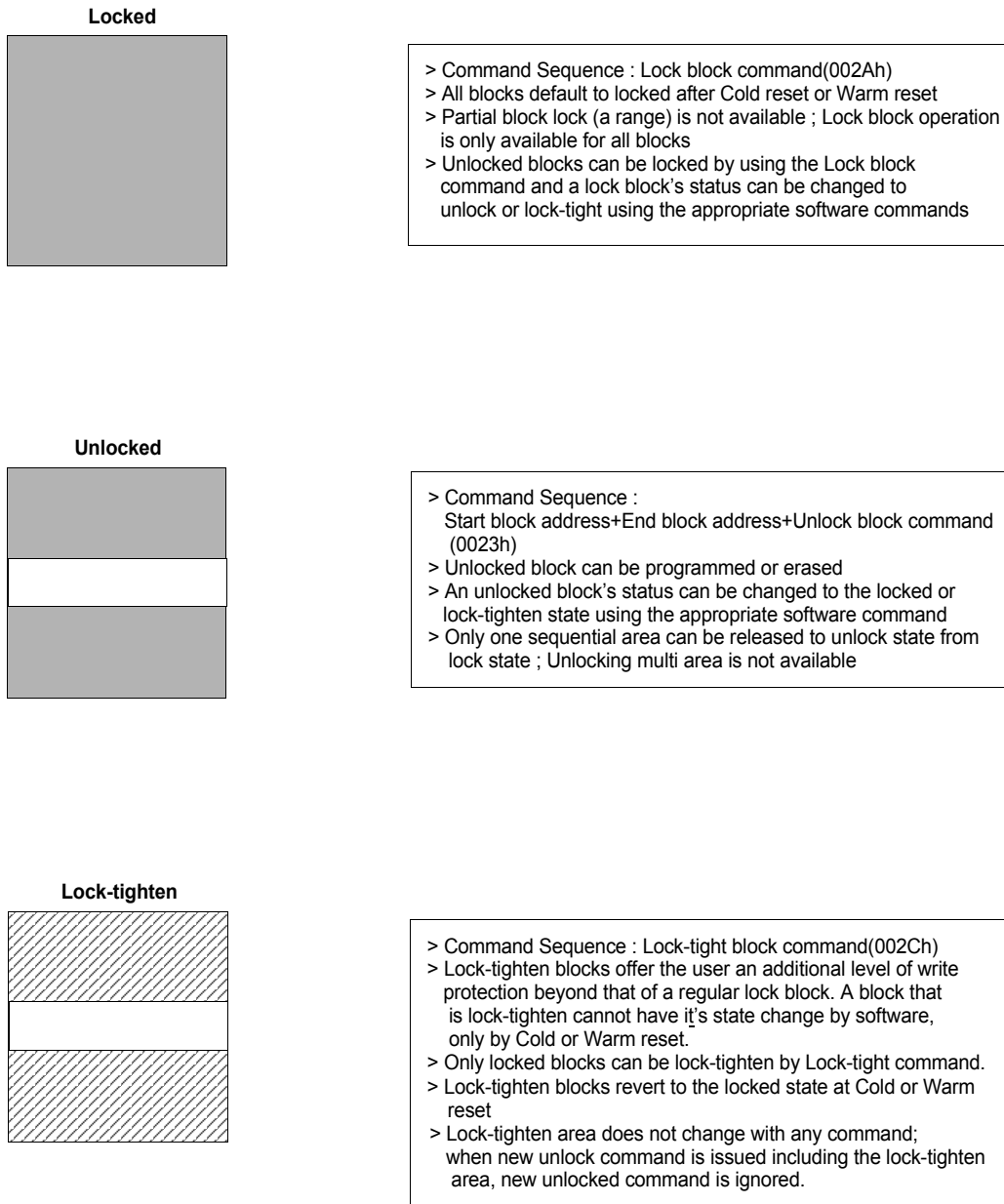
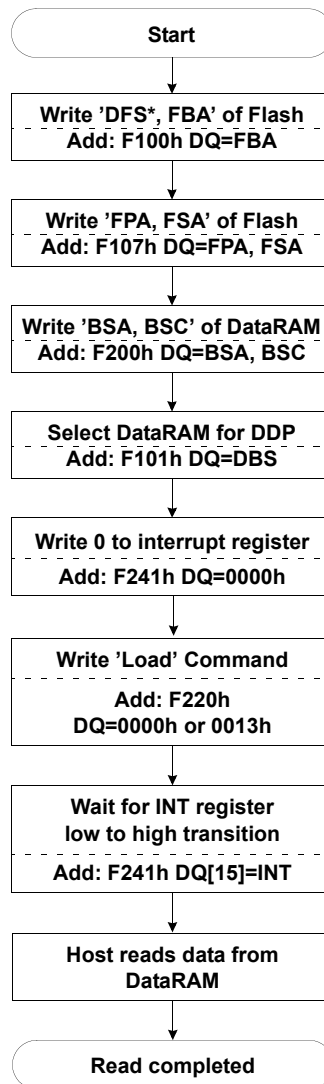

Figure 10. Operations of NAND Flash Write Protection

## Load Operation

The load operation is initiated by setting up the start address from which the data is to be loaded. The load command is issued in order to initiate the load. The device transfers the data from NAND Flash array into the BufferRAM. The ECC is checked and any detected and corrected error is reported in the status response as well as any unrecoverable error. When the BufferRAM has been filled an interrupt is issued to the host in order to read the contents of the BufferRAM. The read from the BufferRAM consist of asynchronous read mode or synchronous read mode. The status information related to the BufferRAM fill operation can be checked by the host if required.

The device provides dual data buffer memory architecture. The device is capable of data-read operation from one data buffer and data-load operation to the other data buffer simultaneously. Refer to the information for more details in "Read while Load operation".



\* DBS, DFS is for DDP

Figure 11. Load operation flow-chart

**Read Operation**

The device has two read configurations ; Asynchronous read and Synchronous burst read. The initial state machine makes the device to be automatically entered into asynchronous read mode to prevent the memory content from spurious altering upon device power up or after a hardware reset. No commands are required to retrieve data in asynchronous mode. The synchronous mode will be enabled by setting RM bit of System configuration1 register to Synchronous read mode.

**Asynchronous Read Mode (RM = 0)**

For the asynchronous read mode a valid address should be asserted on ADD0-ADD15, while driving  $\overline{AVD}$  and  $\overline{CE}$  to  $V_{IL}$ .  $\overline{WE}$  should remain at  $V_{IH}$ . The data will appear on ADD15-ADD0. Address access time ( $t_{AA}$ ) is equal to the delay from valid addresses to valid output data. The chip enable access time( $t_{CE}$ ) is the delay from the falling edge of  $\overline{CE}$  to valid data at the outputs. The output enable access time( $t_{OE}$ ) is the delay from the falling edge of  $\overline{OE}$  to valid data at the output.

**Synchronous (Burst) Read Mode (RM = 1)**

The device is capable of continuous linear burst operation and linear burst operation of a preset length. For the burst mode, the host should determine how many clock cycles are desired for the initial word( $t_{IA}$ ) of each burst access using BRL bit of System configuration 1 register. The registers also can be read during burst read mode by using  $\overline{AVD}$  signal with a address. To initiate the synchronous read again, a new address during  $\overline{CE}$  low toggle is needed after the host has completed status reads or the device has completed the program or erase operation.

**Continuous Linear Burst Read**

The initial word is output  $t_{IA}$  after the rising edge of the first CLK cycle. Subsequent words are output  $t_{BA}$  after the rising edge of each successive clock cycle, which automatically increments the internal address counter. The RDY output indicates this condition to the system by pulsing low. The device will continue to output sequential burst data, wrapping around after it reaches the designated location(See Figure 12 for address map information) until the system asserts  $\overline{CE}$  high,  $\overline{RP}$  low or  $\overline{AVD}$  low in conjunction with a new address. The cold/warm/hot reset or asserting  $\overline{CE}$  high or  $\overline{WE}$  low pulse terminate the burst read operation.

**If the device is accessed synchronously while it is set to asynchronous read mode, it is possible to read out the first data without problems.**

Division	Add.map(word order)	
BootM(0.5Kw)	0000h~01FFh	Buffer0
BufM 0(1Kw)	0200h~05FFh	
BufM 1(1Kw)	0600h~09FFh	Buffer1
Reserved Main	0A00h~7FFFh	N/A Reg.
BootS(16w)	8000H~800Fh	Buffer0
BufS 0(32w)	8010h~802Fh	
BufS 1(32w)	8030h~804Fh	Buffer1
Reserved Spare	8050h~8FFFh	N/A Reg.
Reserved Reg.	9000h~EFFFh	
Register(4Kw)	F000h~FFFFh	Reg.

\* Reserved area is not available on Synchronous read

**Figure 12. The boundary of synchronous read**

### 4-, 8-,16-, 32- Word Linear Burst Read

As well as the Continuous Linear Burst Mode, there are four(4 & 8 & 16 & 32 word) (Note1) linear wrap-around mode, in which a fixed number of words are read from consecutive addresses. When the last word in the burst mode is reached, assert /CE and /OE high to terminate the operation. In these modes, the start address for burst read can be any address of address map.

(Note 1) 32 word linear burst read isn't available on spare area BufferRAM

**Table 6. Burst Address Sequences**

	Start Addr.	Burst Address Sequence(Decimal)				
		Continuous Burst	4-word Burst	8-word Burst	16-word Burst	32-word Burst
Wrap around	0	0-1-2-3-4-5-6...	0-1-2-3-0...	0-1-2-3-4-5-6-7-0...	0-1-2-3-4-....-13-14-15-0...	0-1-2-3-4-....-29-30-31-0...
	1	1-2-3-4-5-6-7...	1-2-3-0-1...	1-2-3-4-5-6-7-0-1...	1-2-3-4-5-....-14-15-0-1...	1-2-3-4-5-....-30-31-0-1...
	2	2-3-4-5-6-7-8...	2-3-0-1-2...	2-3-4-5-6-7-0-1-2...	2-3-4-5-6-....-15-0-1-2...	2-3-4-5-6-....-31-0-1-2...
	.	.	.	.	.	.

### Programmable Burst Read Latency

The programmable burst read latency feature indicates to the device the number of additional clock cycles that must elapse after  $\overline{AVD}$  is driven active before data will be available. Upon power up, the number of total initial access cycles defaults to four clocks. The number of total initial access cycles is programmable from four to seven cycles.

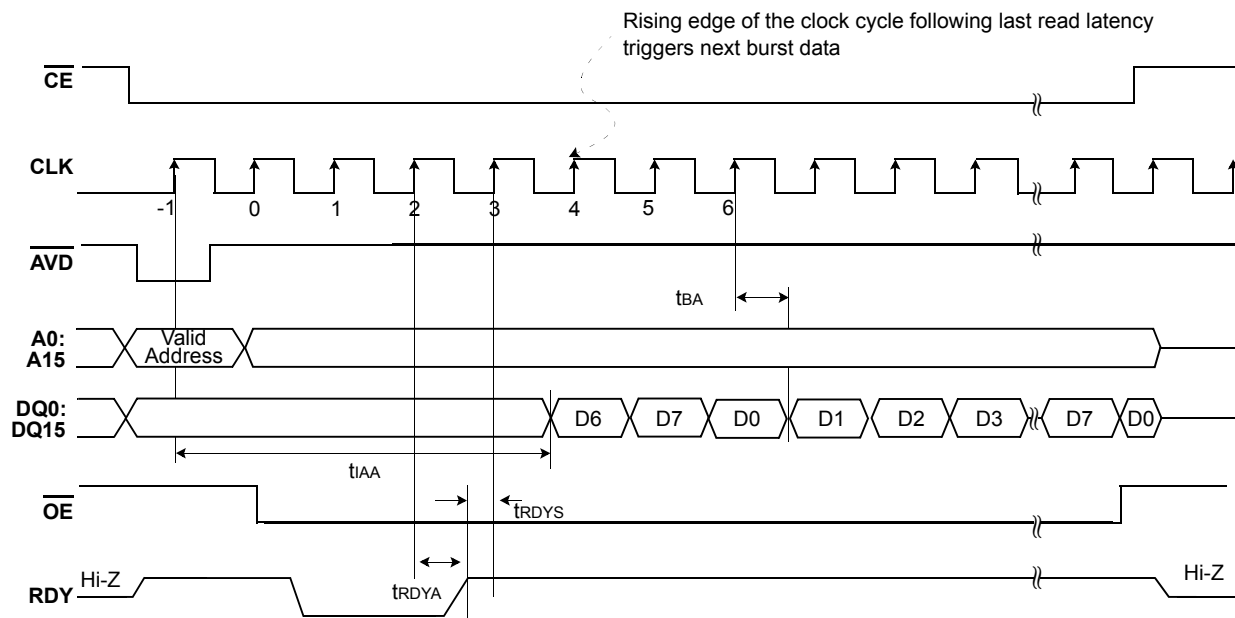

**Figure 13. Example of 4clock Burst Read Latency**

### Handshaking

The handshaking feature allows the host system to simply monitor the RDY signal from the device to determine when the initial word of burst data is ready to be read. To set the number of initial cycle for optimal burst mode, the host should use the programmable burst read latency configuration.(See "System Configuration1 Register" for details.) The rising edge of RDY which is derived from 1 clock ahead of data fetch clock indicates the initial word of valid burst data.

### Output Disable Mode

When the  $\overline{CE}$  or  $\overline{OE}$  input is at  $V_{IH}$ , output from the device is disabled. The outputs are placed in the high impedance state.

**Program Operation**

The device can be programmed in data unit. Programming is writing 0's into the memory array by executing the internal program routine. In order to perform the Internal Program Routine, command sequence is necessary. First, host sets the address of the BufferRAM and the memory location and loads the data to be programmed into the BufferRAM. Second, program command initiates the internal program routine. During the execution of the Routine, the host is not required to provide further controls or timings. During the Internal Program Routine, commands except reset command written to the device will be ignored.

Note that a reset during a program operation will cause data corruption at the corresponding location.

The device provides dual data buffer memory architecture. The device is capable of data-write operation from host to one of data buffers during program operation from another data buffer to Flash simultaneously. Refer to the information for more details in "Read while Load operation".

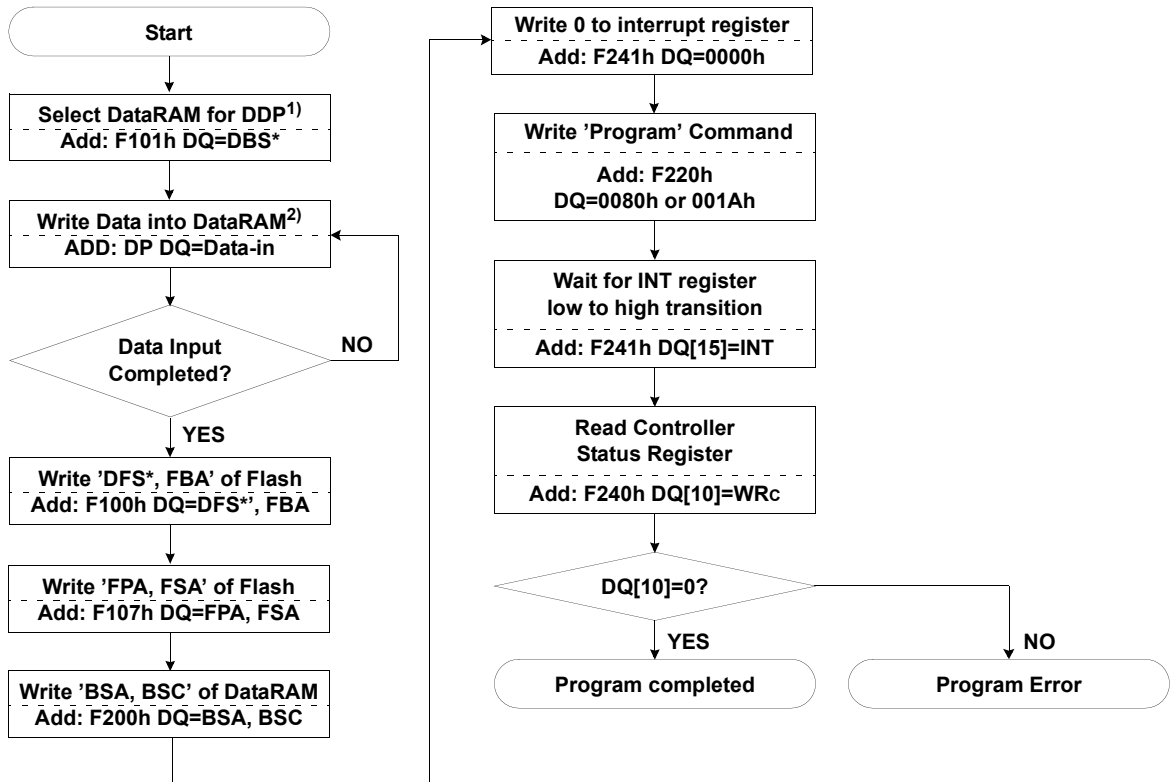

\* DBS, DFS is for DDP

\* : If program operation results in an error, map out the block including the page in error and copy the target data to another block.

Note 1) This must happen before data input

2) Data input could be done anywhere between "Start" and "Write Program Command".

Figure 14. Program operation flow-chart

**Addressing for program operation**

Within a block, the pages must be programmed consecutively from the LSB (least significant bit) page of the block to MSB (most significant bit) pages of the block. Random page address programming is prohibited.

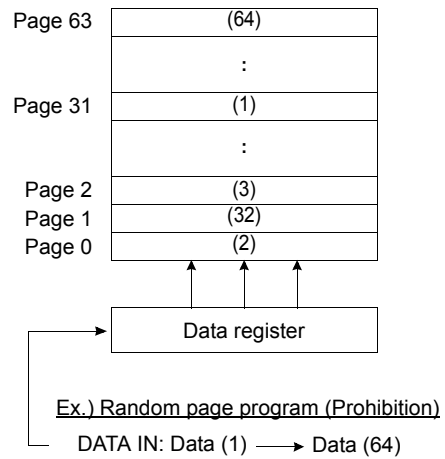
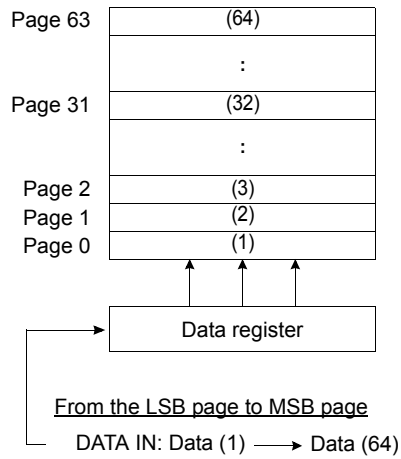

**Copy-back Program Operation**

The copy-back program is configured to quickly and efficiently rewrite data stored in one page by sector unit(1/2/3/4 sector) without utilizing an external memory. Since the time-consuming cycles of serial access and re-loading cycles are removed, the system performance is improved. The benefit is especially obvious when a portion of a block is updated and the rest of the block also need to be copied to the newly assigned free block. The operation for performing a copy-back program is a sequential execution of page-read without serial access and copying-program with the address of destination page.

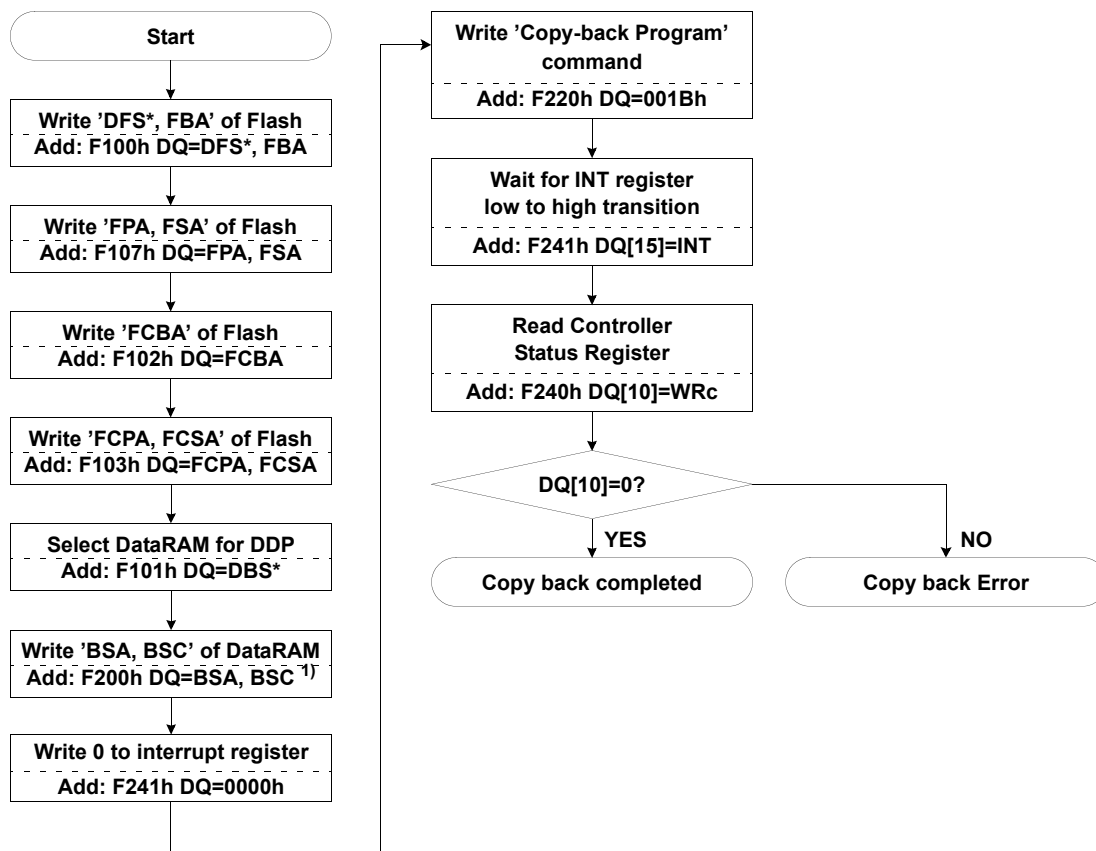

\* : If program operation results in an error, map out the block including the page in error and copy the target data to another block.

\* DBS, DFS is for DDP

Note 1) Selected DataRAM by BSA & BSC is used for Copy back operation, so previous data is overwritten.

Figure 15. Copy back program operation flow-chart

Copy-Back Program Operation with Random Data Input

The Copy-Back Program Operation with Random Data Input in OneNAND consists of 2 phase, Load data into DataRAM, Modify data and program into designated page. Data from the source page is saved in one of the on-chip DataRAM buffers and modified by the host, then programmed into the destination page.

As shown in the flow chart, data modification is possible upon completion of load operation. ECC is also available at the end of load operation. Therefore, using hardware ECC of OneNAND, accumulation of 1 bit error can be avoided.

Copy-Back Program Operation with Random Data Input will be effectively utilized at modifying certain bit, byte, word, or sector of source page to destination page while it is being copied.

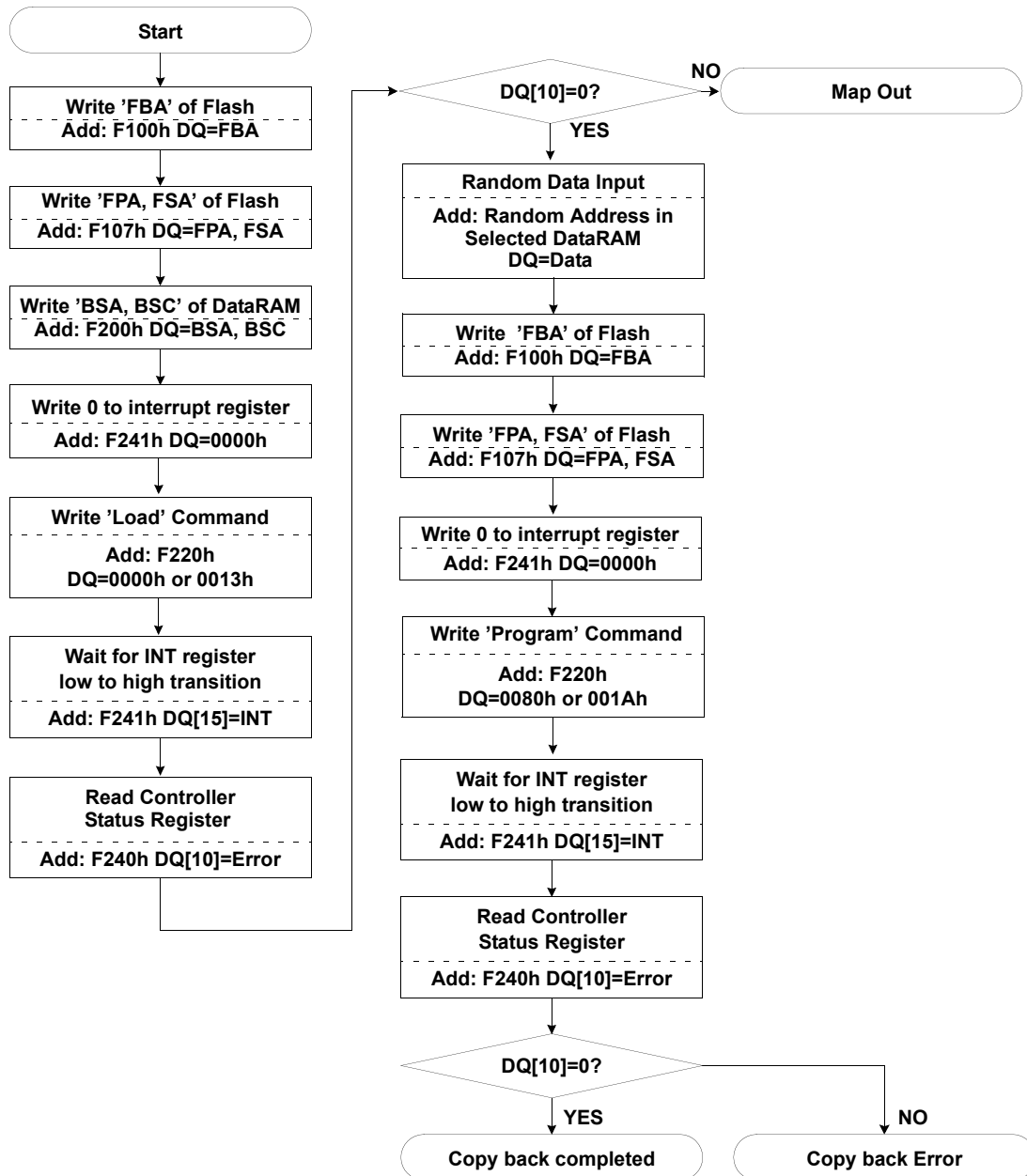

Figure 16. Copy-Back Program Operation with Random Data Input Flow Chart

Erase Operation

The device can be erased in block unit. To erase a block is to write 1's into the desired memory block by executing the Internal Erase Routine. In order to perform the Internal Erase Routine, command sequence is necessary. First, host sets the block address of the memory location. Second, erase command initiates the internal erase routine. During the execution of the Routine, the host is not required to provide further controls or timings. During the Internal erase routine, commands except reset command written to the device will be ignored.

Note that a reset during a erase operation will cause data corruption at the corresponding location.

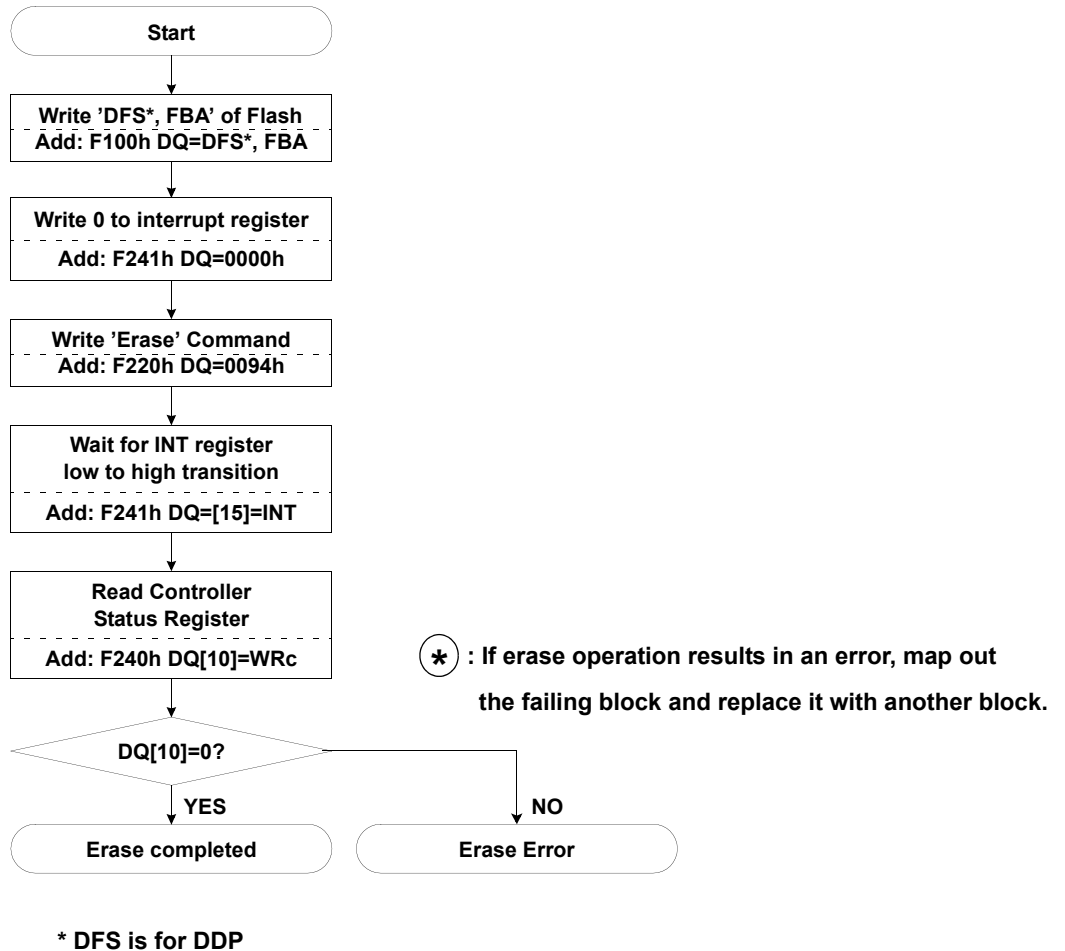

Figure 17. Erase operation flow-chart

**OTP Operation**

The device supports one block sized OTP area, which can be read and programmed with the same sequence as normal operation. But this OTP block could not be erased. This block is separated from NAND Flash Array, so it could be accessed by OTP Access command instead of FBA. If user wants to exit from OTP access mode, Cold, Warm and Hot Reset operation should be done. OTP area is one block size(128KB, 64pages) and is divided by two areas. The first area from page 0 to page 9, total 10pages, is assigned for user and the second area from page 10 to page 63, total 54pages, are occupied for the device manufacturer. The manufacturer area is programmed prior to shipping, so this area could not be used by user. This block is fully guaranteed to be a valid block.

**OTP Block Page Allocation Information**

Area	Page	Use
User	0 ~ 9 (10 pages)	Designated as user area
Manufacturer	10 ~ 63 (54 pages)	Used by the device manufacturer

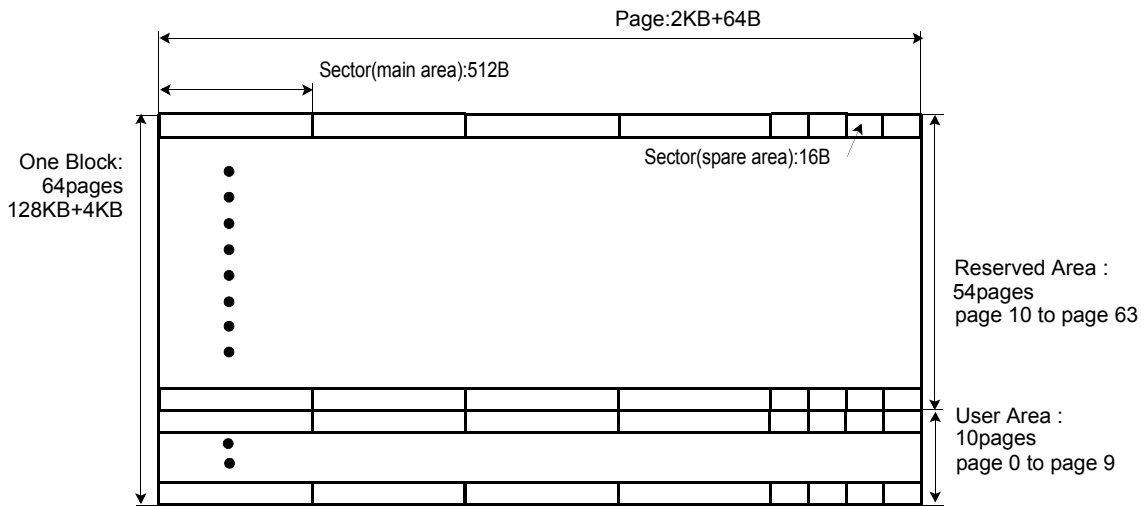

**Figure 18. OTP area structure and assignment**

**OTP Load(OTP Access+Load NAND)**

OTP area is separated from NAND Flash Array, so it is accessed by OTP Access command instead of FBA. The content of OTP could be loaded with the same sequence as normal load operation after being accessed by the command. If user wants to exit from OTP access mode, Cold, Warm, Hot or NAND Flash Core Reset operation should be done.

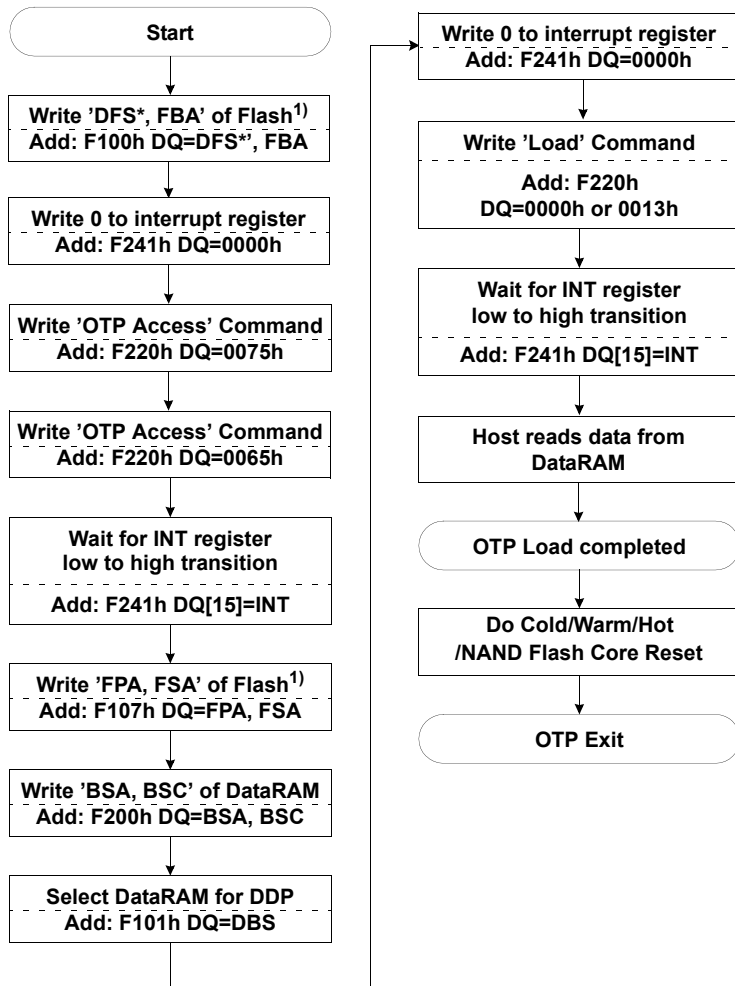

\* DBS, DFS is for DDP

Note 1) FBA(NAND Flash Block Address) could be omitted or any address.

Figure 19. OTP load operation flow-chart

OTP Programming(OTP Access+Program NAND)

OTP area could be programmed with the same sequence as normal program operation after being accessed by the command. But in case of OTP area program, OTP area is not a real OTP area but can be programmed more than once. And 2 command sequence is used to avoid the accidental write. To avoid the accidental write, FBA should point the unlocked area address among NAND Flash Array address map even though OTP area is separated from NAND Flash Array.

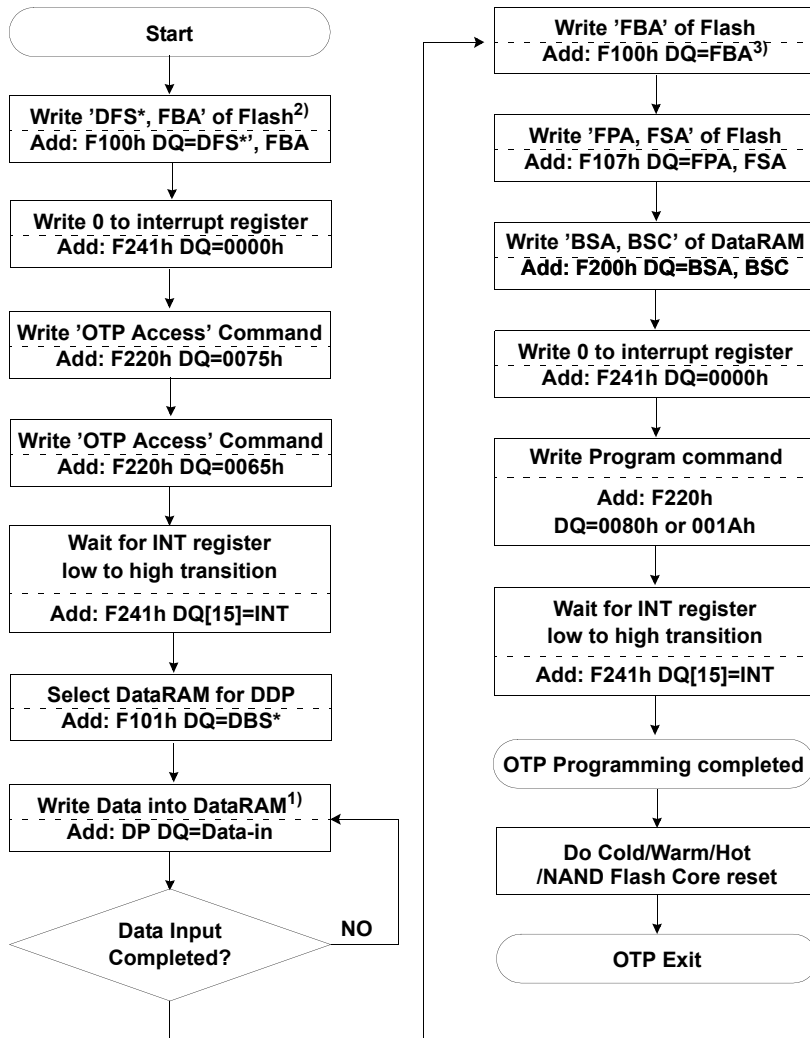

\* DBS, DFS is for DDP

- Note 1) FBA(NAND Flash Block Address) could be any address.
- 2) Data input could be done anywhere between "Start" and "Write Program Command".
- 3) FBA should point the unlocked area address among NADND Flash Array address map.

Figure 20. OTP program operation flow-chart

**Read While Load**

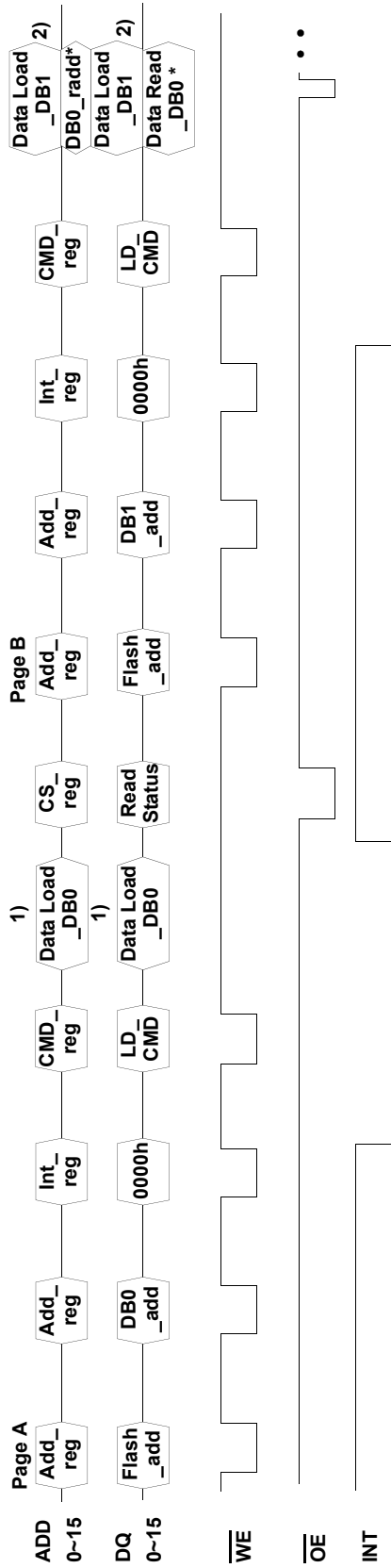

\* DBS should be set before accessing DataRAM for DDP

- Int\_reg : Interrupt Register Address
- Add\_reg : Address Register Address
- Flash\_add : Flash Address to be loaded
- DBn\_add : DataRAM Address to be loaded
- CMD\_reg : Command Register Address
- LD\_CMD : Load Command
- Data\_Load\_Dbn : Load Data from NAND Flash Array to DataRAMn
- CS\_reg : Controller Status Register Address
- Data\_Read\_Dbn : Read Data from DBn
- DBn\_radd : DataRAM Address to be read

The device provides dual data buffer memory architecture. The device is capable of data-read operation from one data buffer and load operation to another data buffer simultaneously. This is so called the Read while Load operation with dual data buffer architecture, this feature provides the capability of executing reading data from one of data buffers during load operation from Flash to the other buffer simultaneously. Refer to the information for more details in "Load operation" before performing read while load operation. Simultaneous load and read operation to same data buffer is prohibited.

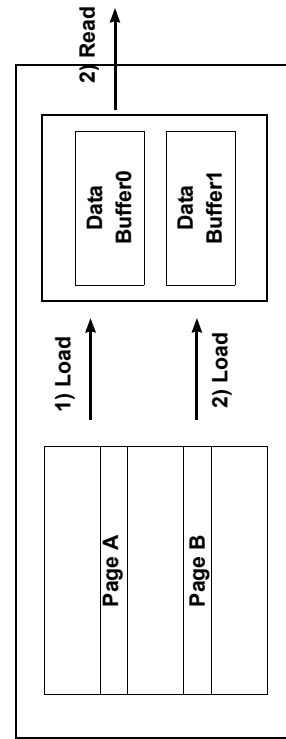

Write While Program

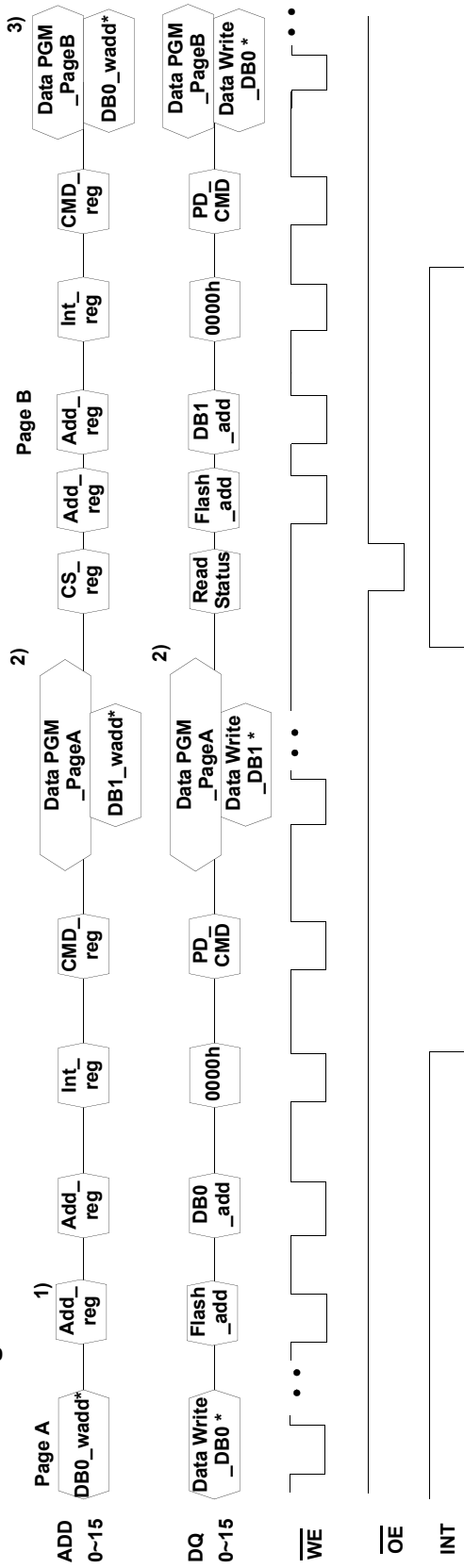

\* DBS should be set before accessing DataRAM for DDP

- Add\_reg : Address Register Address
- DBn\_wadd : DataRAM Address to be programmed
- DBn\_wadd : DataRAM Address to be written
- Data\_Write\_DBn : Write Data to DataRAMn
- Flash\_add : Flash Address to be programmed
- Int\_reg : Interrupt Register Address
- CMD\_reg : Command Register Address
- PD\_CMD : Program Command
- Data\_PGM\_PageA : Program Data from DataRAM to PageA
- CS\_reg : Controller Status Register Address

The device provides dual data buffer memory architecture. The device is capable of write operation and program operation simultaneously. This is so called the write while program operation with dual data buffer architecture, this feature provides the capability of executing write operation from host to one of data buffers during program operation from another data buffer to Flash simultaneously. Refer to the information for more details in "Program operation" before performing write while program operation. Simultaneous program and write operation to same data buffer is prohibited.

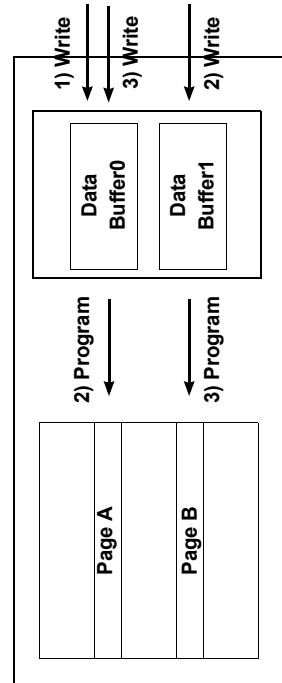

**ECC Operation**

While the device transfers data from BufferRAM to NAND Flash Array Page Buffer for Program Operation, the device hiddenly generates ECC(24bits for main area data and 10bits for 2nd and 3rd word data of each sector spare area) and while Load operation, hiddenly generates ECC and detects error number and position and corrects 1bit error. ECC is updated by the device automatically. After Load Operation, host can know whether there is error or not by reading 'ECC Status Register'(refer to ECC Status Register Table). In addition, OneNAND supports 2bit EDC even though it is little probable that 2bit error occurs. Hence, it is not recommended that Host reads 'ECC Status Register' for checking ECC error because the built-in Error Correction Logic of OneNAND finds out and corrects ECC error.

When the device loads NAND Flash Array main and spare area data with ECC operation, the device does not place the newly generated ECC for main and spare area into the buffer but places ECC which was generated and written in program operation into the buffer.

Ecc operation is done during the boot loading operation.

**ECC Bypass Operation**

ECC bypass operation is set by 9th bit of System Configuration 1 register. In ECC Bypass operation, the device neither generates ECC result which indicates error position nor updates ECC code to NAND Flash array spare area in program operation(refer to ECC Result Register Tables). During Load operation, the on-chip ECC engine does not generate a new ECC internally and the values of ECC Status and Result Registers are invalid. Hence, in ECC Bypass operation, the error cannot be detected and corrected by Mux-OneNAND itself. ECC Bypass operation is not recommended to host.

**Table 7. ECC Code & Result Status by ECC operation mode**

Operation	Program operation	Load operation		
	ECC Code Update to NAND Flash Array Spare Area	ECC Code at BufferRAM Spare Area	ECC Status & Result Update to Registers	1bit Error
ECC operation	Update	Pre-written ECC code <sup>(1)</sup> loaded	Update	Correct
ECC bypass	Not update	Pre-written code loaded	Invalid	Not correct

**NOTE:**

1. Pre-written ECC code : ECC code which is previously written to NAND Flash Spare Area in program operation.

Data Protection during Power Down

The device is designed to offer protection from any involuntary program/erase during power-transitions. An internal voltage detector disables all functions whenever Vcc is below about 1.3V. RP pin provides hardware protection and is recommended to be kept at VIL before power-down.

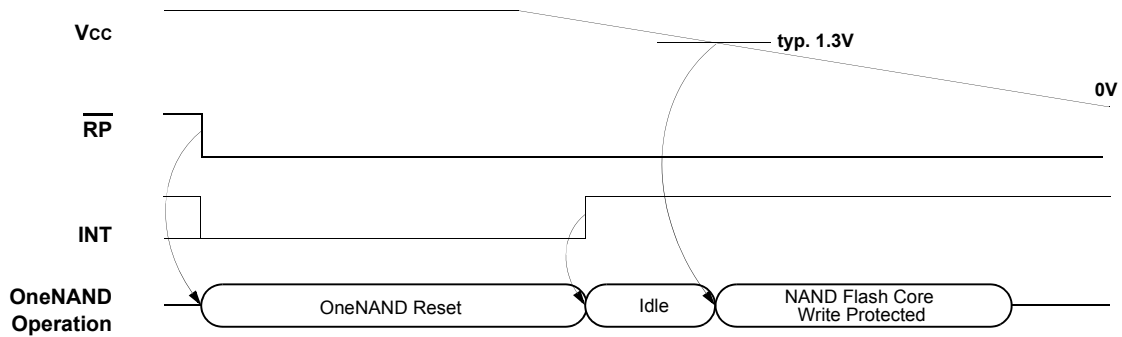

Figure 21. Data Protection during Power Down

## Technical Notes

### Invalid Block(s)

Invalid blocks are defined as blocks that contain one or more invalid bits whose reliability is not guaranteed by Samsung. The information regarding the invalid block(s) is so called as the invalid block information. Devices with invalid block(s) have the same quality level as devices with all valid blocks and have the same AC and DC characteristics. An invalid block(s) does not affect the performance of valid block(s) because it is isolated from the bit line and the common source line by a select transistor. The system design must be able to mask out the invalid block(s) via address mapping. The 1st block, which is placed on 00h block address, is fully guaranteed to be a valid block.

### Identifying Invalid Block(s)

All device locations are erased(FFFFh) except locations where the invalid block(s) information is written prior to shipping. The invalid block(s) status is defined by the 1st word in the spare area. Samsung makes sure that either the 1st or 2nd page of every invalid block has non-FFFFh data at the 1st word of sector0 spare area. Since the invalid block information is also erasable in most cases, it is impossible to recover the information once it has been erased. Therefore, the system must be able to recognize the invalid block(s) based on the original invalid block information and create the invalid block table via the following suggested flow chart. Any intentional erasure of the original invalid block information is prohibited.

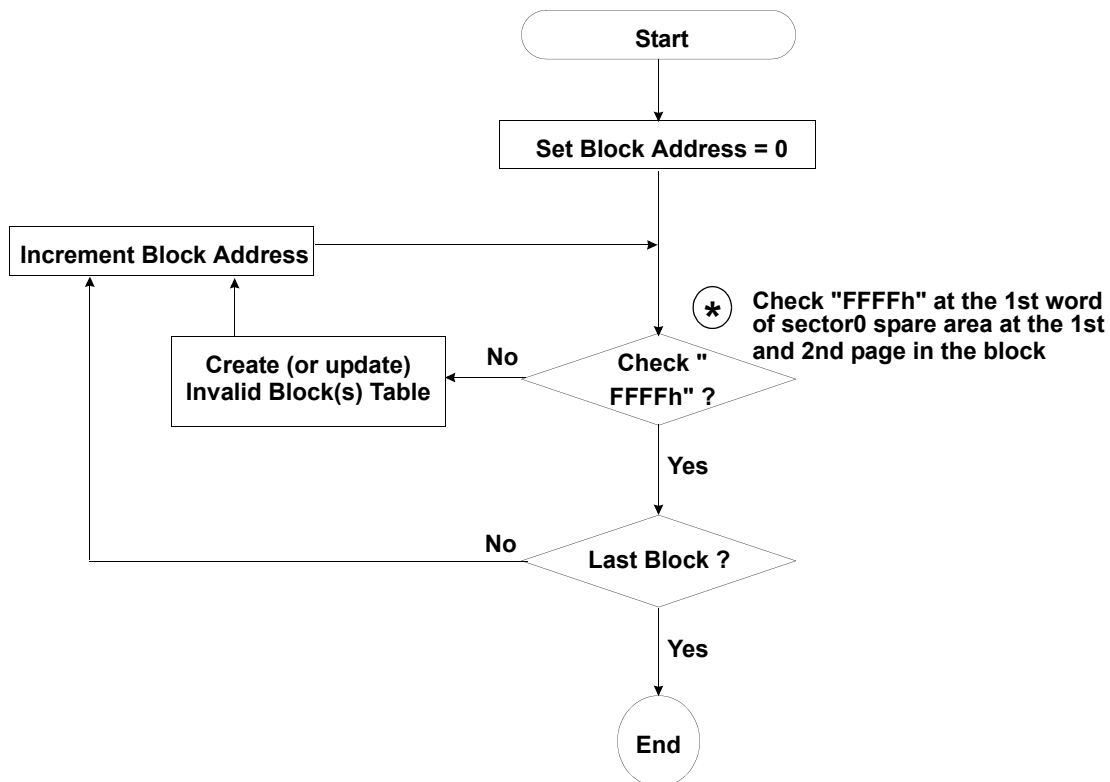

Figure 22. Flow chart to create invalid block table.

**Technical Notes** (Continued)

**Error in write or load operation**

Within its life time, additional invalid blocks may develop with the device. Refer to the qualification report for the actual data. The following possible failure modes should be considered to implement a highly reliable system. In the case of status read failure after erase or program, block replacement should be done. Because program status fail during a page program does not affect the data of the other pages in the same block, block replacement can be executed with a page-sized buffer by finding an erased empty block and reprogramming the current target data and copying the rest of the replaced block.

	Failure Mode	Detection and Countermeasure sequence
Write	Erase Failure	Status Read after Erase --> Block Replacement
	Program Failure	Status Read after Program --> Block Replacement
Load	Single Bit Failure	Error Correction by ECC mode of the device

**Block Replacement**

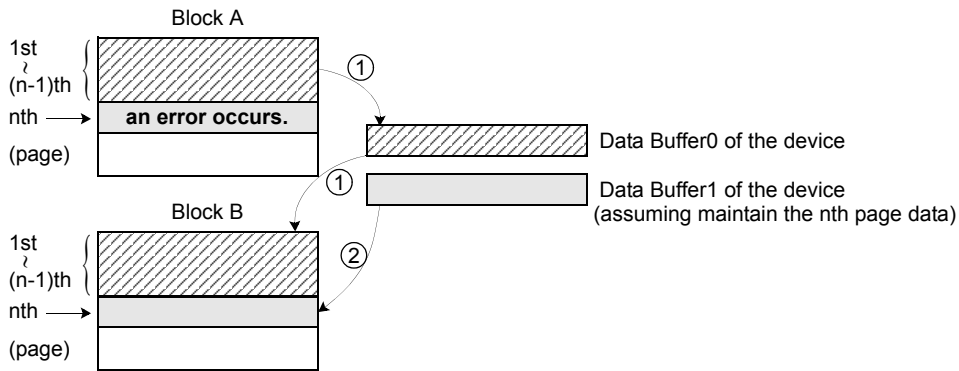

When an error happens in the nth page of the Block 'A' during program operation.

\* Step1

Then, copy the data in the 1st ~ (n-1)th page to the same location of the Block 'B' via data buffer0.

\* Step2

Copy the nth page data of the Block 'A' in the data buffer1 to the nth page of another free block. (Block 'B')

Do not further erase or program Block 'A' but create an 'invalid Block' table or other appropriate scheme.

## Technical Notes (Continued)

### OneNAND DDP Technical Note

#### DDP Chip Selection Register

OneNAND DDP configuration does not require additional pins. NAND Flash Block Address is consecutive between LSB and MSB chips. As seen in the figure below, the LSB Block Address ends at 01FFh(Block 511) and the MSB Block Address begins at 1000h(Block 512). The Device Flash Core Select (DFS) of Start Address 1 Register and the Device BufferRAM Select (DBS) of Start Address 2 Register are used to select the desired LSB or MSB Flash Core and BufferRAM in the DDP.

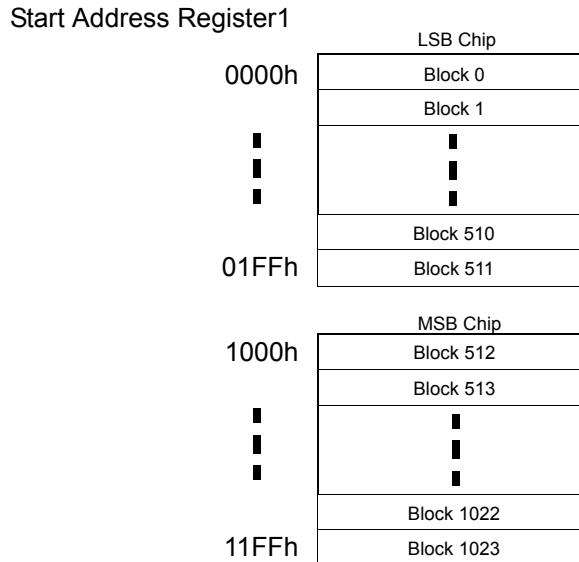

Figure 23. Flash Block Address Map in DDP

#### Start Address1 Register (R/W): F100h, default=0000h

This Read/Write register is used to select the Flash Core of the LSB or MSB device (DFS).

15	14	13	12	11	10	9	8	7	6	5	4	3	2	1	0
DFS	Reserved(000000)						FBA								

**DFS** (Device Flash Core Select): it selects Flash Core in two Flash Core of DDP

**FBA** (NAND Flash Block Address): NAND Flash block address which will be read or programmed or erased.

Chip	Start Address1 Register	Block Number
LSB Chip	0000h ~ 01FFh	Block0 ~ Block511
MSB Chip	1000h ~ 11FFh	Block512 ~ Block1023

#### Start Address2 Register (R/W): F101h, default=0000h

This Read/Write register is used to select the BufferRAM of the LSB or MSB device (DBS).

15	14	13	12	11	10	9	8	7	6	5	4	3	2	1	0
DBS	Reserved(0000000000000000)														

**DBS** (Device BufferRAM Select): it selects BufferRAM in two BufferRAM of DDP

## Technical Notes (Continued)

### DDP Chip Selection Operation

#### Flash Core Array Selection for Unlock Operation

The LSB and MSB Flash Cores in a OneNAND DDP configuration power-up in a locked state and must be unlocked before operation. Set DFS and DBS = "0" to select the LSB Chip or "1" to select the MSB chip, then issue Unlock Command Sequence: Start block address+End block address+Unlock block command (0023h).

Note that the LSB and MSB chips must each be unlocked. The default state for Device BufferRAM Select (DBS) and Device Flash Core Select (DFS) = "0", which selects the LSB chip. For more information on lock operations.

#### . LSB Chip Case

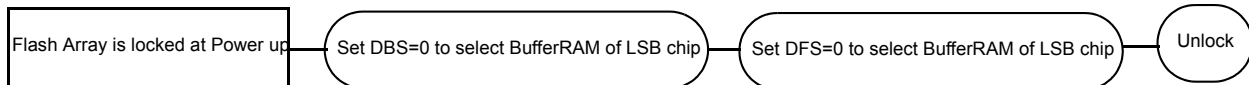

#### . MSB Chip Case

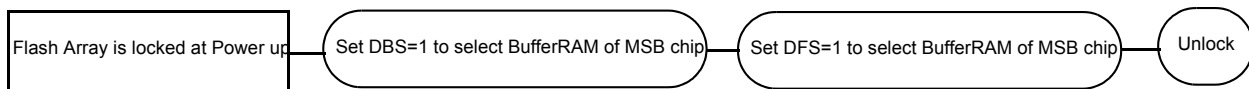

#### BufferRAM Selection for Read/Write Operation

The LSB and MSB chip BufferRAMs operate independently. Select the desired LSB or MSB chip and then execute a BufferRAM Read/Write operation. The default state for Device BufferRAM Select (DBS) and Device Flash Core Select (DFS) = "0", which selects the LSB chip.

For more information on read/write operations.

#### . LSB Chip Case

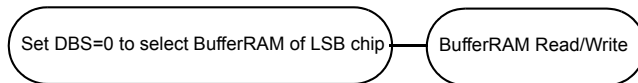

#### . MSB Chip Case

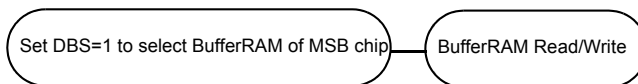

#### BufferRAM and Flash Core Selection for Load/Program/Erase/Copy-back/Cache Program/Write Protect Operation

The LSB and MSB chip BufferRAMs operate independently. Select the desired LSB or MSB chip and then execute a BufferRAM Read/Write operation. The default state for Device BufferRAM Select (DBS) and Device Flash Core Select (DFS) = "0", which selects the LSB chip.

For more information on read/write operations.

#### . LSB Chip Case

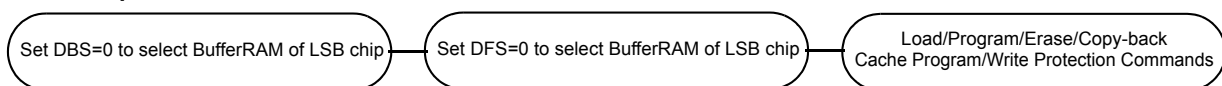

#### . MSB Chip Case

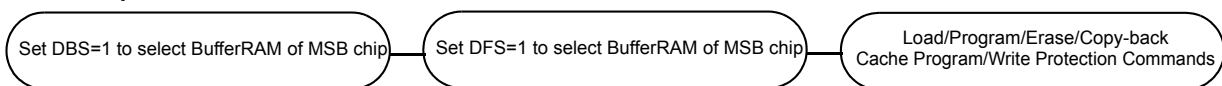

**Technical Notes** (Continued)**Boot Sequence**

One of the best features OneNAND has is that it can be a booting device itself since it contains an internally built-in boot loader despite the fact that its core architecture is based on NAND Flash. Thus, OneNAND does not make any additional booting device necessary for a system, which imposes extra cost or area overhead on the overall system.

As the system power is turned on, the boot code originally stored in NAND Flash Array is moved to BootRAM automatically and then fetched by CPU through the same interface as SRAM's or NOR Flash's if the size of the boot code is less than 1KB. If its size is larger than 1KB and less than or equal to 3KB, only 1KB of it can be moved to BootRAM automatically and fetched by CPU, and the rest of it can be loaded into one of the DataRAMs whose size is 2KB by Load Command and CPU can take it from the DataRAM after finishing the code-fetching job for BootRAM. If its size is larger than 3KB, the 1KB portion of it can be moved to BootRAM automatically and fetched by CPU, and its remaining part can be moved to DRAM through two DataRAMs using dual buffering and taken by CPU to reduce CPU fetch time.

A typical boot scheme usually used to boot the system with OneNAND is explained at Figure 24 and Figure 25. In this boot scheme, boot code is comprised of BL1, where BL stands for Boot Loader, BL2, and BL3. Moreover, the size of the boot code is larger than 3KB (the 3rd case above). BL1 is called primary boot loader in other words. Here is the table of detailed explanations about the function of each boot loader in this specific boot scheme.

**Boot Loaders in OneNAND**

Boot Loader	Description
BL1	Moves BL2 from NAND Flash Array to DRAM through two DataRAMs using dual buffering
BL2	Moves OS image (or BL3 optionally) from NAND Flash Array to DRAM through two DataRAMs using dual buffering
BL3 (Optional)	Moves or writes the image through USB interface

NAND Flash Array of OneNAND is divided into the partitions as described at Figure 24 to show where each component of code is located and how much portion of the overall NAND Flash Array each one occupies. In addition, the boot sequence is listed below and depicted at Figure 25.

**Boot Sequence :**

1. Power is on  
BL1 is loaded into BootRAM
2. BL1 is executed in BootRAM  
BL2 is loaded into DRAM through two DataRAMs using dual buffering by BL1
3. BL2 is executed in DRAM  
OS image is loaded into DRAM through two DataRAMs using dual buffering by BL2
4. OS is running

Technical Notes (Continued)

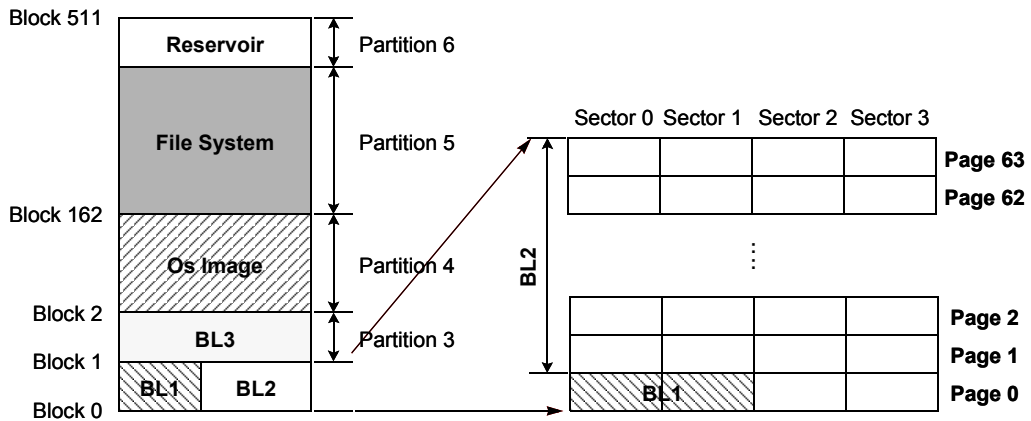
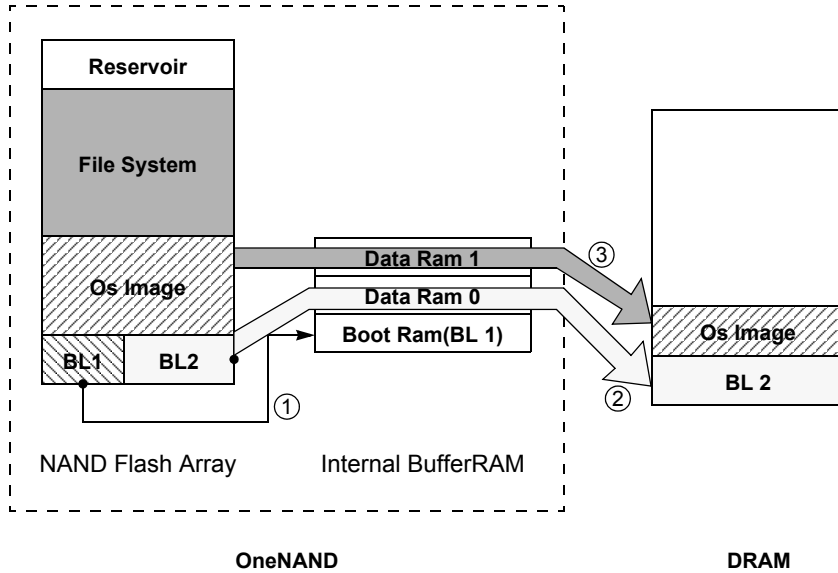

Figure 24. Partition of NAND Flash array



NOTE:  
 ② and ③ can be copied into DRAM through two DataRAMs using dual buffering

Figure 25. OneNAND Boot Sequence

**Technical Notes** (Continued)**Methods of Determining Interrupt Status**

There are two methods of determining Interrupt Status on the OneNAND. Using the INT pin or monitoring the Interrupt Status Register Bit.

The OneNAND INT pin is an output pin function used to notify the Host when a command has been completed. This provides a hardware method of signaling the completion of a program, erase, or load operation.

In its normal state, the INT pin is high if the INT polarity bit is default. Before a command is written to the command register, the INT bit must be written to '0' so the INT pin transitions to a low state indicating start of the operation. Upon completion of the command operation by the OneNAND's internal controller, INT returns to a high state.

INT is an open drain output allowing multiple INT outputs to be Or-tied together. INT does not float to a hi-Z condition when the chip is deselected or when outputs are disabled. Refer to section 2.8 for additional information about INT.

INT can be implemented by tying INT to a host GPIO or by continuous polling of the Interrupt status register.

**The INT Pin to a Host General Purpose I/O**

INT can be tied to a Host GPIO to detect the rising edge of INT, signaling the end of a command operation.

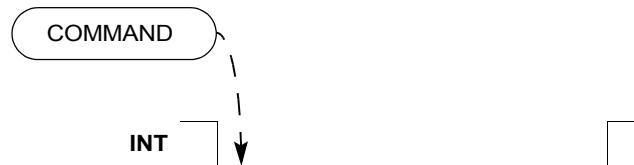

This can be configured to operate either synchronously or asynchronously as shown in the diagrams below.

## Technical Notes (Continued)

### Synchronous Mode Using the INT Pin

When operating synchronously, INT is tied directly to a Host GPIO.

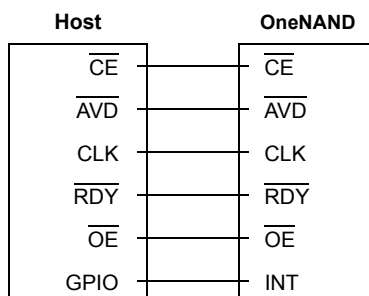

### Asynchronous Mode Using the INT Pin

When configured to operate in an asynchronous mode, /CE and /AVD of the OneNAND are tied to /CE of the Host. CLK is tied to the Host Vss (Ground). /RDY is tied to a no-connect. /OE of the OneNAND and Host are tied together and INT is tied to a GPIO.

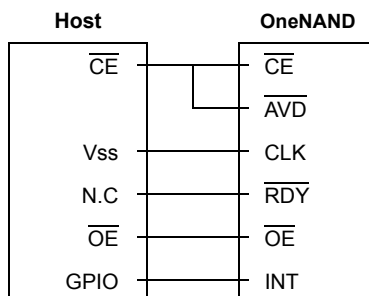

### Polling the Interrupt Register Status Bit

An alternate method of determining the end of an operation is to continuously monitor the Interrupt Status Register Bit instead of using the INT pin.

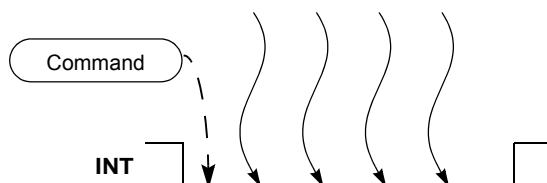

This can be configured in either a synchronous mode or an asynchronous mode.

## Technical Notes (Continued)

### Synchronous Mode Using Interrupt Status Register Bit Polling

When operating synchronously, /CE, /AVD, CLK, /RDY, /OE, and DQ pins on the host and OneNAND are tied together.

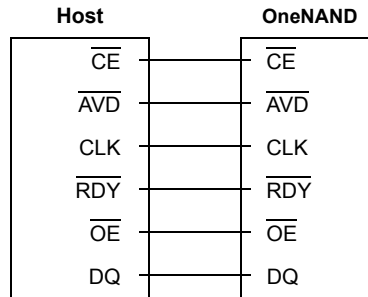

### Asynchronous Mode Using Interrupt Status Register Bit Polling

When configured to operate in an asynchronous mode, /CE and /AVD of the OneNAND are tied to /CE of the Host. CLK is tied to the Host Vss (Ground). /RDY is tied to a no-connect. /OE and DQ of the OneNAND and Host are tied together.

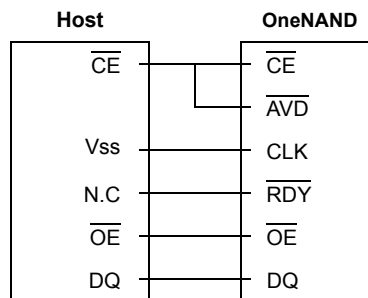

## Technical Notes (Continued)

### Determining Rp Value

Because the pull-up resistor value is related to  $t_r(\text{INT})$ , an appropriate value can be obtained by the following reference charts.

### INT pol = 'High'

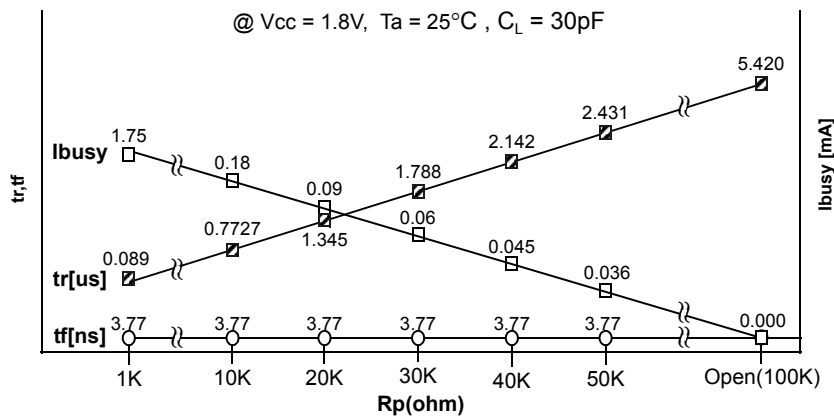
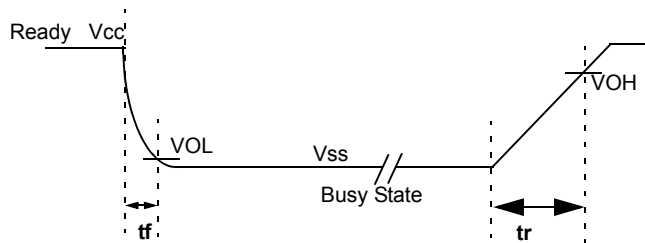
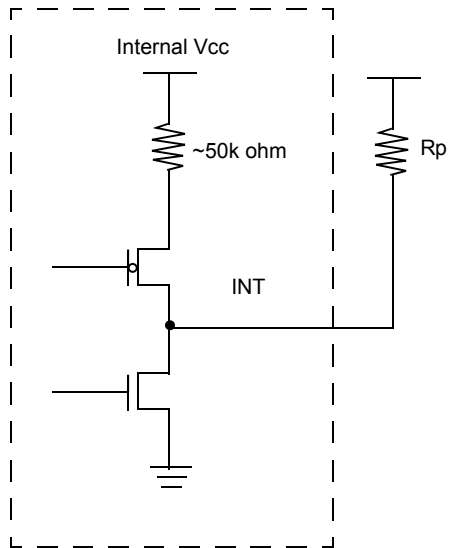

Technical Notes (Continued)

INT pol = 'Low'

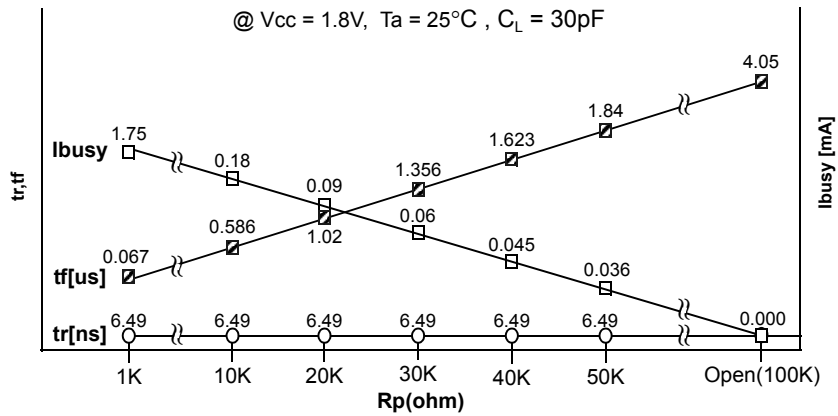
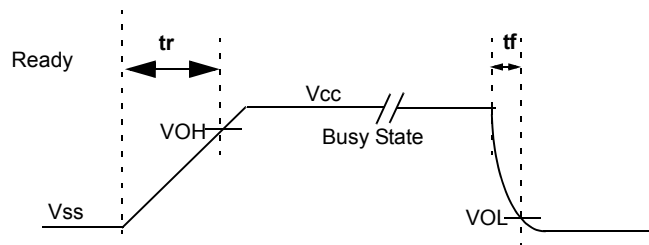
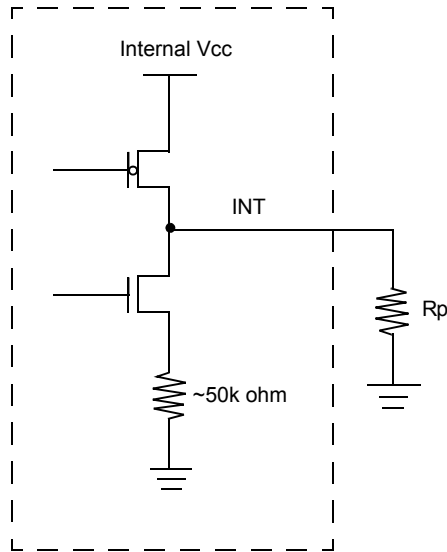

## ABSOLUTE MAXIMUM RATINGS

Parameter		Symbol	Rating			Unit
			KFG1216Q2M KFH1G16Q2M	KFG1216D2M KFH1G16D2M	KFG1216U2M KFH1G16U2M	
Voltage on any pin relative to Vss	Vcc	Vcc	-0.5 to + 2.45	-0.6 to + 4.6	-0.6 to + 4.6	V
	All Pins	VIN	-0.5 to + 2.45	-0.6 to + 4.6	-0.6 to + 4.6	
Temperature Under Bias	Extended	T <sub>bias</sub>	-30 to +125	-30 to +125	-30 to +125	°C
	Industrial		-	-	-40 to +125	
Storage Temperature		T <sub>stg</sub>	-65 to +150	-65 to +150	-65 to +150	°C
Short Circuit Output Current		I <sub>os</sub>	5	5	5	mA
Operating Temperature		T <sub>A</sub> (Extended Temp.)	-30 to + 85	-30 to + 85	-	°C
		T <sub>A</sub> (Industrial Temp.)	-	-	-40 to + 85	

## NOTES:

- Minimum DC voltage is -0.5V on Input/ Output pins. During transitions, this level should not fall to POR level(typ. 1.5V) .  
Maximum DC voltage is Vcc+0.6V on input / output pins which, during transitions, may overshoot to Vcc+2.0V for periods <20ns.
- Permanent device damage may occur if ABSOLUTE MAXIMUM RATINGS are exceeded. Functional operation should be restricted to the conditions detailed in the operational sections of this data sheet. Exposure to absolute maximum rating conditions for extended periods may affect reliability.

## RECOMMENDED OPERATING CONDITIONS ( Voltage reference to GND )

Parameter	Symbol	1.8V Device			2.65V Device			3.3V Device			Unit
		Min	Typ.	Max	Min	Typ.	Max	Min	Typ.	Max	
Supply Voltage	Vcc-Core/ Vcc-IO	1.7	1.8	1.95	2.4	2.65	2.9	2.7	3.3	3.6	V
Supply Voltage	Vss	0	0	0	0	0	0	0	0	0	V

## NOTES:

- The system power should reach 1.7V after POR triggering level(typ. 1.5V) within 400us.
- Vcc-Core should reach the operating voltage level prior to Vcc-IO.

## DC CHARACTERISTICS

Parameter	Symbol	Test Conditions	1.8V device			2.65V device			3.3V device			Unit	
			Min	Typ	Max	Min	Typ	Max	Min	Typ	Max		
Input Leakage Current	I <sub>LI</sub>	V <sub>IN</sub> =V <sub>SS</sub> to V <sub>CC</sub> , V <sub>CC</sub> =V <sub>CCmax</sub>	-1.0	-	+1.0	-1.0	-	+1.0	-1.0	-	+1.0	μA	
Output Leakage Current	I <sub>LO</sub>	V <sub>OUT</sub> =V <sub>SS</sub> to V <sub>CC</sub> , V <sub>CC</sub> =V <sub>CCmax</sub> , $\overline{CE}$ or $\overline{OE}$ =V <sub>IH</sub> (Note 1)	-1.0	-	+1.0	-1.0	-	+1.0	-1.0	-	+1.0	μA	
Active Asynchronous Read Current (Note 2)	I <sub>CC1</sub>	$\overline{CE}$ =V <sub>IL</sub> , $\overline{OE}$ =V <sub>IH</sub>	-	8	15	-	10	20	-	10	20	mA	
Active Burst Read Current (Note 2)	I <sub>CC2</sub>	$\overline{CE}$ =V <sub>IL</sub> , $\overline{OE}$ =V <sub>IH</sub>	54MHz	-	12	20	-	20	30	-	20	30	mA
			1MHz	-	3	4	-	4	6	-	4	6	mA
Active Write Current (Note 2)	I <sub>CC3</sub>	$\overline{CE}$ =V <sub>IL</sub> , $\overline{OE}$ =V <sub>IH</sub>	-	8	15	-	10	20	-	10	20	mA	
Active Load Current (Note 3)	I <sub>CC4</sub>	$\overline{CE}$ =V <sub>IL</sub> , $\overline{OE}$ =V <sub>IH</sub> , $\overline{WE}$ =V <sub>IH</sub> , V <sub>IN</sub> =V <sub>IH</sub> or V <sub>IL</sub>	-	20	25	-	25	30	-	25	30	mA	
Active Program Current (Note 3)	I <sub>CC5</sub>	$\overline{CE}$ =V <sub>IL</sub> , $\overline{OE}$ =V <sub>IH</sub> , $\overline{WE}$ =V <sub>IH</sub> , V <sub>IN</sub> =V <sub>IH</sub> or V <sub>IL</sub>	-	20	25	-	25	30	-	25	30	mA	
Active Erase Current (Note3)	I <sub>CC6</sub>	$\overline{CE}$ =V <sub>IL</sub> , $\overline{OE}$ =V <sub>IH</sub> , $\overline{WE}$ =V <sub>IH</sub> , V <sub>IN</sub> =V <sub>IH</sub> or V <sub>IL</sub>	-	15	20	-	20	25	-	20	25	mA	
Standby Current	I <sub>SB</sub>	$\overline{CE} = \overline{RP} = V_{CC} \pm 0.2V$	Single	-	10	50	-	20	50	-	20	50	μA
			DDP	-	20	100	-	40	100	-	40	100	
Input Low Voltage	V <sub>IL</sub>	-	-0.5	-	0.4	-0.5	-	0.4	0	-	0.8	V	
Input High Voltage	V <sub>IH</sub>	-	V <sub>CCIO</sub> -0.4	-	V <sub>CCIO</sub> +0.4	V <sub>CCIO</sub> -0.4	-	V <sub>CCIO</sub> +0.4	0.7* V <sub>CCIO</sub>	-	0.7* V <sub>CCIO</sub>	V	
Output Low Voltage	V <sub>OL</sub>	I <sub>OL</sub> = 100 μA, V <sub>CC</sub> =V <sub>CCmin</sub> , V <sub>CCq</sub> =V <sub>CCqmin</sub>	-	-	0.2	-	-	0.2	-	-	0.22* V <sub>CCIO</sub>	V	
Output High Voltage	V <sub>OH</sub>	I <sub>OH</sub> = -100 μA, V <sub>CC</sub> =V <sub>CCmin</sub> , V <sub>CCq</sub> =V <sub>CCqmin</sub>	V <sub>CCIO</sub> -0.1	-	-	V <sub>CCIO</sub> -0.4	-	-	0.8* V <sub>CCIO</sub>	-	-	V	

## NOTES:

- $\overline{CE}$  should be V<sub>IH</sub> for RDY. IOBE should be '0' for INT
- I<sub>CC</sub> active for Host access
- I<sub>CC</sub> active while Internal operation is in progress

## VALID BLOCK

Parameter	Symbol	Min	Typ.	Max	Unit
Valid Block Number	NvB	502	-	512	Blocks

Note :

1. The device may include invalid blocks when first shipped. Additional invalid blocks may develop while being used. The number of valid blocks is presented with both cases of invalid blocks considered. Invalid blocks are defined as blocks that contain one or more bad bits. Do not erase or program factory-marked bad blocks.
2. The 1st block, which is placed on 00h block address, is fully guaranteed to be a valid block.

## CAPACITANCE (T<sub>A</sub> = 25 °C, V<sub>CC</sub> = 1.8V/2.65V/3.3V, f = 1.0MHz)

Item	Symbol	Test Condition	Single		DDP		Unit
			Min	Max	Min	Max	
Input Capacitance	C <sub>IN1</sub>	V <sub>IN</sub> =0V	-	10	-	20	pF
Control Pin Capacitance	C <sub>IN2</sub>	V <sub>IN</sub> =0V	-	10	-	20	pF
Output Capacitance	C <sub>OUT</sub>	V <sub>OUT</sub> =0V	-	10	-	20	pF

**NOTE** : Capacitance is periodically sampled and not 100% tested.

## AC TEST CONDITION (V<sub>CC</sub> = 1.8V/2.65V/3.3V)

Parameter	Value
Input Pulse Levels	0V to V <sub>CC</sub>
Input Rise and Fall Times	CLK
	other inputs
Input and Output Timing Levels	V <sub>CC</sub> /2
Output Load	C <sub>L</sub> = 30pF

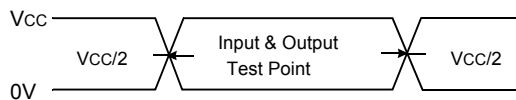

**Input Pulse and Test Point**

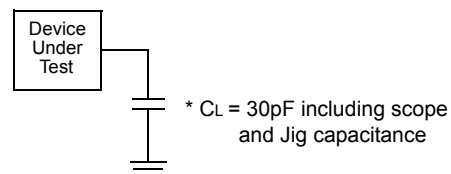

**Output Load**

## AC CHARACTERISTICS

### Synchronous Burst Read

Parameter	Symbol	KFG1216X2M/KFH1G16X2M		Unit
		Min	Max	
Clock	CLK	1	54	MHz
Clock Cycle	tCLK	18.5	-	ns
Initial Access Time(at 54MHz)	t <sub>IAA</sub>	-	88.5	ns
Burst Access Time Valid Clock to Output Delay	t <sub>BA</sub>	-	14.5	ns
$\overline{\text{AVD}}$ Setup Time to CLK	t <sub>AVDS</sub>	7	-	ns
$\overline{\text{AVD}}$ Hold Time from CLK	t <sub>AVDH</sub>	7	-	ns
Address Setup Time to CLK	t <sub>ACS</sub>	7	-	ns
Address Hold Time from CLK	t <sub>ACH</sub>	7	-	ns
Data Hold Time from Next Clock Cycle	t <sub>BDH</sub>	4	-	ns
Output Enable to Data	t <sub>OE</sub>	-	20	ns
$\overline{\text{CE}}$ Disable to Output High Z	t <sub>CEZ</sub> <sup>1)</sup>	-	20	ns
$\overline{\text{OE}}$ Disable to Output High Z	t <sub>OEZ</sub> <sup>1)</sup>	-	17	ns
$\overline{\text{CE}}$ Setup Time to CLK	t <sub>CES</sub>	7	-	ns
CLK High or Low Time	t <sub>CLKH/L</sub>	t <sub>CLK</sub> /3	-	ns
CLK <sup>2)</sup> to RDY valid	t <sub>RDYO</sub>	-	14.5	ns
CLK to RDY Setup Time	t <sub>RDYA</sub>	-	14.5	ns
RDY Setup Time to CLK	t <sub>RDYS</sub>	4	-	ns
$\overline{\text{CE}}$ low to RDY valid	t <sub>CER</sub>	-	15	ns

#### Note

1. If  $\overline{\text{OE}}$  is disabled before  $\overline{\text{CE}}$  is disabled, the output will go to high-z by t<sub>OEZ</sub>(max. 17ns).  
If  $\overline{\text{CE}}$  is disabled before  $\overline{\text{OE}}$  is disabled, the output will go to high-z by t<sub>CEZ</sub>(max. 20ns).  
If  $\overline{\text{CE}}$  and  $\overline{\text{OE}}$  are disabled at the same time, the output will go to high-z by t<sub>OEZ</sub>(max. 17ns).
2. It is the following clock of address fetch clock.

SWITCHING WAVEFORMS

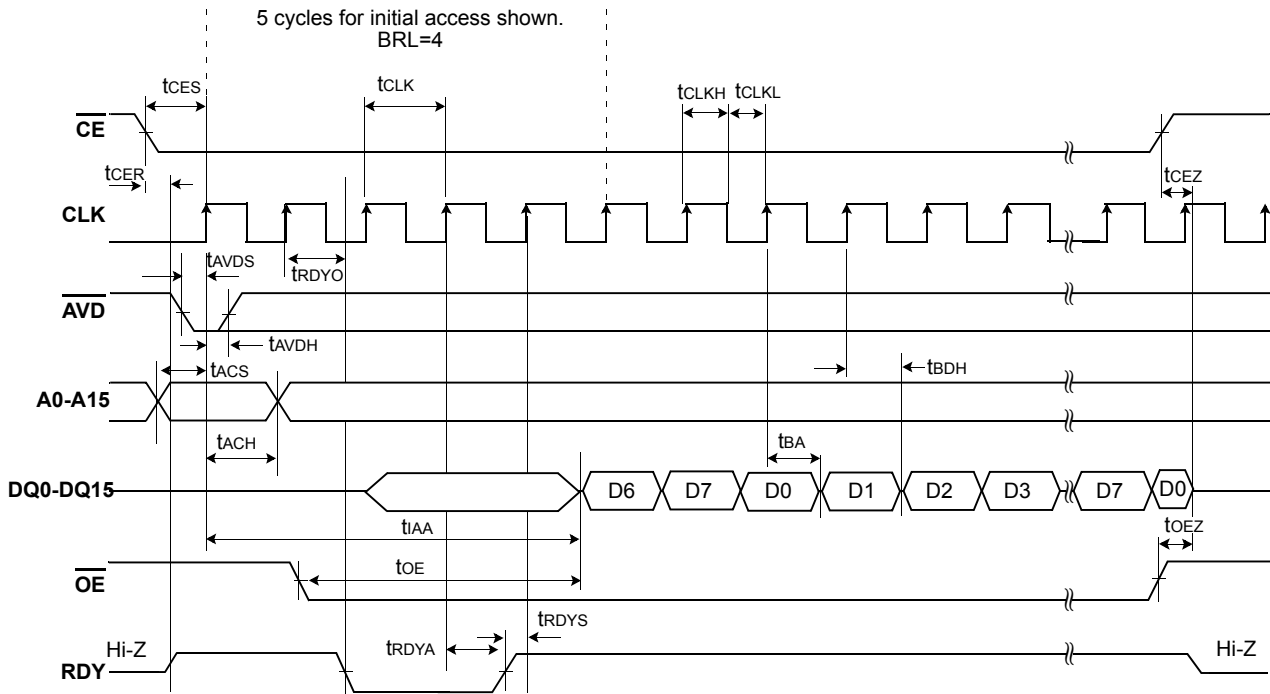

Figure 26. 8 Word Linear Burst Mode with Wrap Around

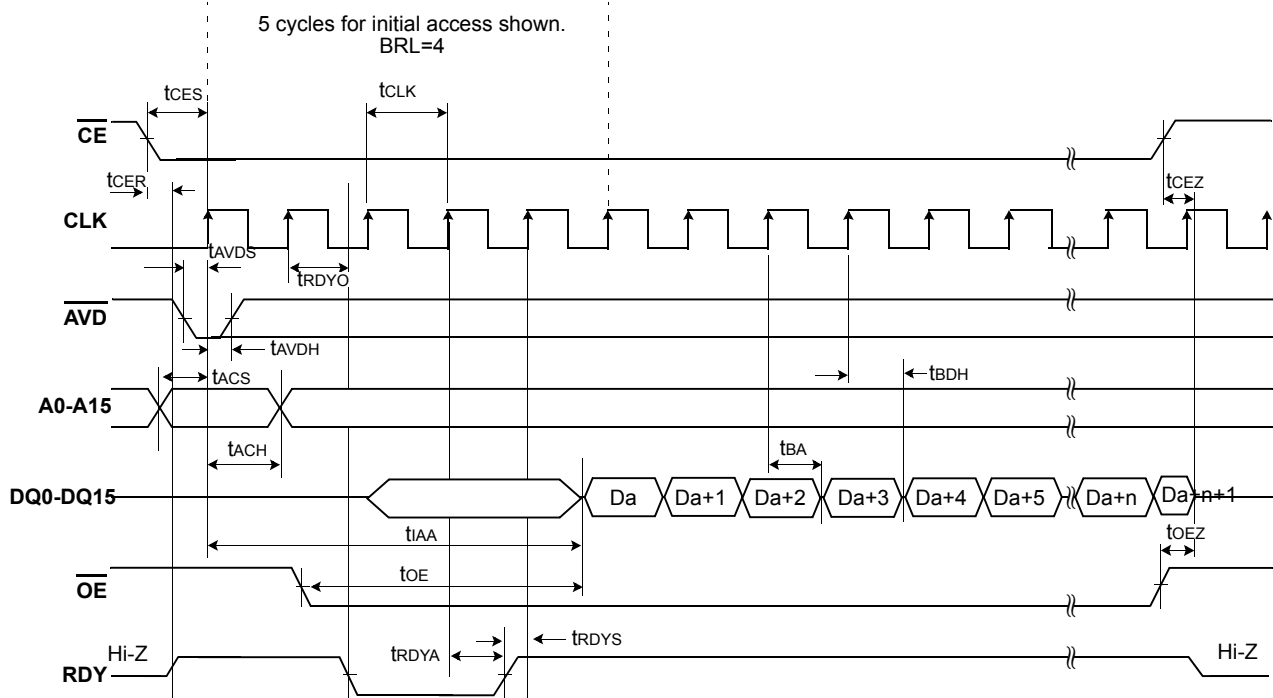

Figure 27. Continuous Linear Burst Mode with Wrap Around

NOTE: In order to avoid a bus conflict the  $\overline{OE}$  signal is enabled on the next rising edge after  $\overline{AVD}$  is going high.

**AC CHARACTERISTICS**  
**Asynchronous Read**

Parameter	Symbol	KFG1216X2M/KFH1G16X2M		Unit
		Min	Max	
Access Time from $\overline{CE}$ Low	tCE	-	76	ns
Asynchronous Access Time from $\overline{AVD}$ Low	tAA	-	76	ns
Asynchronous Access Time from address valid	tACC	-	76	ns
Read Cycle Time	tRC	76	-	ns
$\overline{AVD}$ Low Time	tAVDP	12	-	ns
Address Setup to rising edge of $\overline{AVD}$	tAAVDS	7	-	ns
Address Hold from rising edge of $\overline{AVD}$	tAAVDH	7	-	ns
Output Enable to Output Valid	tOE	-	20	ns
$\overline{WE}$ Disable to $\overline{AVD}$ Enable	tWEA	15	-	ns
$\overline{CE}$ Setup to $\overline{AVD}$ falling edge	tCA	0	-	ns
$\overline{CE}$ Disable to Output & RDY High Z <sup>1)</sup>	tCEZ	-	20	ns
$\overline{OE}$ Disable to Output & RDY High Z <sup>1)</sup>	tOEZ	-	17	ns

**NOTE:**

1. If  $\overline{OE}$  is disabled before  $\overline{CE}$  is disabled, the output will go to high-z by tOEZ(max. 17ns).  
 If  $\overline{CE}$  is disabled before  $\overline{OE}$  is disabled, the output will go to high-z by tCEZ(max. 20ns).  
 If  $\overline{CE}$  and  $\overline{OE}$  are disabled at the same time, the output will go to high-z by tOEZ(max. 17ns).  
 These parameters are not tested 100%.

**SWITCHING WAVEFORMS**

Case 1 : Valid Address and  $\overline{AVD}$  Transition occur before  $\overline{CE}$  is driven to Low

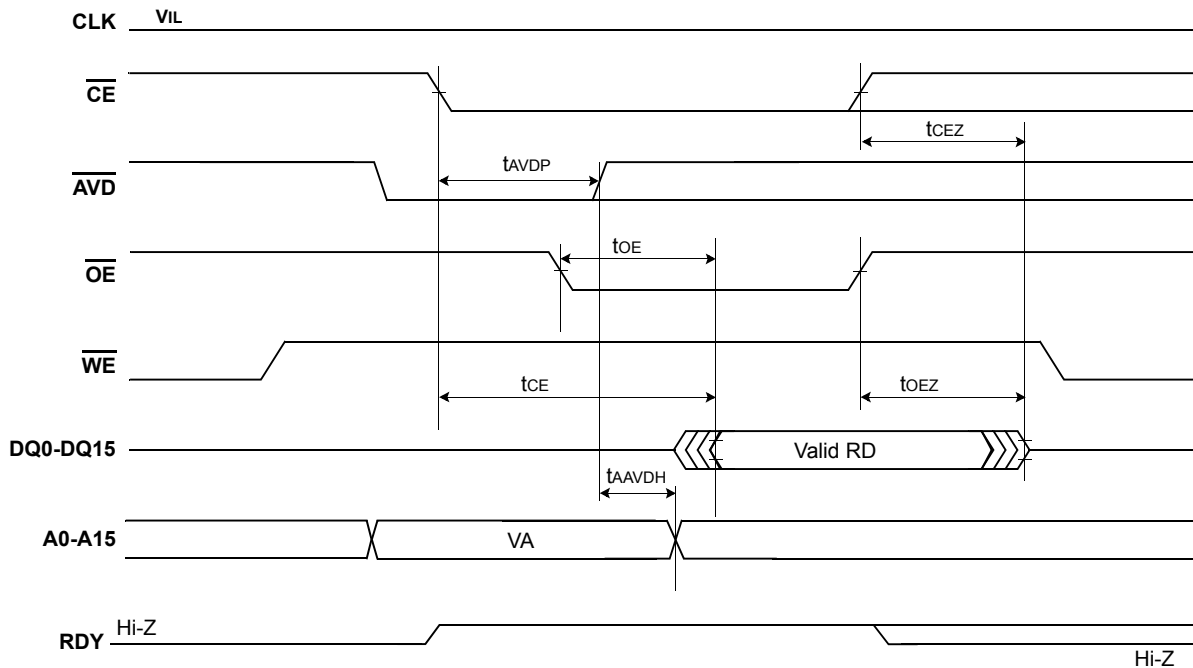

NOTE: VA=Valid Read Address, RD=Read Data.

**Figure 28 . Asynchronous Read Mode( $\overline{AVD}$  toggling)**

Case 2 :  $\overline{\text{AVD}}$  Transition occurs after  $\overline{\text{CE}}$  is driven to Low and Valid Address Transition occurs before  $\overline{\text{AVD}}$  is driven to Low

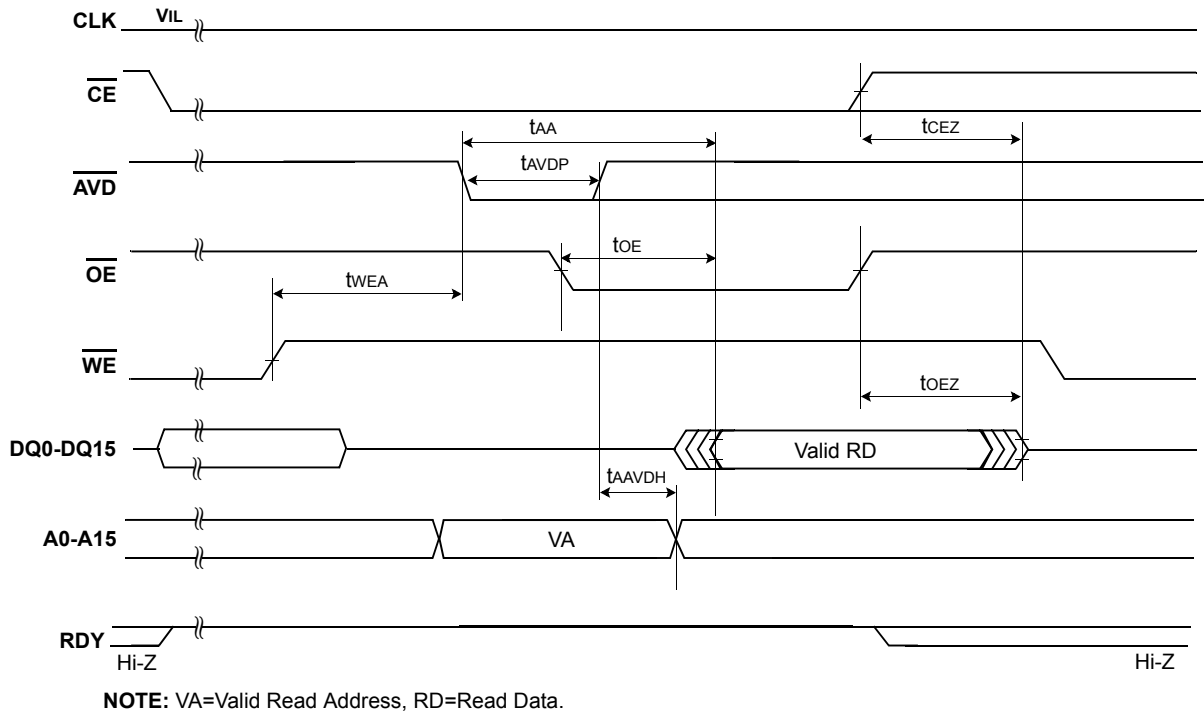

Figure 29. Asynchronous Read Mode( $\overline{\text{AVD}}$  toggling)

Case 3 :  $\overline{\text{AVD}}$  Transition occur after  $\overline{\text{CE}}$  is driven to Low and Valid Address Transition occurs after  $\overline{\text{AVD}}$  is driven to Low

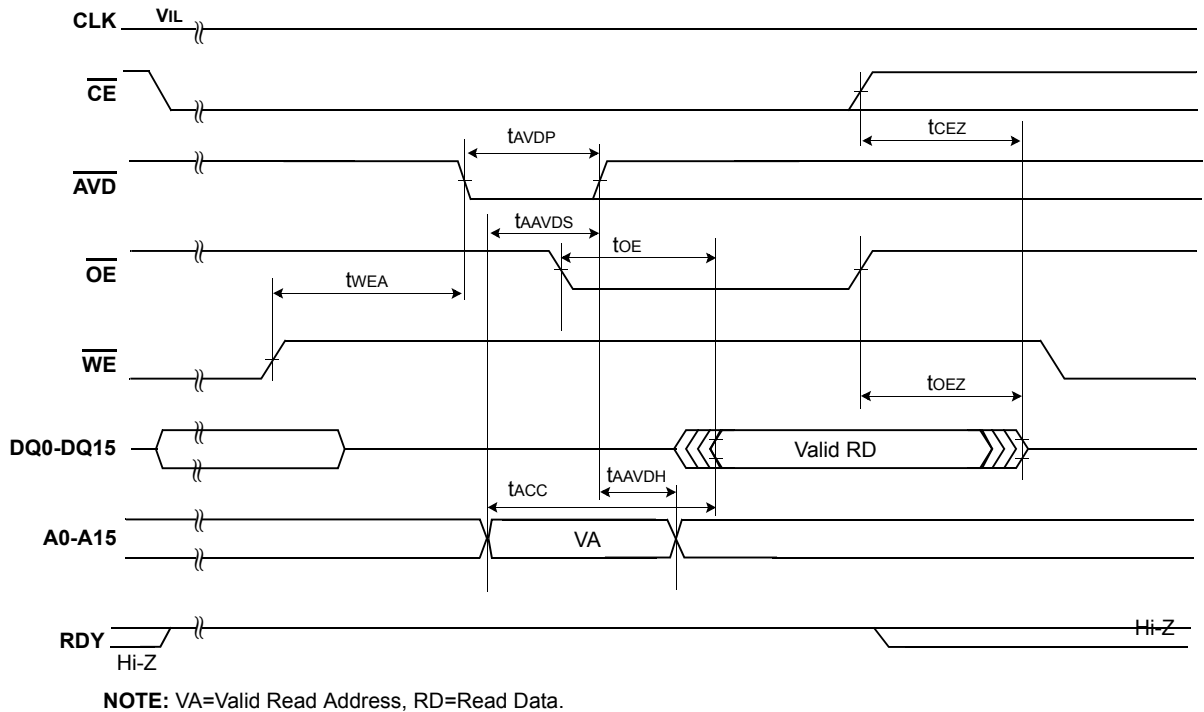
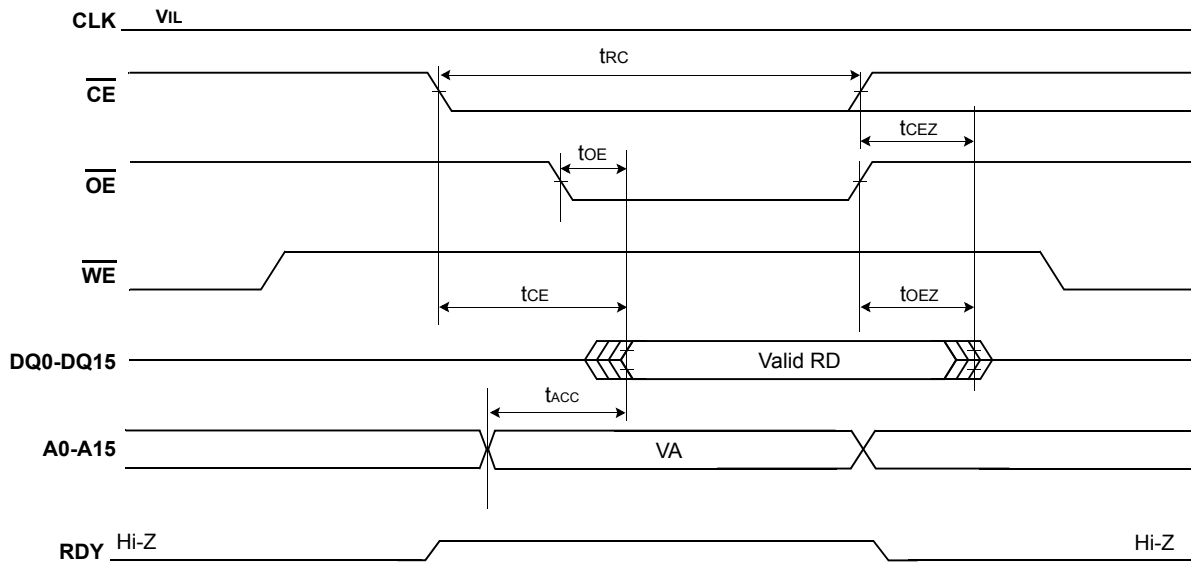

Figure 30. Asynchronous Read Mode( $\overline{\text{AVD}}$  toggling)

Case 4 :  $\overline{\text{AVD}}$  is tied to  $\overline{\text{CE}}$



NOTE: VA=Valid Read Address, RD=Read Data.

Figure 31. Asynchronous Read Mode( $\overline{\text{AVD}}$  tied to  $\overline{\text{CE}}$ )

## AC CHARACTERISTICS

## Asynchronous write operation

Parameter	Symbol	KFG1216X2M/KFH1G16X2M			Unit
		Min	Typ	Max	
$\overline{WE}$ Cycle Time	tWC	70	-	-	ns
$\overline{AVD}$ low pulse width	tAVDP	12	-	-	ns
Address Setup to rising edge of $\overline{AVD}$	tAAVDS	7	-	-	ns
Address Setup to falling edge of $\overline{WE}$	tAWES	0			
Address Hold to rising edge of $\overline{AVD}$	tAAVDH	7	-	-	ns
Address Hold to falling edge of $\overline{WE}$	tAH	10			ns
Data Setup to rising edge of $\overline{WE}$	tDS	10	-	-	ns
Data Hold from rising edge of $\overline{WE}$	tDH	4	-	-	ns
$\overline{CE}$ Setup to falling edge of $\overline{WE}$	tCS	0	-	-	ns
$\overline{CE}$ Hold from rising edge of $\overline{WE}$	tCH1	0	-	-	ns
$\overline{CE}$ Hold from rising edge of $\overline{WE}$					
$\overline{CE}$ Hold from rising edge of $\overline{WE}$	tCH2	10	-	-	ns
$\overline{WE}$ Pulse Width	tWPL	40	-	-	ns
$\overline{WE}$ Pulse Width High	tWPH	30	-	-	ns
$\overline{AVD}$ Disable to $\overline{WE}$ Disable	tVLWH	15	-	-	ns
$\overline{WE}$ Disable to $\overline{AVD}$ Enable	tWEA	15	-	-	ns

Case 1 :  $\overline{\text{AVD}}$  is toggled every write cycle

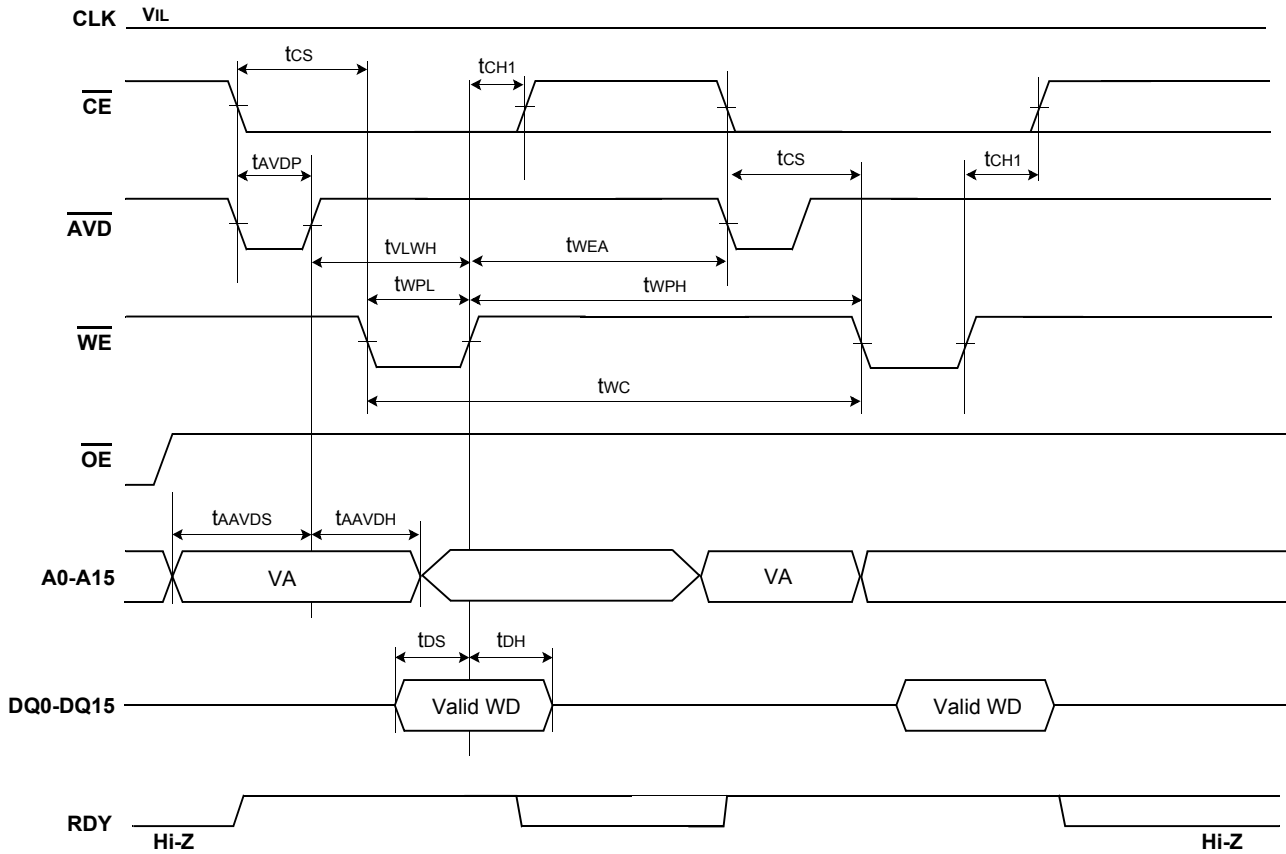

NOTE: VA=Valid Read Address, WD=Write Data.

Figure 32. Latched Asynchronous Write Mode( $\overline{\text{AVD}}$  toggling)

Case 2 :  $\overline{\text{AVD}}$  is synchronized with  $\overline{\text{CE}}$

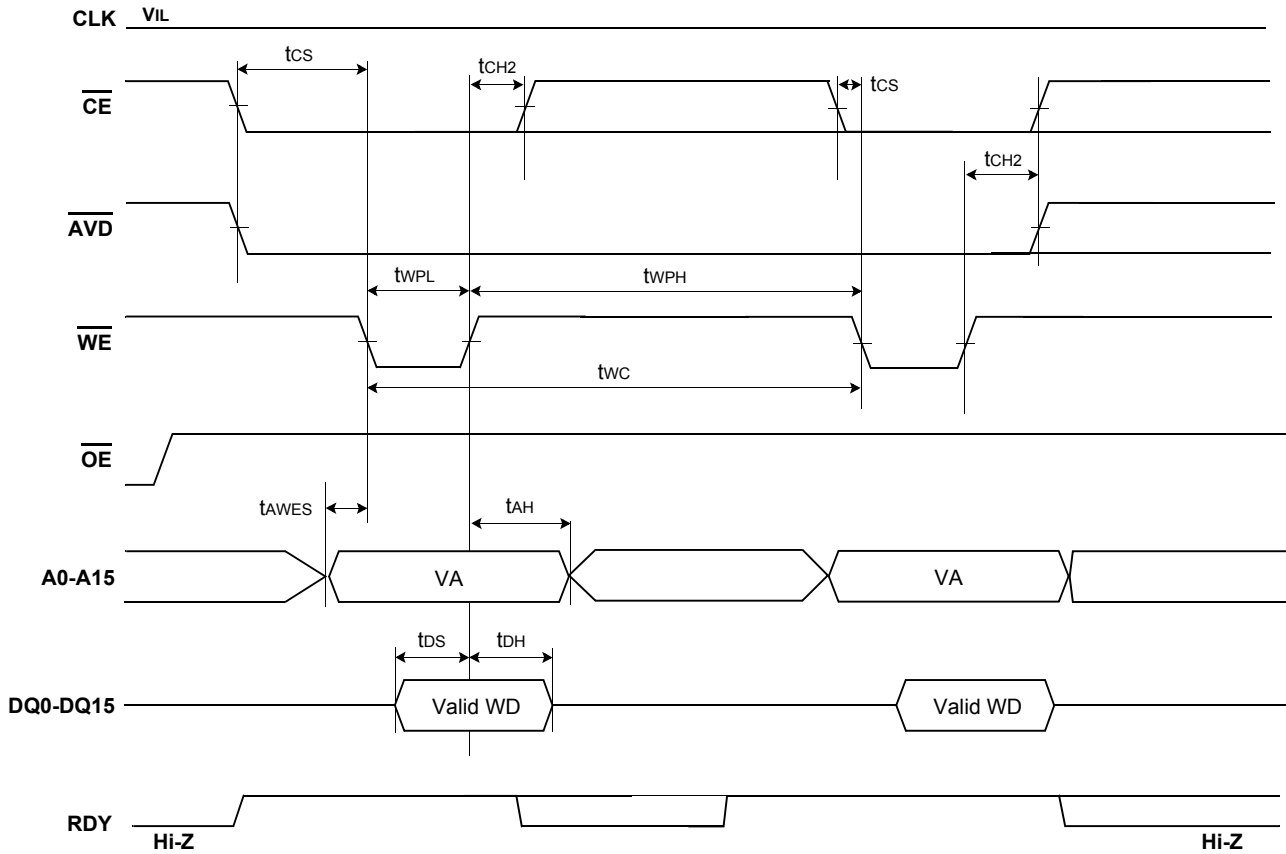

NOTE: VA=Valid Read Address, WD=Write Data.

Figure 33. Asynchronous Write Mode( $\overline{\text{AVD}}$  toggling)

Case 3 :  $\overline{\text{AVD}}$  is tied to  $\overline{\text{CE}}$

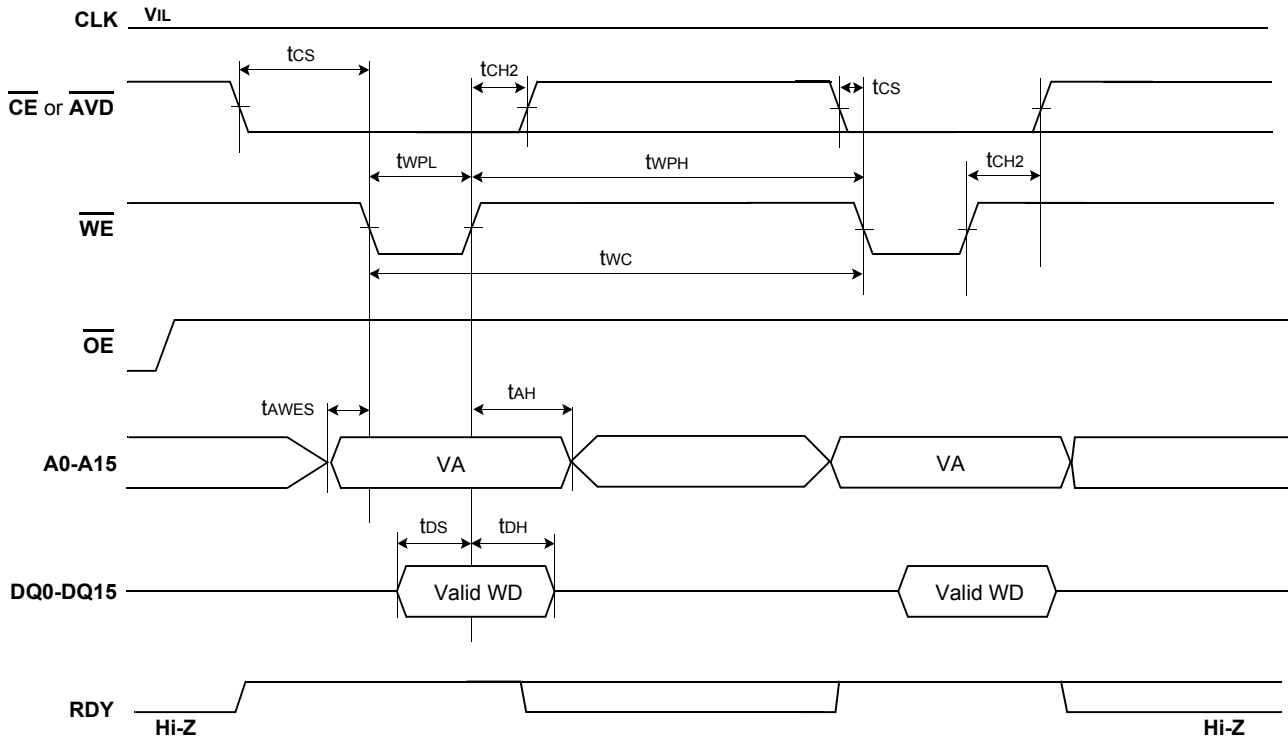

NOTE: VA=Valid Read Address, WD=Write Data.

Figure 34. Asynchronous Write Mode( $\overline{\text{AVD}}$  tied to  $\overline{\text{CE}}$ )

AC CHARACTERISTICS

Reset

Parameter	Symbol	KFG1216U2M/ KFH1G16X2M		Unit
		Min	Max	
$\overline{RP}$ & Reset Command Latch(During Load Routines) to INT High (Note)	tRST	-	10	$\mu$ s
$\overline{RP}$ & Reset Command Latch(During Program Routines) to INT High (Note)	tRST	-	20	$\mu$ s
$\overline{RP}$ & Reset Command Latch(During Erase Routines) to INT High (Note)	tRST	-	500	$\mu$ s
$\overline{RP}$ & Reset Command Latch(NOT During Internal Routines) to Read Mode (Note)	tRST	-	10	$\mu$ s
INT High to Read Mode (Note)	tReady	200	-	ns
$\overline{RP}$ Pulse Width	tRP	200	-	ns

NOTE: These parameters are tested based on INT bit of interrupt register. Because the time on INT pin is related to the pull-up and pull-down resistor value. Please refer to page 73 and 74.

SWITCHING WAVEFORMS

Warm Reset

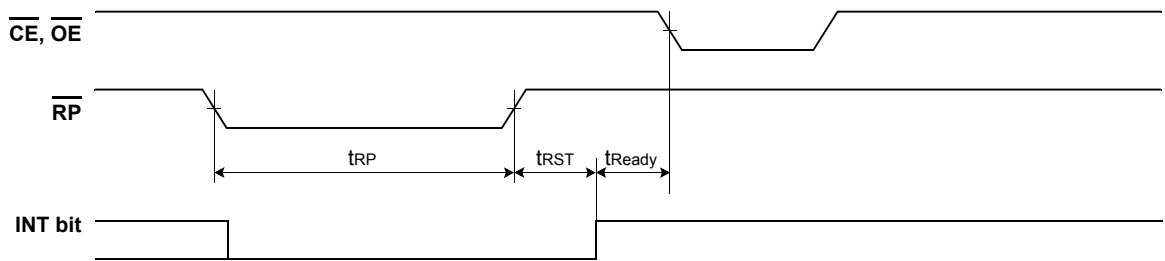

Hot Reset

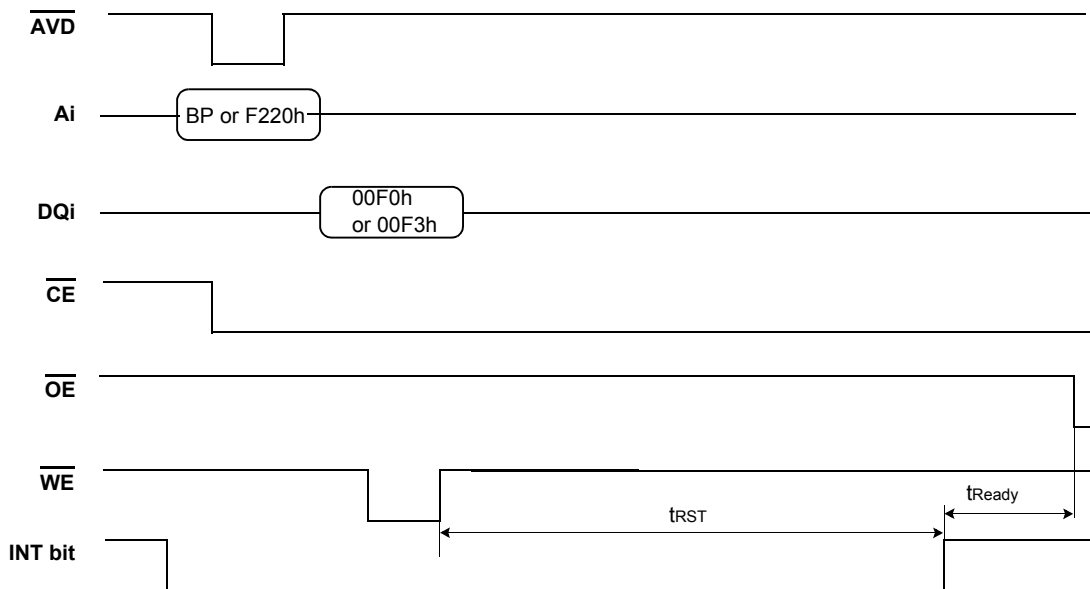

Figure 35. Reset Timing

**Performance**

Parameter	Symbol	Min	Typ	Max	Unit
Sector Load time (Note 1)	tRD1	-	40	45	μs
Page Load time (Note 1)	tRD2	-	85	100	μs
Sector Program time (Note 1)	tPGM1	-	320	720	μs
Page Program time (Note 1)	tPGM2	-	350	750	μs
OTP Access time(Note 1)	tOTP	-	600	1000	ns
Lock/Unlock/Lock-tight time (Note 1)	tLOCK	-	600	1000	ns
Number of Partial Program Cycles in the sector (Including main and spare area)	NOP	-	-	2	cycles
Block Erase time (Note 1)	tBERS1	-	2	3	ms

**NOTES:** These parameters are tested based on INT bit of interrupt register. Because the time on INT pin is related to the pull-up and pull-down resistor value. Please refer to page 73 and 74.

SWITCHING WAVEFORMS

Load Operations

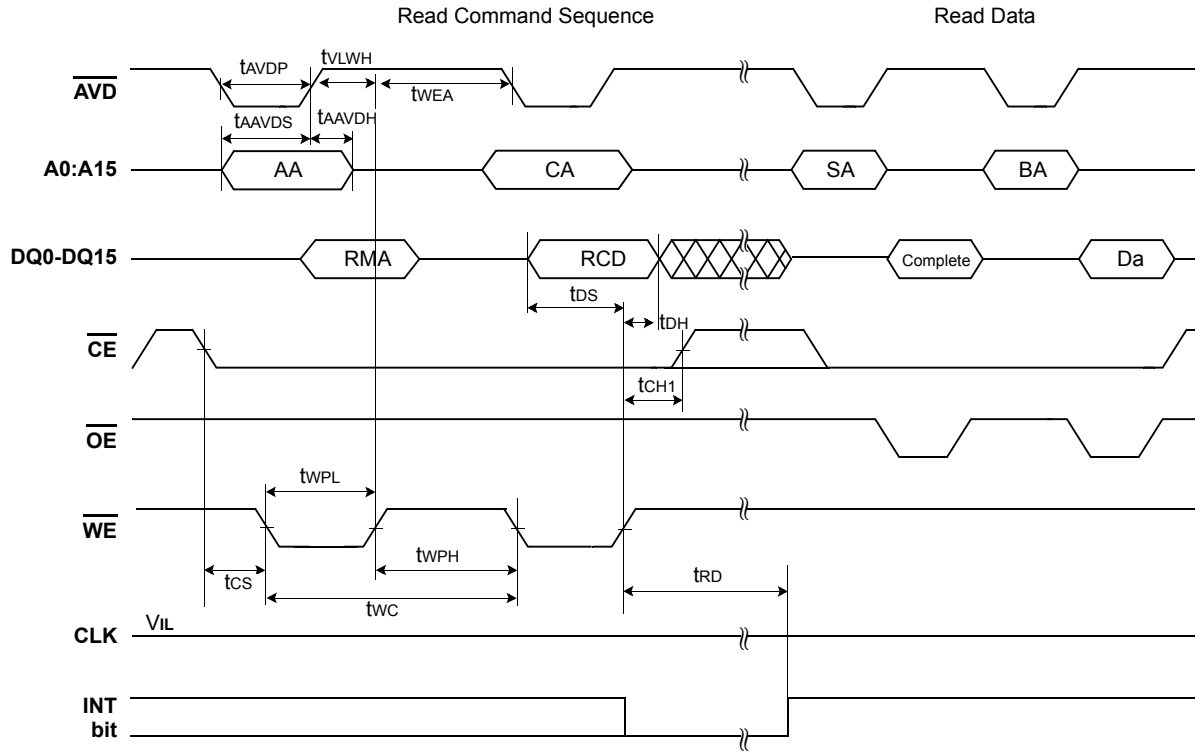

Figure 36. Load Operation Timing

NOTES:

1. AA = Address of address register  
 CA = Address of command register  
 RCD = Read Command  
 RMA = Address of memory to be read  
 BA = Address of BufferRAM to load the data  
 BD = Program Data  
 SA = Address of status register
2. "In progress" and "complete" refer to status register
3. Status reads in this figure is asynchronous read, but status read in synchronous mode is also supported.

SWITCHING WAVEFORMS

Program Operations

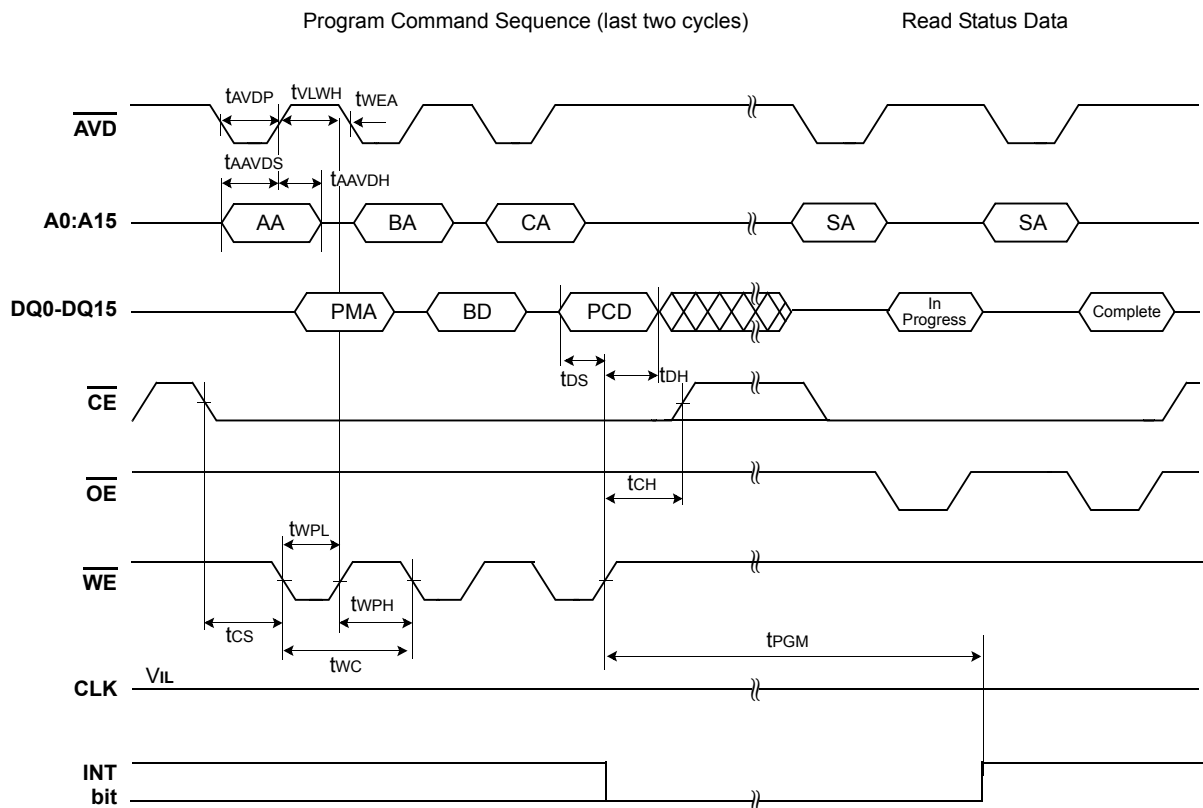

Figure 37 . Program Operation Timing

NOTES:

1. AA = Address of address register  
 CA = Address of command register  
 PCD = Program Command  
 PMA = Address of memory to be programmed  
 BA = Address of BufferRAM to load the data  
 BD = Program Data  
 SA = Address of status register
2. "In progress" and "complete" refer to status register
3. Status reads in this figure is asynchronous read, but status read in synchronous mode is also supported.

SWITCHING WAVEFORMS

Erase Operation

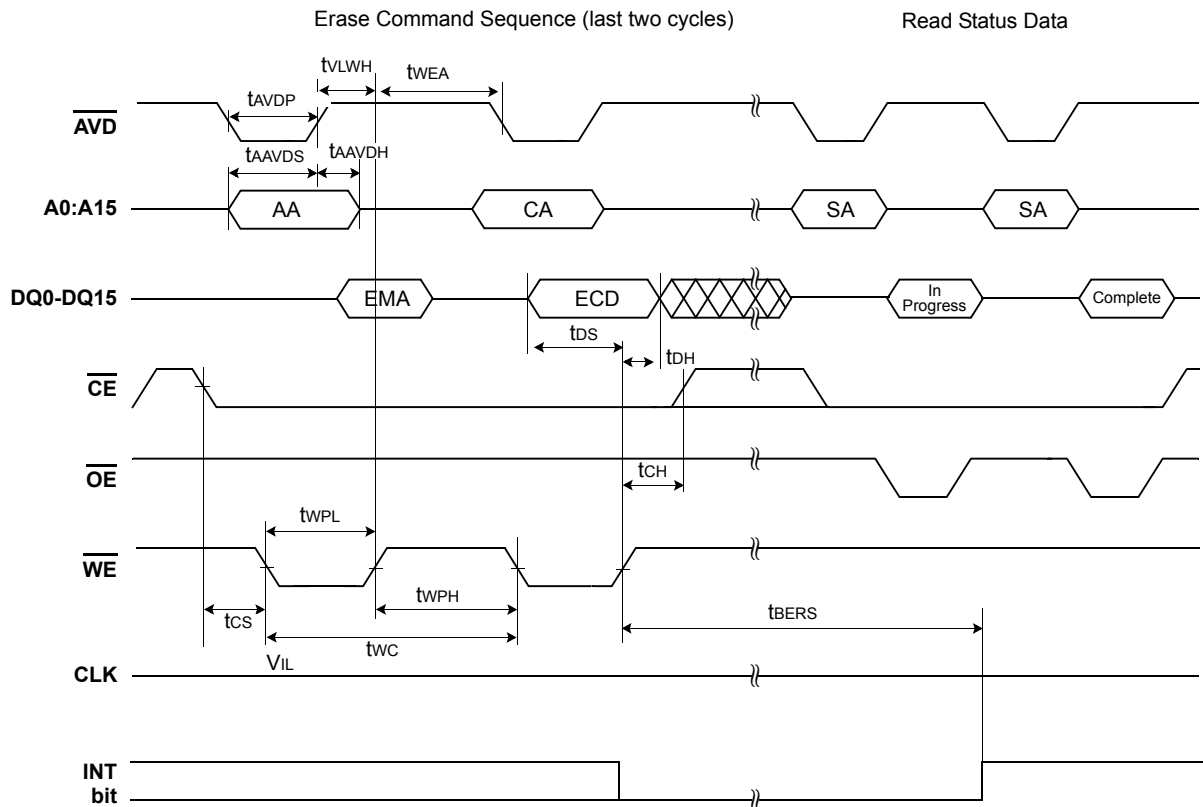
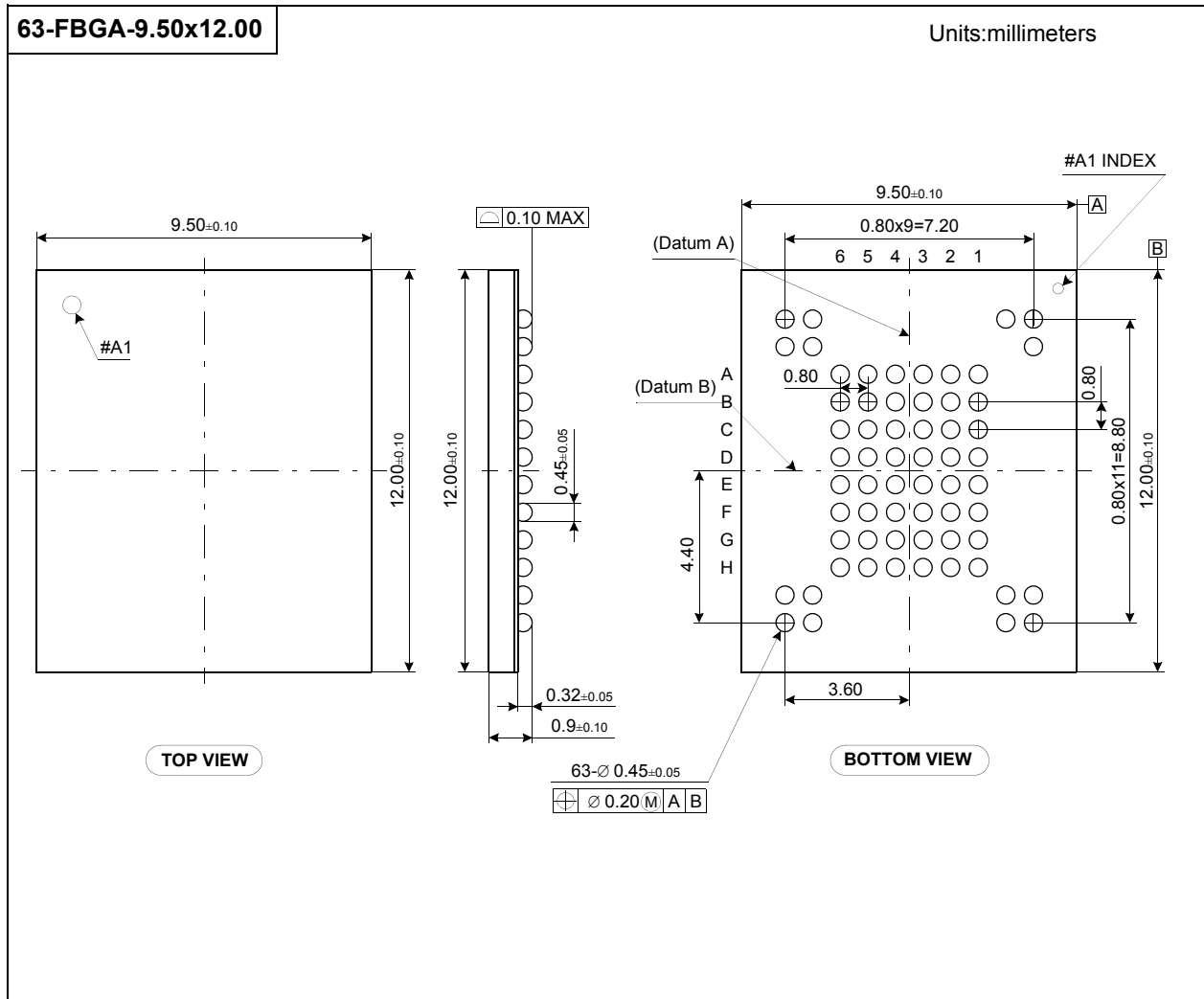

Figure 38. Block Erase Operations

NOTES:

1. AA = Address of address register  
 CA = Address of command register  
 ECD = Erase Command  
 EMA = Address of memory to be erased  
 SA = Address of status register
2. "In progress" and "complete" refer to status register
3. Status reads in this figure is asynchronous read, but status read in synchronous mode is also supported.

OneNAND512 PACKAGE DIMENSIONS



ORDERING INFORMATION

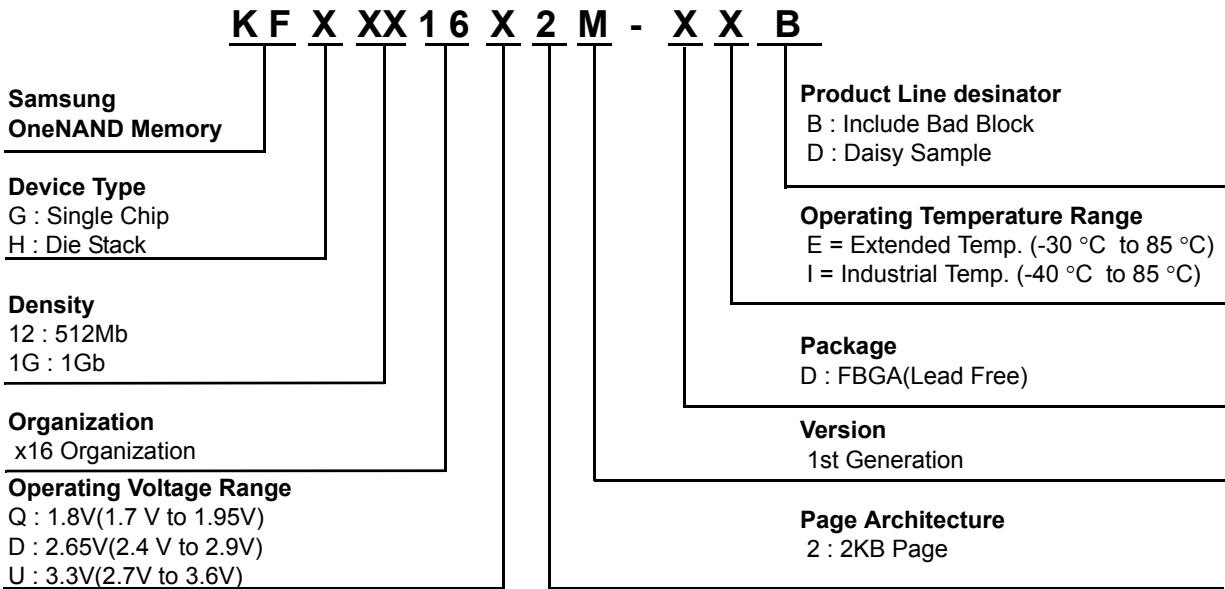

This datasheet has been downloaded from:

[www.DatasheetCatalog.com](http://www.DatasheetCatalog.com)

Datasheets for electronic components.