

HP DC ProCurve Switches 4000M and 8000M Installation Guide

Edition 1



Manufacturing Part Number: Z7017-90002

September 2001

© Copyright 2001 Hewlett-Packard Company

Notices

This document contains proprietary information which is protected by copyright. All rights are reserved. No part of this document may be photocopied, reproduced, or translated into another language without the prior written consent of Hewlett-Packard Company.

Disclaimer

The information contained in this document is subject to change without notice.

Hewlett-Packard assumes no responsibility for the use or reliability of its software on equipment that is not furnished by Hewlett-Packard.

HEWLETT-PACKARD MAKES NO WARRANTY OF ANY KIND WITH REGARD TO THE MATERIAL, INCLUDING, BUT NOT LIMITED TO THE IMPLIED WARRANTIES OF MERCHANTABILITY AND FITNESS FOR A PARTICULAR PURPOSE. Hewlett-Packard shall not be liable for errors contained herein or for incidental or consequential damages in connection with the furnishing, performance, or use of this material.

Trademarks

NEBS and Telcordia are trademarks of Telcordia Technologies Incorporated.

Molex is a trademark of Molex Incorporated.

Printing History

First Edition

October 2001

Preface

The HP DC ProCurve Switches provide DC power versions of the HP ProCurve 4000M and 8000M Switches for Central Office applications.

- Chapter 1 , “Overview,” on page 9 describes the HP DC ProCurve Switch features and ordering information.
- Chapter 2 , “Installing the Switch in a Seismic Rack,” on page 15 describes how to install the HP DC ProCurve Switch in a seismic rack.
- Chapter 3 , “Connecting the DC Power Supply,” on page 21 provides information for connecting DC power to the HP DC ProCurve Switch in a Central Office environment.
- Chapter 4 , “Replacing the DC Power Supply,” on page 31 provides information for replacing the HP DC ProCurve Switch DC power supply.
- Appendix A , “Specifications,” on page 35 provides specifications for the HP DC ProCurve Switch.
- Appendix B , “Regulatory Information,” on page 39 provides regulatory information for the DC power supply.

NOTE

See the *HP ProCurve Switch 4000M and 8000M Installation Guide* for information about switch features and operation, connecting network devices, connecting to a console, adding and replacing switch modules, and troubleshooting. See the *HP ProCurve Switch Modules Installation Guide* for information about the different switch modules.

This manual is intended for qualified service personnel to use in installing and servicing the HP DC ProCurve Switch.

Safety Information



Documentation reference symbol. If the product is marked with this symbol, refer to the product documentation to get more information about the product.

WARNING A WARNING in the manual denotes a hazard that can cause injury or death.

CAUTION A CAUTION in the manual denotes a hazard that can damage equipment.

Do not proceed beyond a WARNING or CAUTION until you have understood the hazardous conditions and have taken appropriate steps.

WARNING

This unit is intended for installation in a restricted access location, where access can only be gained by qualified service personnel. Such an area may be accessed only through the use of a special tool or a lock and key, or other means of security, and is controlled by the authority responsible for the location.

Contents

1. Overview

Introduction	10
Accessories and Ordering Information	11
Base Product - Z7017E 8000M	11
Options for 8000M	11
Base Product - Z7017F 4000M	12
Options for 4000M	12
Field Upgrades	12

2. Installing the Switch in a Seismic Rack

Introduction	16
Seismic Rack Kit	18
Installing the Switch in the Rack	19

3. Connecting the DC Power Supply

Introduction	22
Two Power Supplies	22
Connecting to the DC Power Source	23
Safety Grounding Procedures	26
Connecting the Power Supply	26
Troubleshooting	30

4. Replacing the DC Power Supply

Replacing the DC Power Supply	32
Removing the Power Supply	33
Installing the Power Supply	34

A. Specifications

Specifications	36
NEBS Compliance	36
Electrical	36
Environmental	37
Safety	37
EMC	38

B. Regulatory Information

Safety Information	40
EMC Regulatory Statements	41
U.S.A.	41
Canada	41
Europe	41
Australia/New Zealand	41

Contents

Japan	42
European Community	43

1 **Overview**

This chapter describes the HP DC ProCurve Switches.

Introduction

The HP DC ProCurve switches 4000M and 8000M are for the Central Office (CO) and other environments requiring DC powered NEBS compliant switches.

Some of the switch features are:

- Fully NEBS Level-3 compliant, including earthquake Zone-4.
- Power: -48 V or -60 V DC nominal, 8 amps maximum - typically 4 amps at -48 V DC fully loaded.
- Operates from a single power supply.
- An optional load-sharing second power supply provides redundant power when connected to an independent DC feed.
- Performance:
 - <10 μ s (LIFO) latency
 - 4.67 million pps throughput (64 Byte packets; 3.8 Gbps backplane)
 - Address table size: 10,000 entries
- Management:
 - SNMPv1/v2c
 - RMON groups 1 (stats), 2 (history), 3 (alarm), 9 MON
 - RFC 1493 Bridge MIB, RS-232C DB-9 local console port
 - extensive web-based network monitoring capability
- Rack mount kit available for HP Seismic Rack and HP non-seismic rack systems.

The DC 4000M and 8000M ProCurve products are the NEBS-compliant versions of the AC 4000M and 8000M products. Aside from the DC power supplies and optional seismic mounting hardware, the appearance, form factor, networking features and functionality of the DC versions of the products are the same as the AC versions.

Additional specifications and configuration information on the ProCurve family is available at www.hp.com/go/procurve.

Accessories and Ordering Information

Ordering basics:

- The base product may be ordered with no options.
- Multiples of options may be ordered for the base product.

Base Product - Z7017E 8000M

The 8000M ProCurve Switch with a single DC power supply includes the following parts.

- 8000M ProCurve Switch with no LAN modules installed
- DC Power supply (installed)
- Power Cable

Options for 8000M

- #opt 001, Redundant DC power supply
- #opt 002, Rack-mount kit for an HP Seismic Rack
- #opt 011, 10/100 Base-T Module (8-port RJ-45)
- #opt 012, Gigabit-SX Module (1-port SC optical)
- #opt 013, 100 Base-FX Module (4-port SC optical)
- #opt 014, Gigabit-LX Module (1-port SC optical)
- #opt 015, 100/1000 Base-T Module (1-port RJ-45)
- #opt 016, 10 Base-FL Module (4-port ST optical)

Base Product - Z7017F 4000M

The 4000M ProCurve Switch with a single DC power supply includes the following parts.

- 4000M ProCurve Switch with (5) 10/100 Base-T (8-port RJ-45) modules installed
- DC Power supply (installed)
- Power Cable

Options for 4000M

- #opt 001, Redundant DC power supply
- #opt 002, Rack-mount kit for an HP Seismic Rack
- #opt 011, 10/100 Base-T Module (8-port RJ-45)
- #opt 012, Gigabit-SX Module (1-port SC optical)
- #opt 013, 100 Base-FX Module (4-port SC optical)
- #opt 014, Gigabit-LX Module (1-port SC optical)
- #opt 015, 100/1000 Base-T Module (1-port RJ-45)
- #opt 016, 10 Base-FL Module (4-port ST optical)

Field Upgrades

The following field upgrades are available for either of the above products.

Z7017H, 10/100 Base-T Module (8-port RJ-45)

Z7017J, Gigabit SX Module (1-port) SC optical

Z7017K, 100 Base-FX Module (4-port SC optical)

Z7017L, Gigabit-LX Module (1-port SC optical)

Z7017M, 100/1000 Base-T Module (1-port RJ-45)

Z7017N, 10 Base-FL Module (4-port ST optical)

NOTE

The field upgrade products listed above are the only add-on modules supported for the DC ProCurve 4000M and 8000M products. They are functionally equivalent to the modules supported by the AC ProCurve 4000M and 8000M products

Overview

Accessories and Ordering Information

2 **Installing the Switch in a Seismic Rack**

This chapter describes how to install the HP DC ProCurve Switch in a seismic rack.

Introduction

NOTE

If the HP DC ProCurve Switch is already installed in a seismic rack, skip this chapter and go directly to Chapter 3 , “Connecting the DC Power Supply,” on page 21.

The HP DC ProCurve switch can be fitted with a seismic rack mount kit for installation in the HP Seismic Rack, or equivalent. This solution fulfills NEBS requirements for telecommunication equipment installed in a Central Office.

The steps for installing the HP DC ProCurve Switch are:

1. Attach switch to the tray.
2. Position the nut clips at the appropriate position on the rack mounting rails.
3. Secure the switch and seismic tray to the rack.

The mounting process may vary, depending on the type of rack or cabinet being used.

NOTE

See the *HP ProCurve Switch 4000M and 8000M Installation Guide* for alternate rack and cabinet installation solutions. Only the kit containing the Z7017-00001 rack mounting tray has been tested for NEBS compliance.

Seismic Rack Kit

The table below shows the parts included for this installation, and identification numbers for each component as it appears in Figure 2-1 on page 19.

Table 2-1 Earthquake Rack-Mount Components

ID Number	Description	Quantity	Part Number
1	Tray, ProCurve 8000, Seismic	1	Z7017-00001
2	Screw, M4x0.7x10 Pozi Flt Hd	8	0515-0913
3	Screw, M5x0.8x16 Torx Pan W/Lock	8	0515-0671
4	Nut-Clip, M5	8	0535-0093
5	Cable Tie, 8 inch	2	1400-0482

Installing the Switch in the Rack

- Step 1.** Attach the switch to the seismic tray **1** using eight (8) screws **2**.
- Step 2.** Position the eight (8) nut-clips **4** in the appropriate locations on the rack mounting rails.
- Step 3.** Secure the seismic tray in the rack using eight (8) screws **3** and the nut-clips installed in step 2.

Figure 2-1 Installing the Switch in the Seismic Rack

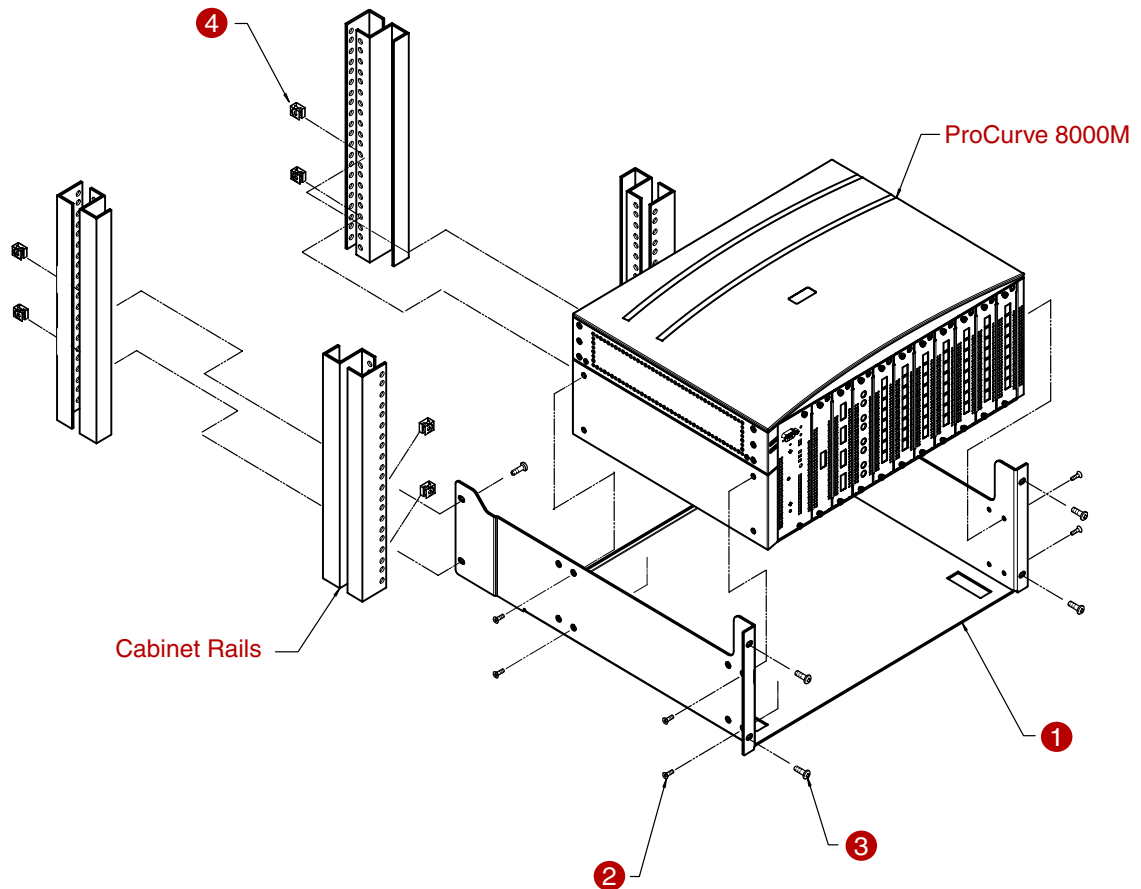

Installing the Switch in a Seismic Rack

Installing the Switch in the Rack

3 **Connecting the DC Power Supply**

This chapter provides information for connecting DC power to the HP DC ProCurve Switch in a Central Office environment.

Introduction

The DC power supplies are DC-to-DC converter modules, enabling the switch to be operated from centralized -48 or -60 V DC power sources.

Two Power Supplies

When two power supplies are installed, the DC power supplies have the following features:

- **Power load sharing -**
The two installed power supplies share the power load, which increases the life of both power supplies.
- **Power redundancy -**
If either power supplies fails, the remaining power supply provides enough power to continue running a fully loaded switch.
- **“Hot swap” operation -**
Either power supply can be replaced without shutting down or rebooting the switch.
- **Automatic fault detection -**
If the power supply encounters a problem, the switch can immediately detect the condition and report it, using the Power status and Fault LEDs on the switch. Event messages are also displayed in the Switch Console Event Log and the web browser interface Alert Log.

Connecting to the DC Power Source

CAUTION

Disconnect DC power from the power supply BEFORE installing or removing the supply. Not disconnecting the power first can damage the power supply or switch. Read this manual for proper handling procedures.

To avoid power supply or switch damage, do not attempt to power-up the power supply outside the switch chassis. The power supply requires a load and other enabling signals to operate properly.

WARNING

- 1.) The power supply cable is used as the main disconnect device for this equipment.**
 - 2.) Make sure that all Central Office safety precautions are carefully observed when connecting the power supply to the DC power source.**
 - 3.) This product is to be installed only in *Restricted Access Areas* (dedicated equipment rooms, equipment closets or the like) in accordance with Articles 110-16 to 110-18 of National Electrical Code, ANSI/NFFA 70.**
 - 4.) Installation should be performed only by qualified service personnel.**
-

Connecting the DC Power Supply

Connecting to the DC Power Source

The DC power supply has a rear panel-mounted 4-pin DC power connector. See Figure 3-1.

Figure 3-1 DC Power Rear Panel (with optional second power supply shown)

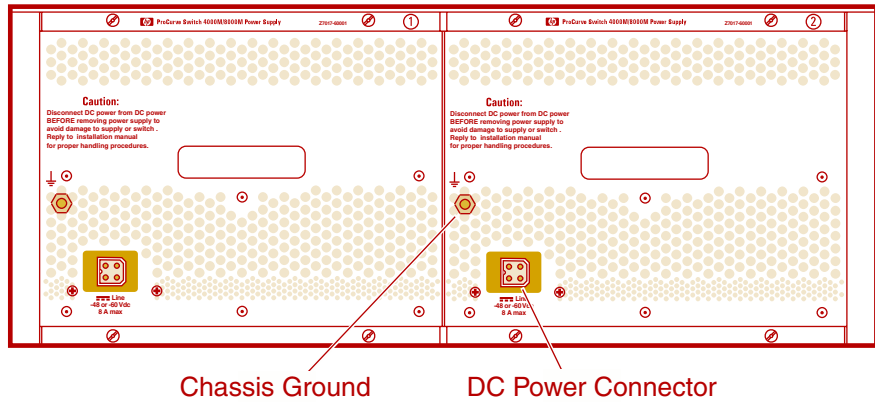

The unit has been supplied with a suitable power cable (Z7017-60006). See Table 3-1 and Figure 3-2 for the connector pinout details. The power cable must be connected to the rear panel-mounted 4-pin DC power connector and to the frame's fuse or circuit-breaker panel.

Table 3-1 DC Power Connector Pinouts and Cable Color Code

Function	Color	Pin No
-48V RTN	Black	4
-48V	Red	1
No Connection		2, 3

NOTE

To protect the equipment from overload or short circuits that can cause equipment damage or fire, the power supply has internal fuses. For added safety and integrity in the Central Office, the circuit which connects to the power supply should be protected with a 15 Amp over-current fuse or circuit breaker.

Figure 3-2 DC Power Pin Diagram

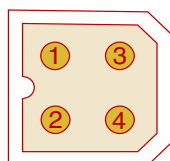

Power Supply
 (male pins)

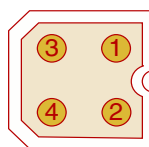

Cable (female pins)
 - Connector body Molex P/N 03-09-1049
 - Pins Molex P/N 02-09-1104

Safety Grounding Procedures

Each power supply has an M5 stud, starwasher, and nut on the rear panel for connecting to earth ground. Both power supplies should be connected to earth ground using a minimum 1.3 mm² (16 AWG) cable with a suitable Listed/Certified M5, or equivalent crimp-on ring terminal.

WARNING

This equipment must be connected to earth ground to assure continued safe operation, to prevent damage from electrostatic discharge, and to assure compliance with electromagnetic compatibility requirements.

Connecting the Power Supply

WARNING

Disconnect power from the source before connecting power to the product or before accessing the product's power terminals. The DC source can supply high levels of current capable of causing serious burns and arcing that can produce molten metal.

The steps required to connect the power supply are:

1. Connect the earth ground cable.
2. Connect the DC power cable.
3. Attach the cable strain relief.
4. Verify the power supply is installed correctly.

NOTE

For complete power redundancy, connect each power supply to a separate power source. This protects the system from power failure if one power source fails. Connecting both power supplies to the same power source protects the system if one power supply fails, but not from a failure in the power source.

Step 1. Use at least a 1.3mm² (16 AWG) earth ground cable with a crimp-on ring terminal.

Connect the earth ground cable to the grounding lug near the power connector on the face plate of the power supply.

Attach the cable to the grounding lug using the starwasher and nut provided.

The installation order for the connection is:

1. Ring terminal
2. Starwasher
3. Nut

Step 2. Connect the power cable from the DC source to the power connector.

Connecting the DC Power Supply

Connecting the Power Supply

Step 3. Attach a plastic tie wrap around the power cable and through the hole on the back of the rack mount tray to provide cable strain relief.

Pull the tie snug until the cable is securely attached and cut off the excess tie.

Figure 3-3

Connecting the Power Supply

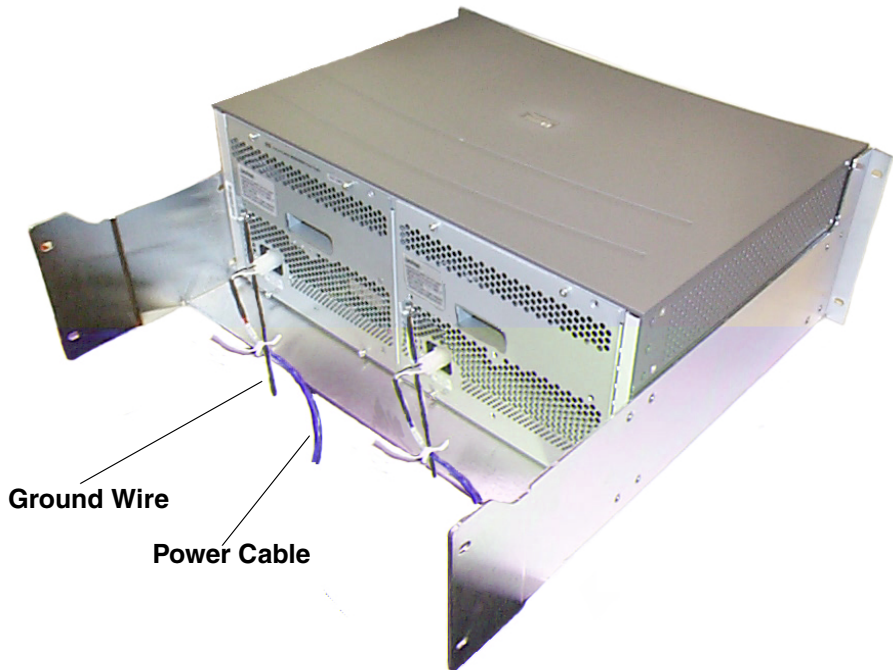

Step 4. Verify that the power supply is installed correctly by checking the LEDs on the Switch and the Switch Engine Module.

The Power Status LED should be on continuously and not flashing.

If the Power Status LED and the switch Fault LED are flashing, see the section “Troubleshooting” on page 30.

Figure 3-4 Power Status and Switch Fault LEDs

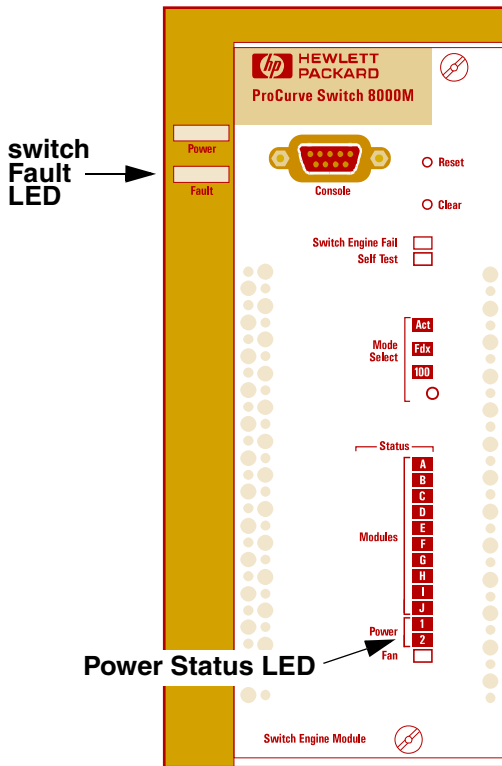

Troubleshooting

If the Power Status LED and the switch Fault LED are flashing, one of the following is probably occurring:

- The power supply is not connected to an active DC power supply
- The power supply is not properly installed
- A fault condition has been detected on the power supply.

To determine which condition exists, perform the following procedures:

1. Verify the power cable is connected to an active DC power source and to the power supply. Make sure these connections are tight.
2. Try unplugging the power cable and plugging it back in to the power supply.
3. If the Power Status LED continues to flash, verify the DC power source works.
4. If the previous steps do not solve the problem, try removing and reinstalling the power supply.

CAUTION

Disconnect DC power from the power supply **BEFORE** installing or removing the supply. Not disconnecting the power first can damage the power supply or switch. Read this manual for proper handling procedures.

To avoid power supply or switch damage, do not attempt to power-up the power supply outside the switch chassis. The power supply requires a load and other enabling signals to operate properly.

If the power source and power cable are operating and this condition persists, the switch power supply may be faulty.

4 Replacing the DC Power Supply

This chapter provides information for replacing the HP DC ProCurve Switch DC power supply.

Replacing the DC Power Supply

The DC power supply replacement steps are:

1. Disconnect the DC power.
2. Disconnect the earth ground.
3. Remove the installed power supply from the power supply slot.
4. Install the new power supply in the power supply slot in the back of the Switch.
5. Reconnect the earth ground.
6. Reconnect the DC power.
7. Verify that the power supply is installed correctly.

WARNING

Disconnect power from the source before connecting power to the product or before accessing the product's power terminals. The DC source can supply high levels of current capable of causing serious burns and arcing that can produce molten metal.

CAUTION

Disconnect DC power from the power supply BEFORE installing or removing the supply. Not disconnecting the power first can damage the power supply or switch. Read this manual for proper handling procedures.

To avoid power supply or switch damage, do not attempt to power-up the power supply outside the switch chassis. The power supply requires a load and other enabling signals to operate properly.

Removing the Power Supply

- Step 1.** Unplug the power cable from the power supply.
- Step 2.** Disconnect the ground cable from the grounding lug near the power connector on the face plate of the power supply.
- Step 3.** Use either a flat-bladed or Torx T-10 screwdriver and loosen the four captive screws connecting the existing power supply.
- Step 4.** Pull the power supply out of the opening, lifting it up while pulling.

Figure 4-1 **Removing the Power Supply from the Switch Chassis**

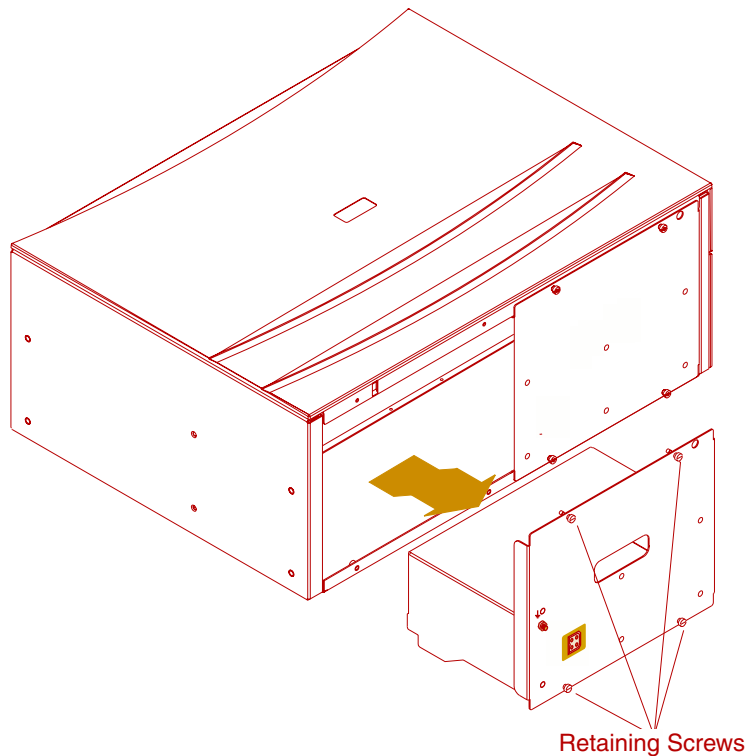

Replacing the DC Power Supply
Replacing the DC Power Supply

Installing the Power Supply

Step 1. Insert the power supply into the opening.

Lower it until it rests on the bottom of the switch chassis.

Slide it in until it connects to the connector at the back of the slot.

The power supply face plate should be flush with the back of the switch.

Step 2. Tighten the four retaining screws to hold the power supply in place as shown in Figure 4-2, “Installing the Power Supply into the Switch Chassis.”

The screws can be tightened with either a flat-bladed or Torx T-10 screwdriver. *Be careful not to overtighten the screws.*

Step 3. Go to Chapter , “Connecting the Power Supply,” on page 26 and follow the instructions on connecting the power supply to a DC power source.

Figure 4-2

Installing the Power Supply into the Switch Chassis

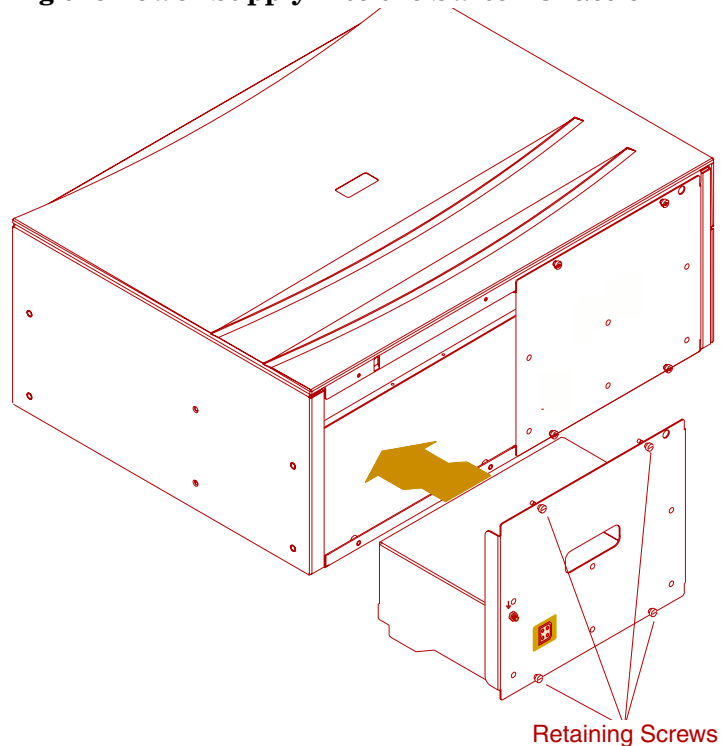

A **Specifications**

This Appendix provides specifications for the HP DC ProCurve Switch.

Specifications

IMPORTANT

Except as noted below, refer to the specifications provided in the *HP ProCurve Switch 4000M and 8000M Installation Guide*.

NEBS Compliance

The HP DC ProCurve Switch has been tested by an independent laboratory and found compliant with Telcordia (formerly Bellcore) NEBS *GR-63-CORE, Network Equipment-Building System (NEBS) Requirements: Physical Protection*; and *GR-1089-CORE, Electromagnetic Compatibility and Electrical Safety – Generic Criteria for Network Telecommunications Equipment*. NEBS compliance includes all “Level 3” criteria plus all applicable “Other Criteria” of Telcordia *SR-3580, Network Equipment-Building System (NEBS) Criteria Levels*.

NOTE

The HP DC ProCurve Switch is suitable for connection to intrabuilding or non-exposed wiring or cabling only. For compliance with NEBS lightning transient requirements, only shielded interface cables (STP) may be used and the cables must be grounded at both ends. For non-NEBS installations, unshielded twisted-pair (UTP) cables may be used.

Electrical

Nominal input voltage	-48 or -60 V DC
Input current:	8 A maximum, 4 A typical at -48 V DC
Input voltage range:	-36 to -72 V DC

Environmental

Temperature. From -60 to +4000 m (-197 to +13,123 ft.):

+5 to +40 °C continuous operation

-5 to +55 °C NEBS short-term operation

-40 to +70 °C storage and transportation

Relative Humidity, non-condensing:

5 to 85% R.H. at 40 °C continuous operation

90% R.H. at 28 °C short-term operation

95% R.H. at 40 °C storage and transportation

Earthquake:

NEBS Risk Zone 4

Heat Dissipation (according to GR-63-CORE)

Maximum heat release (based on 125 W operation)

305 mm (12 in.) rack	1080 W/m ² per meter of vertical rack space (31 W/ft ² per foot of vertical rack space)
----------------------	--

457 mm (18 in.) rack	702 W/m ² per meter of vertical rack space (20 W/ft ² per foot of vertical rack space)
----------------------	---

Forced-air cooling

Safety

NEBS GR-1089-CORE

UL 1950

CSA 950

EN60950 / IEC 950

Specifications
Specifications

EMC

NEBS GR-1089-CORE

FCC Part 15 Class A

ICES-003 Class A

EN 55022 / CISPR 22 Class A

EN 55024

VCCI Class A

AS/NZS 3548 Class A

B **Regulatory Information**

This appendix provides regulatory information for the HP DC ProCurve Switch.

Safety Information

See Section C, Safety and EMC Regulatory Statements, in the *HP ProCurve Switch 4000M and 8000M Installation Guide* for multilingual safety information.

EMC Regulatory Statements

The following EMC regulatory statements apply to the HP DC ProCurve Switch.

U.S.A.

FCC Class A

This equipment has been tested and found to comply with the limits for a Class A digital device, pursuant to Part 15 of the FCC Rules. These limits are designed to provide reasonable protection against interference when the equipment is operated in a commercial environment. This equipment generates, uses, and can radiate radio frequency energy and, if not installed and used in accordance with the instruction manual, may cause interference to radio communications. Operation of this equipment in a residential area may cause interference, in which case, the user will be required to correct the interference at his own expense.

Canada

This Class A digital apparatus meets all requirements of the Canadian Interference-Causing Equipment Regulations.

Cet appareil numérique de la classe A respecte toutes les exigences du Règlement sur le matériel brouilleur du Canada.

Europe

This is a Class A product. In a domestic environment this product may cause radio interference, in which case, the user may be required to take adequate measures.

Australia/New Zealand



N279

This product complies with Australia/New Zealand EMC Class A requirements.

Regulatory Information
EMC Regulatory Statements

Japan

VCCI Class A

この装置は、情報処理装置等電波障害自主規制協議会（VCCI）の基準に基づくクラスA情報技術装置です。この装置を家庭環境で使用すると電波妨害を引き起こすことがあります。この場合には使用者が適切な対策を講ずるよう要求されることがあります。

European Community

DECLARATION OF CONFORMITY according to ISO/IEC Guide 22 and EN 45014

Manufacturer's name: Hewlett-Packard Company

Manufacturer's address: 19420 Homestead Road
Cupertino, California 95014
USA

declares that the product:

Product name: HP DC ProCurve Switch 4000M, 8000M, and 8000M/RDC

Model number: Z7017Y, where Y can be any letter A through Z.

Product Options: All

conforms to the following Product Specifications:

Safety: IEC 60950:1991+A1+A2+A3+A4
EN 60950:1992+A1+A2+A3+A4+A11

EMC: CISPR 22:1997 / EN 55022:1998
CISPR 24:1997 / EN 55024:1998

Supplementary Information:

The product herewith complies with the requirements of the Low Voltage Directive 73/23/EEC and the EMC Directive 89/336/EEC and carries the CE-marking accordingly. LEDs in this product are Class 1 in accordance with EN 60825-1:1994.

Note: The product was tested in a typical configuration with various Hewlett-Packard LAN modules.

Cupertino, CA
September 2001

Office of the Quality Manager

European contact for regulatory topics only: Hewlett-Packard GmbH, HQ-TRE, Herrenberger
Straße 130, D-71034 Böblingen (FAX: +49-7031-14-3143)

Regulatory Information
EMC Regulatory Statements



HEWLETT®
PACKARD

Order Part Number
Z7017-90002
E0100

Printed in USA



Z7017-90002
Manufacturing Part Number