



**FPDM**

---

---

# ***FLAT PANEL DISPLAY MEASUREMENTS STANDARD***

***Version 1.0***

---

---

## **VESA**

**VIDEO ELECTRONICS STANDARDS ASSOCIATION**

Flat Panel Display Interface Committee

Flat Panel Display Measurements Standard Working Group

*Abstract: This is a standard to provide measurement procedures to quantify flat panel display characteristics. Performance criteria or performance minima are not specified; rather, a series of measurements are clearly detailed to enable unambiguous and reproducible measurements of displays using the simplest instrumentation that will provide adequate results. All measurements need not be performed. The measurements that are most applicable to the display purposes can be selected as desired. Diagnostics and metrological difficulties are addressed, and technical discussions are presented to assist those unfamiliar with light measurements.*

May 15, 1998

*Printing: June 9, 1998*





## VESA

VIDEO ELECTRONICS STANDARDS ASSOCIATION  
Flat Panel Display Interface Committee  
Flat Panel Display Measurements Standard Working Group

---

# ***FLAT PANEL DISPLAY MEASUREMENTS STANDARD***

## ***Version 1.0***

---

**Intellectual Property:** Copyright © 1998, Video Electronics Standards Association. All rights reserved. Some measurements described in this standard can permanently affect the performance of the display or even destroy the display. While every precaution has been taken in the preparation of this standard, the Video Electronics Standards Association and its contributors assume no responsibility for errors or omissions, and make no warranties, expressed or implied, of functionality or suitability for any purpose.

**Trademarks:** All trademarks used in this document are property of their respective owners. VESA is a registered trademark of the Video Electronics Standards Association.

**Patents:** VESA proposals and standards are adopted by the Video Electronics Standards Association without regard to whether their adoption may involve any patents or articles, materials, or processes. Such adoption does not assume any liability to any patent owner, nor does it assume any obligation whatever to parties adopting the proposals or standards documents.

**Support:** Clarifications and application notes to support this standard may be written. To obtain the latest standard and any support documentation, contact VESA.

If you have a product that incorporates *FPDM*, you should ask the company that manufactured your product for assistance. If you are a manufacturer, VESA can assist you with any clarification you may require. All comments or reported errors should be submitted in writing to VESA using one of the following methods:

- Fax 408-435-8225, *direct this note to Technical Support at VESA*
- e-mail support@vesa.org
- mail to Technical Support  
VESA - Video Electronics Standards Association  
2150 North First Street, Suite 440  
San Jose, CA 94513-2029



# TABLE OF CONTENTS

TABLE OF CONTENTS .....	iii
<b>100 INTRODUCTION AND OVERVIEW .....</b>	<b>1</b>
<b>200 REPORTING.....</b>	<b>5</b>
<b>300 OPTICAL MEASUREMENTS —PHOTOMETRY AND COLORIMETRY .....</b>	<b>11</b>
<b>*301 SETUP OF DISPLAY AND EQUIPMENT .....</b>	<b>19</b>
301-1 MEASUREMENT EQUIPMENT.....	20
301-2 MEASUREMENT AND DISPLAY CONDITIONS .....	22
301-3 DISPLAY SETUP AND INITIAL TESTING.....	33
<b>302 CENTER MEASUREMENTS OF FULL SCREEN.....</b>	<b>39</b>
*302-1 LUMINANCE AND COLOR OF FULL-SCREEN WHITE.....	40
*302-2 LUMINANCE AND COLOR OF FULL-SCREEN BLACK .....	41
*302-3 CONTRAST RATIO OF FULL SCREEN .....	42
*302-4 GAMUT AND COLORS OF FULL SCREEN .....	43
*302-5 GRAY SCALE OF FULL SCREEN .....	44
302-6 COLOR SCALES OF FULL SCREEN.....	47
302-7 FULL-SCREEN GRAY-SCALE COLOR CHANGES.....	48
302-8 LUMINANCE ADJUSTMENT RANGE.....	49
302-9 LUMINOUS FLUX.....	50
<b>303 DETAIL, RESOLUTION, AND ARTIFACTS.....</b>	<b>52</b>
303-1 LINE LUMINANCE AND CONTRAST.....	53
303-2 $N \times N$ GRILLE LUMINANCE AND CONTRAST.....	55
303-3 PIXEL FILL FACTOR.....	57
*303-4 SHADOWING (GRAY-SCALE ARTIFACTS).....	59
303-5 INTRACHARACTER LUMINANCE AND CONTRAST .....	61
303-6 DEFECTIVE PIXEL ANALYSIS .....	63
303-7 RESOLUTION FROM CONTRAST MODULATION .....	70
<b>304 BOX-PATTERN MEASUREMENTS .....</b>	<b>72</b>
304-1 LUMINANCE & CONTRAST OF CENTERED BOX.....	73
304-2 CENTERED BOX ON-OFF LUMINANCE & CONTRAST .....	75
304-3 TRANSVERSE CONTRAST OF CENTERED BOX .....	76
304-4 GRAY SCALE OF CENTERED BOX.....	77
304-5 COLOR GAMUT OF CENTERED BOX .....	78
304-6 COLOR SCALES OF CENTERED BOX.....	78
304-7 HALATION.....	79
304-8 LUMINANCE LOADING .....	80
*304-9 CHECKERBOARD LUMINANCE & CONTRAST ( $n \times m$ ).....	81
<b>305 TEMPORAL PERFORMANCE .....</b>	<b>83</b>
*305-1 RESPONSE TIME.....	84
305-2 RESIDUAL IMAGE .....	87
305-3 WARM-UP-TIME MEASUREMENT.....	89
305-4 DOMINANT FLICKER COMPONENT .....	91
305-5 FLICKER MODULATION AMPLITUDE.....	93
<b>306 UNIFORMITY.....</b>	<b>95</b>
*306-1 SAMPLED UNIFORMITY & COLOR OF WHITE .....	98
*306-2 SAMPLED UNIFORMITY OF BLACK.....	100
*306-3 SAMPLED UNIFORMITY OF CONTRAST RATIO.....	101
306-4 SAMPLED UNIFORMITY OF COLORS .....	102

306-5	SAMPLED UNIFORMITY OF DARK GRAY .....	103
*306-6	ANOMALOUS NONUNIFORMITY.....	104
<b>307</b>	<b>VIEWING ANGLE PERFORMANCE.....</b>	<b>105</b>
*307-1	FOUR-POINT VIEWING ANGLE.....	106
307-2	THRESHOLD-BASED H&V VIEWING ANGLES.....	107
307-3	GRAY-SCALE INVERSION .....	109
307-4	VIEWING-CONE THRESHOLDS.....	111
307-5	GRAY-SCALE INVERSION VIEWING CONE .....	113
<b>308</b>	<b>REFLECTION.....</b>	<b>115</b>
308-1	REFLECTANCE WITH DIFFUSE ILLUMINATION.....	117
*308-2	AMBIENT CONTRAST RATIO.....	119
308-3	LARGE-SOURCE DIFFUSE REFLECTANCE.....	122
308-4	LARGE-SOURCE SPECULAR REFLECTANCE.....	126
308-5	SMALL-SOURCE SPECULAR REFLECTANCE .....	129
<b>400</b>	<b>ELECTRICAL PERFORMANCE.....</b>	<b>133</b>
<b>401</b>	<b>POWER CONSUMPTION &amp; SUPPLY .....</b>	<b>134</b>
*401-1	POWER CONSUMPTION.....	135
401-2	POWER SUPPLY RANGE VERIFICATION.....	139
<b>402</b>	<b>EFFICIENCIES .....</b>	<b>141</b>
*402-1	FRONTAL LUMINANCE EFFICIENCY – $e$ .....	142
402-2	LUMINOUS EFFICACY – $h$ .....	143
<b>500</b>	<b>MECHANICAL AND PHYSICAL CHARACTERISTICS .....</b>	<b>145</b>
<b>501</b>	<b>SIZE OF DISPLAY .....</b>	<b>146</b>
501-1	SIZE OF VIEWABLE AREA .....	147
501-2	ASPECT RATIO.....	151
<b>502</b>	<b>STRENGTH.....</b>	<b>153</b>
502-1	TORSIONAL STRENGTH .....	153
502-2	FRONT-OF-SCREEN STRENGTH .....	155
<b>APPENDIX.....</b>		<b>156</b>
<b>A100</b>	<b>METROLOGY.....</b>	<b>157</b>
A101	VEILING GLARE AND LENS FLARE ERRORS.....	158
A102	SPATIAL INVARIANCE AND INTEGRATION TIMES .....	167
A103	LIGHT MEASUREMENT DEVICES.....	173
A104	SIGNALS, COLORS, AND PATTERN GENERATION .....	176
A105	ADEQUACY OF SINGLE MEASUREMENTS .....	177
A106	DETECTOR LINEARITY DIAGNOSTICS .....	178
A107	POLARIZATION EFFECTS DIAGNOSTICS .....	179
A108	UNCERTAINTY EVALUATIONS .....	180
A109	COLOR MEASUREMENT DIAGNOSTICS.....	184
A110	TEMPORAL RESPONSE DIAGNOSTICS .....	186
A111	ARRAY DETECTOR MEASUREMENTS.....	187
A112	IMAGES AND PATTERNS FOR PROCEDURES .....	189
A113	AUXILIARY LABORATORY EQUIPMENT .....	194
A114	HARSH ENVIRONMENT TESTING .....	197
A115	ESTABLISHMENT OF PERPENDICULAR.....	198
<b>A200</b>	<b>TECHNICAL DISCUSSIONS.....</b>	<b>201</b>
A201	PHOTOMETRY AND COLORIMETRY SUMMARY .....	201
A202	POINT SOURCE, CANDELA, SOLID ANGLE, $I(\mathbf{q}, \mathbf{f})$ , $E(r)$ .....	210
A203	LUMINANCE - $L(z)$ FOR DIFFUSE OBJECT .....	211
A204	SPOTLIGHT VS. ANGLE - $\cos(\theta)$ .....	213
A205	GLOWWORM & DETECTOR, $I(\mathbf{q}, \mathbf{f})$ , $J=kF$ .....	213
A206	PROPERTIES OF A LAMBERTIAN SURFACE .....	214

A207	UNIFORM COLLIMATED FLASHLIGHT.....	216
A208	HEADLIGHT (DIVERGENT UNIFORM FLASHLIGHT) .....	217
A209	NONLINEAR RESPONSE OF EYE.....	219
A210	$E(z)$ FROM EXIT PORT OF INTEGRATING SPHERE.....	220
A211	EXIT PORT ILLUMINATION OF DIFFUSE SURFACE.....	221
A212	INTEGRATING SPHERE INTERIOR - $L$ & $E$ .....	222
A213	LENS $\cos^4(\theta)$ VIGNETTE.....	223
A214	ILLUMINANCE FROM LUMINANCE .....	224
A215	ILLUMINANCE INSIDE AN INTEGRATING SPHERE.....	224
A216	REFLECTION FROM ROOM WALLS ONTO SCREEN.....	225
A217	REFLECTION MODELS .....	227
A218	DIGITAL FILTERING BY MOVING WINDOW AVERAGE .....	235
A219	COLLIMATED OPTICS .....	237
A220	MEASURES OF CONTRAST—A TUTORIAL .....	238
A221	STATEMENTS OF UNCERTAINTY .....	243
A222	PROCEDURE FOR VERIFYING DIGITALLY DRIVEN COLOR MONITORS.....	246
A223	LUMINANCE OF AN LED .....	249
A224	LUMINANCE OF LAMBERTIAN DISPLAY.....	249
A225	GAIN OF A DISPLAY.....	250
A226	EQUIPMENT BASED ON FOURIER OPTICS .....	251
<b>A300</b>	<b>GLOSSARY, DEFINITIONS, ETC.....</b>	<b>254</b>
<b>A400</b>	<b>REFERENCES.....</b>	<b>268</b>
<b>A500</b>	<b>TABLES AND FORMULAS.....</b>	<b>271</b>

\* Refers to measurements and setup procedures that are part of the Suite of Basic Measurements (SBM) and the associated SBM Report Form. See Section 200 (Reporting).

This page was intentionally left blank.



# 100 INTRODUCTION AND OVERVIEW

**Introduction:** Most who will use this document will go to the measurement procedure sections directly and get to work or may be interested in the discussions of measurement problems in the Metrology Section (A100). If you are a beginner in photometry and colorimetry, you may wish to review a number of subsections in the Technical Discussions Section (A200) in the Appendix to get a better understanding of the difficult concepts employed and the units of measuring light. A summary of the more important tables presented in this document are found in the Appendix under Tables of Note (A500). However, we especially want to call your attention to the Reporting Section (200). There you will find a template called the “VESA Suite of Basic Measurements.” The Suite of Basic Measurements (SBM) is a small set of important measurements that are selected from all the measurements contained in this document. See the Reporting Section (200) for a complete discussion. The SBM Report Form is a one-page report (two sides) for the measurements in the SBM. We hope you will find the template useful and easy to use with the procedures. The measurements that are a part of the SBM are marked with the icon at the right.



*Suite of Basic  
Measurements.*

**NOTE:** The word “screen” is used throughout this document to mean the active visible area that produces video information—often called the **viewable area** of the screen or display. The **diagonal** of the screen refers only to the diagonal measure of the viewable area of the screen, assumed to be rectangular. The term “diagonal” may not be used to refer to parts of the surface of the display that either don’t contain image producing pixels or are covered by a bezel in normal operation of the display.

**Scope and Extension:** This standard is a measurement standard, not a compliance standard, nor a prescription for calibration or adjustment of displays. We are trying to describe good metrology for characterizing flat panel displays (FPDs). What people do with the results is their own business, but we wanted to make sure that it was measured correctly. The goal of a measurement standard is to provide unambiguous methods so that everybody would get the same results on the same display. Another goal of this standard is to make robust measurements as simple as possible for the widest variety of equipment. A final goal of this standard is to establish conventions of naming and reporting parameters that characterize the screen, such as “diagonal,” maximum imprecision of a reported diagonal measurement, aspect ratio definition and the maximum imprecision of a reported aspect ratio, etc.

Ultimately, this standard will be extended so that it can be used for all display types. However, at this time we are focusing our attention on emissive or transmissive **color displays** that would be used for the workplace, in a laptop computer, or the equivalent. These are often called **direct-view** displays that don’t depend upon ambient light as do reflective or transreflective displays. It is left to the user to adapt these methods to other displays as appropriate. For example, **monochrome** displays based on luminance contrast would be accommodated by avoiding the color-based measurements, whereas monochrome displays based on color contrast would employ the color measurements and might avoid the luminance-based measurements. Also, **reflective** and **transreflective** displays would require the specification of an ambient light configuration before these methods could be applied. In the future we intend to add more procedures as users demand them, e.g., to accommodate projection displays, head-mounted displays, head-up displays, stereoscopic displays, and CRT displays. This is not a static document. More procedures will be added as they become fully tested. If a procedure is not in this document and you think it should be included, feel free to contact the chair or vice chair listed below. Some procedures may be less reliable than others, or they have not been fully tested. Such procedures are clearly marked as tentative or preliminary. They were included for the sake of completeness. They will be appropriately refined in later versions. On the VESA web site ([www.vesa.org](http://www.vesa.org) in directory /pub/fpdm) we will maintain a publicly accessible **update file FPDMUPDT.PDF** (Adobe’s Portable Document Format®) that documents any known errors, omissions, updates, and comments of substance regarding the current version. In a document of this magnitude, there are bound to be errors, improvements, etc. The maintenance and availability of this file assures that users of this document will have the latest information.

**Buffet:** The thinking behind this document is simple: The user may select the measurements that are most important to characterize the display for its intended use—like selecting food items from a buffet—and may ignore

uninteresting measurements. In other words, you don't need to use all the procedures listed in this document. Select the ones you want, or use the ones agreed upon by all interested parties. There may be different ways to characterize the same thing, such as measuring contrast under different conditions. Each measurement is a separate procedure by itself with a unique name and a clear identification.

**Format and Special Content:** We have spent considerable time attempting to outline sources of errors in measurements. We have included diagnostics to detect some of the problems in the measurement equipment, and we have included a rather extensive discussion on good metrology in the Metrology Section in the appendix (A100). The appendix also contains a Technical Discussions Section (A200) for tutorial information. We have also tried to make the document easy to use and to read. We have deliberately avoided the very difficult and awkward numbering system found in most standards documents (a system for which  $3.9 < 3.10$  and where the strings of numbers and periods can reach annoying lengths and be hard to remember). The numbering system used is designed to be easy to remember and follow as you move through the document. Each measurement is complete and self contained. People who are making these measurements are not interested in the frustration of thumbing back-and-forth through many pages to find out what is needed. To simplify the procedure sections and to make them easy to read for the experienced user, much of the explanatory information has migrated to the appendix—either to the Metrology or Technical Sections. We have used icons to remind the user quickly of commonly repeated setup conditions (found in 301 Setup of Display and Equipment). Icons are also used as section dividers to provide a graphical environment for finding one's way around the document. Measurement procedures that are part of the Suite of Basic Measurements are marked with an "SBM" icon for quick reference (see below in Section 200).

Usually, each procedure is divided into several sections: The name of the measurement heads the page followed by any alternate names where applicable, a DESCRIPTION section briefly identifies the measurement, the units and any symbols used, and sometimes a definition or explanation. The SETUP section details any conditions peculiar to the measurement and icons are used to remind the user of general setup conditions. The PROCEDURE section describes the steps to be taken. An ANALYSIS section describes any calculations or processing of the data that may be needed. The REPORTING section shows how the data might be reported on a report sheet. Finally, a COMMENT section discusses any anticipated problems, cautions, or irregularities. In many cases a means to quantify the uncertainty in the measurement or determination will be found in the comments section. Often, when a simple luminance measurement is made, for example, the uncertainty in the measurement is the same as the uncertainty in the instrumentation.

**Sample Data, Examples, and Example Configurations:** Throughout this document we present sample data, examples, and apparatus configurations to make the material clear. The values and arrangements shown do not necessarily represent the best values or even typical values. The apparatus configurations shown are also not necessarily the best to use, or preferable. We have attempted to allow a wide variety of equipment to make measurements on displays with a wide variety of characteristics. Our examples serve for illustration purposes only. The formats of the reporting examples, etc. are simply guidelines for your reference.

**Exceptions and Deviations:** With many of the procedures listed here there may be reason to deviate from the described measurement procedures. If this is ever the case, it is imperative that all interested parties (manufacturer, integrators, and users) agree to any negotiated changes or modifications. For example, the sampled uniformity measurement calls for measurements at five or optionally nine places on the screen. If all interested parties agree to 25 points at other locations, then this should be clearly indicated in any reporting documentation. We have avoided being restrictive and narrow minded. We have attempted to make an adaptable document. However, please note: *To claim that a measurement made on a display is compliant with this document must include making any departures, deviations, or exceptions very clear to all interested parties in any reporting document, reporting method, and advertisement.*

**Patterns, Report, and Update Files:** Files to be displayed on the screen, used in reporting, or keeping this document up-to-date are available from VESA for several uses: setup, SBM, report form, and all the measurements contained in this document. These can be downloaded from

<b>Files Available to the Public.</b> www.vesa.org under directory /pub/FPDM See INDEX.TXT for descriptions of available files.	
FPDMSU*.*	Used for setting up the display.
FPDMSBM.*	Used for the Suite of Basic Measurements (SBM).
FPDMALL.*	Used for all the measurements contained in this document.
FPDMRF*.*	Report Forms (for SBM and others as available).
FPDMUPDT.PDF	Update on the current version of this document

[www.vesa.org](http://www.vesa.org) under directory /pub/FPDM—see the table. The asterisk refers to the file type. We again draw your attention to the **FPDMUPDT.PDF** (Adobe's Portable Document Format®). It contains all the **latest information** regarding the current release of this document. Any errors, omissions, comments, changes, etc. will be placed in this file so you can be assured of the most recent consensus of those who participate (including users) in the development of this document.

**Acknowledgements:** We want to thank the Electronics Industries Association of Japan (EIAJ) for providing us their standard for flat panel display measurements. We are especially grateful to Dr. Shigehiko Satoh for his help and valuable input in sharing all the research that went into the EIAJ as well as translating the document into English and making the translation available to us. Many of the methods employed by the EIAJ are deliberately reproduced here (with permission) so that international uniformity and consistency can be maintained. We also would like to thank the International Standards Organization (ISO: TC159/SC4/WG2) for similarly providing information from the standards they are developing. We have also tried to be consistent with the methods within the ISO performance standards as much as possible. We finally want to thank Mark Williamson formerly of NIST for starting this group and Dr. Dennis Bechis of NIDL for taking the ball and running with it as its first chair. We also want to thank the VESA staff for all their assistance with the preparation of the document, the wonderful working lunches, the electronic mail and file handling over the internet, and the pleasant surroundings for our meetings.

Edward F. Kelley, Chair  
NIST (National Institute of Standards and Technology, formerly NBS)  
301-975-3842, kelley@eeel.nist.gov

Michael D. Grote, Vice Chair  
NIDL (National Information Display Laboratory)  
609-734-2506, mgrote@sarnoff.com

**WORKING GROUP MEMBERS:** (those who endured a long time, met with the working group within the last six months of the end of the first release, or contributed greatly)

Dennis Bechis, NIDL, 609-734-2845, dbechis@sarnoff.com  
Michael Becker, autronic-Melchers, (49)-721-96264 45, becker-michael@t-online.de  
Michael H. Brill, NIDL, 609-734-3037, mbrill@sarnoff.com  
Paul Boynton, NIST, 301-975-3014, boynton@eeel.nist.gov  
Jean Noël Curt, ELDIM, 33-31 94 76 00, eldim@msn.com  
Manjit Daniel, Photo Research, 818-341-5151, manjitd@photoresearch.com  
Bruce Denning, Microvision, 408-658-0363, microvsn@redshift.com  
Phillip Downen, Westar, 314-298-8748 x274,downen@westar.com  
Mike Grote, NIDL, 609-734-2506, mike\_grote@maca.sarnoff.com  
Sal Ghalya, TUV Rheinland, 510-734-8100 x107, ghalya@tuv.com  
Bill Grenawalt, OCLI, 707-525-7243, William\_Grenawalt@ocli.com  
George Jones, NIST, 301-975-4225, jones@eeel.nist.gov  
Edward F. Kelley, NIST, 301-975-3842, kelley@eeel.nist.gov  
Tom Kwan, Minolta, 805-250-0776, tkwon@minolta.com  
Hector Lara, Photo Research, 818-341-5151, hectorl@photoresearch.com  
Thierry Leroux, ELDIM, 33-31 94 76 00, eldim@msn.com  
Max Lindfors, Fujitsu, +358 9 569 6716, max.lindfors@fujitsu.fi  
Mackey, Bob, Candescant Tech., 408-360-2646, bmackey@candescant.com  
Mike Marentic, Hitachi America, 408-436-3402, fpdmike@best.com  
Joe Miseli, Sun Microsystems, 415-786-6577, jvm@heyjoe.eng.sun.com  
Mark Parish, OCLI, 707-525-7038, mparish@ocli.com  
Cecil Penn, Motorola, 602-413-7153, afp033@email.mot.com  
James Rancourt, OCLI, 707-525-7642, jrancourt@ocli.com  
John Roberts, NIST, 301-975-5683, roberts@cmr.ncsl.nist.gov

Shigehiko Satoh, NEC Electronics, Inc. 408-588-6851, shigehiko\_satoh@el.nec.com  
 Dan Schinasi, Minolta Corp., dschinasi@minolta.com  
 Kingo Takahashi, NEC Electronics, 415-965-6136, ktakahas@el.nec.com  
 Osamu Tomita, Toshiba America Electronic Components, 408-965-4200, Osamu\_Tomita@taec.toshiba.com  
 Wayne (Noriyoshi) Uenishi, Hosiden, 408-252-0541, hoaco.ca2cs@applelink.apple.com  
 William Vu, Toshiba, 714-587-3898, williamv@tais.com  
 John Wilson, Allied Signal, John.C.Wilson@alliedsignal.com  
 Peter Wojtowicz, Consultant to NIDL, 609-924-2027

A number of VESA members have met or corresponded with the working group, and we thank them for their contributions: Tom Fiske, dpiX; Macedonio Anaya, Boeing; Dell Bleiler; Chris Hogh; Erwin Dreiske and Walter Rim, Unisys; Bob Thorkildson, Rockwell (and SAE); Hyeog Sang Shin, Samsung; Nikola Vidovich, Hitachi; Tom Dolash, Battelle; Tom Lippert, formerly of NIDL; Selina Sun, formerly of Apple.

A special thanks goes to Yoshi Ohno, NIST, who, although not involved directly with the working group, took the time to review the entirety of this document, undertook the difficult task of checking the calculations and photometric methods, assisted with technical matters, and even offered written suggestions that were included with this document (and would therefore be considered a contributing author). We would also like to thank Barry Taylor, NIST, who assisted us in expressing uncertainty estimations and approved notation.

#### **AUTHOR CONTRIBUTION LIST:**

The entire working group made valuable contributions throughout the document. We list here the greater efforts.

#### **100 INTRODUCTION**

EFK (P)

#### **200. REPORTING**

Joe Miseli (P), EFK

#### **300. OPTICAL**

300 EFK (P), Cecil Penn, Tom Fiske

301 Joe Miseli (P), EFK (P),  
 Sal Ghalya, Thierry Leroux,  
 Mike Grote, Osamu Tomita,  
 Noriyoshi Uenishi

302-1-6, 9 EFK (P)

302-7 EFK (P), Joe Miseli

302-8 Joe Miseli (P), Mike Grote

303-1-3, 5, EFK (P), Mike Grote,  
 Joe Miseli, Osamu Tomita,  
 Noriyoshi Uenishi

303-4 Joe Miseli (P), Osamu Tomita,  
 Noriyoshi Uenishi, EFK

303-6 Joe Miseli (P), EFK (P), Bruce  
 Denning, Sal Ghalya

303-7 Mike Grote (P)

304-1-6, 9 EFK (P)

304-7, 8 EFK (P), Mike Grote

305-1 Bruce Denning (P), Mike  
 Brill, Osamu Tomita, Noriyoshi  
 Uenishi

305-2 Joe Miseli (P), EFK

305-3 EFK (P), Mike Grote, Mike  
 Brill

305-4 Bruce Denning (P), Mike Brill

305-5 Joe Miseli (P), Mike Brill

306 EFK (P)

306-1-6 EFK (P), Mike Brill

307-1-5 Mike Grote (P), Mike Brill,  
 Osamu Tomita, Noriyoshi

Uenishi

308-1-6 EFK (P), Bill Grenawalt,  
 Max Lindfors

#### **400 ELECTRICAL**

401-1, 2 Joe Miseli (P)

402-1, 2 EFK (P), Joe Miseli

#### **500 MECHANICAL**

501-1 Joe Miseli (P), EFK (P),  
 Osamu Tomita, Noriyoshi  
 Uenishi

501-2 Joe Miseli (P), Osamu Tomita,  
 Noriyoshi Uenishi, Mike Brill,  
 EFK

502-1, 2 Joe Miseli (P)

#### **A100 METROLOGY**

A101, 2,4,5, 11-15, 21, 23 EFK (P)

A103 EFK (P), Thierry Leroux,  
 Bruce Denning

A106 George Jones (P), EFK

A107 Paul Boynton (P), EFK

A108 EFK (P), Max Lindfors

A109 Paul Boynton (P), Hector Lara,  
 Mike Brill, EFK

A110 George Jones (P), EFK

#### **A200 TECHNICAL DISCUSSIONS**

A201 Manjit Daniel (P), Mike  
 Brill (P), EFK

A202-8, 10-12, 14-17, 23-25, 27  
 EFK (P)

A209 Mike Brill (P), EFK

A213 EFK (P), Mike Brill

A218, 19 Bruce Denning (P)

A220 Mike Brill (P), James  
 Rancourt

A222 Mike Brill (P)

A226 Thierry Leroux (P)

---

*P = a primary author*

*EFK = Ed Kelley (editor)*

## 200 REPORTING

### SUITE OF BASIC MEASUREMENTS:

There are a number of measurements that seem fundamental—some of the first characteristics people look for when they consider displays. This collection of measurements is called the Suite of Basic Measurements (SBM). The selected measurements are listed in the table below. Any measurement in the SBM is marked with the icon at the right. The Suite of Basic Measurements Report Form on the following pages provides a template to record these measurements. This report-form template is available from the VESA world-wide-web site ([www.vesa.org](http://www.vesa.org)). The name of the files will be FPDMMRF.???, where ??? is the file type. By supplying this form we do not require its use for the purposes of this standard. It is merely an example and we hope you find it useful. An example of how the form might be filled out follows the form—this is only an example. You may want to add items to a form or to use your own form. In fact, many measurements specified in this document are not a part of the SBM. In most cases we give examples in the measurement procedure of how the measurement might be reported on an appropriate form you might create. Associated with the SBM is a computer file (FPDMSBM.??? see below) containing the appropriate patterns to be used should the display being measured interface with a computer or is provided with a computer.



### SUITE OF BASIC MEASUREMENTS REPORT FORM:

On the next two pages is a two-sided template for reporting results that has places for entering all the information gathered by means of our Suite of Basic Measurements. The Suite of Basic Measurement Report Sheet has two sides. The header information is provided also on the second page. If the report sheet is made with both pages on a single sheet, it may not be necessary to fill out the header information, depending upon how the sheet is used. If the sheet will ever have single sided copies made of its content, then the header information should be filled out on both pages so that the DUT (display under test), at the very least, is properly identified along with its data. The shaded regions of the form are either optional or non-measured values. The following procedures are included:

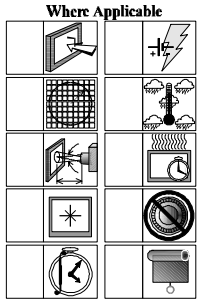
SUITE OF BASIC MEASUREMENTS (not in order)					
Procedure	Section	Page	Procedure	Section	Page
<b>Setup</b>	301	19	<b>Response Time</b>	305-1	84
<b>Full-Screen Center Meas.</b>	302	39	<b>Uniformity (Sampled)</b>	306	95
FS White	302-1	40	White	306-1	98
FS Black	302-2	41	Black	306-2	100
FS Contrast Ratio	302-3	42	Contrast Ratio	306-3	101
FS Gamut and Colors	302-4	43	Anomalous Nonuniformity (optional)	306-4	104
FS Gray Scale	302-5	44	<b>Power Consumption</b>	401-1	135
<b>Shadowing</b>	303-4	59	<b>Frontal Luminance Efficiency</b>	402-1	142
<b>Viewing Angle</b>	307-1	106	<b>Checkerboard Contrast</b> (optional)	304-9	81
<b>Ambient Contrast</b>	308-2	109			

### PATTERNS FOR THE SUITE OF BASIC MEASUREMENTS:

The appropriate patterns for the Suite of Basic Measurements can be obtained from the VESA world-wide-web site at address [www.vesa.org](http://www.vesa.org). Download the appropriate file with name FPDMSBM.??? where ??? is the file type: "PPT" for Microsoft's PowerPoint® used on a PC (personal computer), "PDF" for Adobe's Portable Document Format® where Adobe's reader is also available from the web site ([www.adobe.com](http://www.adobe.com)) for any platform, etc. The general characteristics of these files and examples are described in the Metrology Section under Images and Patterns for Procedures (A112). Further discussion of their use will be found in that section. These files can also be obtained directly using FTP (file transfer protocol) from [ftp.vesa.org](ftp://ftp.vesa.org) with anonymous logon within the /pub/fpdm directory.

# DIRECT-VIEW FPD DATA RECORD — SUITE OF BASIC MEASUREMENTS

**DISPLAY INFO:** Manufacturer: \_\_\_\_\_ Model No: \_\_\_\_\_ Serial No: \_\_\_\_\_ Rev. Level: \_\_\_\_\_  
**DESCRIPTION:** Diagonal Size: \_\_\_\_\_ Pixels: \_\_\_\_\_ (hor) × \_\_\_\_\_ (ver) Technology: \_\_\_\_\_ Configuration: \_\_\_\_\_  
**PITCH:** Horizontal: Pixel: \_\_\_\_\_ Subpixel (Dot): \_\_\_\_\_ Other: \_\_\_\_\_ Measurement Direction: \_\_\_\_\_  
 Vertical: Pixel: \_\_\_\_\_ Subpixel (Dot): \_\_\_\_\_ Other: \_\_\_\_\_ Location of Center Meas.: \_\_\_\_\_  
**COLORS:** Bits/color: \_\_\_\_\_ Color bits: \_\_\_\_\_ Gray Levels: \_\_\_\_\_ Total Colors: \_\_\_\_\_ Signal Source: \_\_\_\_\_ Power Source: \_\_\_\_\_  
**SIZE:** Active Area: \_\_\_\_\_ (hor) × \_\_\_\_\_ (ver) LMD: Make \_\_\_\_\_ Model \_\_\_\_\_ Serial No \_\_\_\_\_ Distance \_\_\_\_\_ AFOV \_\_\_\_\_  
**OVERALL:** Dimensions: \_\_\_\_\_ (hor) × \_\_\_\_\_ (ver) Depth: \_\_\_\_\_ Mass (weight): \_\_\_\_\_ Design Viewing Direction: \_\_\_\_\_  
**Test Person:** \_\_\_\_\_ **Date:** \_\_\_\_\_ **Warm-Up Time:** \_\_\_\_\_ min **Temperature:** \_\_\_\_\_ °C **Run:** \_\_\_\_\_ **Page 1/2**

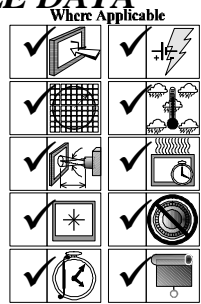


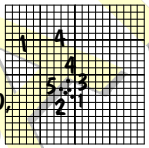
Full-Screen Center (302-1...4)				Uniformity: Nonuniformity = 100% x [1-(Min/Max)] or Δu'v' (306-1,2,3,6)										Power Consumption (401-1)				Frontal Lum. Eff. (402-1)				
	L cd/m <sup>2</sup>	x	y	9 pt	5 pt	L <sub>w</sub>	L <sub>b</sub>	C <sub>U</sub>	x <sub>w</sub>	y <sub>w</sub>	u' <sub>w</sub> *	v' <sub>w</sub> *	CCT	Supply	Volts	I(A)	(W)	Pattern:	White Full Screen			
White				1	1									High				Voltage	V <sub>dc/ac(rms)</sub>			
Black				2										<b>Panel</b>				Current	A <sub>dc/ac(rms)</sub>			
C <sub>R</sub>		No Units for C <sub>R</sub>		3	2									Low				Power, P	W <sub>dc/ac(rms)</sub>			
Red				4										High				L <sub>w</sub>	cd/m <sup>2</sup>			
Green				5	3									<b>Inverter</b>				e=L <sub>w</sub> /P	cd/m <sup>2</sup> W			
Blue				6										Low				<b>Checkerboard Con. (304-9)</b>				
<b>Full-Screen Gray Scale (302-5)</b>				7	4									High				Pattern n×m	×			
Level	L cd/m <sup>2</sup>	Opt-16	L cd/m <sup>2</sup>	8										<b>Other</b>				L <sub>w</sub>	L <sub>b</sub>			
Wht-7		Wht-15		9	5									Low				C <sub>c</sub>				
6	14			Ave.					Max					Pattern Used: ↓		High	<b>Response Time (305-1)</b>					
5	13			Min.				Δu'v'									<b>TOTAL</b>	Blk-Wht	ms			
4	12			Max.				↓									Low	Wht-Blk	ms			
3	11			Nonunif.												<b>Ambient Contrast (308-2)</b>			Total	ms		
2	10			An. Low											White L <sub>AW</sub>	L <sub>w</sub>	L <sub>b</sub>	L' <sub>w</sub>	L' <sub>b</sub>			
1	9			An. High										Black L <sub>AB</sub>	L <sub>aw</sub>	L <sub>ab</sub>	L <sub>std</sub>	ρ <sub>std</sub>				
Bck-0	8			An. Non.					Anomalous Δu'v'					C <sub>A</sub>	E		E <sub>L</sub>					
Gamma				<b>Viewing Angle (307-1 or 2)</b>		White			Black			Red			Green			Blue				
<b>Shad.=100% L<sub>box</sub>-L<sub>bkg</sub> /L<sub>bkg</sub> (303-4)</b>				Direct'n	Angle	L <sub>w</sub>	x <sub>w</sub>	y <sub>w</sub>	CCT(K)	L <sub>b</sub>	x <sub>b</sub>	y <sub>b</sub>	C <sub>R</sub>	L <sub>red</sub>	x <sub>red</sub>	y <sub>red</sub>	L <sub>grn</sub>	x <sub>grn</sub>	y <sub>grn</sub>	L <sub>blu</sub>	x <sub>blu</sub>	y <sub>blu</sub>
Box at (A-E)		Lum. (cd/m <sup>2</sup> )		Up	q <sub>U</sub>																	
Box (0-7)		L <sub>box</sub>		Dwn	q <sub>D</sub>																	
Bkgnd. (0-7)		L <sub>bkg</sub>		Right	q <sub>R</sub>																	
Shadowing %				Left	q <sub>L</sub>																	
Comments:																			*u' = 4x/(3+12y-2x) v' = 9y/(3+12y-2x)			



# DIRECT-VIEW FPD DATA RECORD—SUITE OF BASIC MEASUREMENTS — SAMPLE DATA

DISPLAY INFO: Manufacturer: Whatever Co Model No: B119 Serial No: 123456 Rev. Level: A  
 DESCRIPTION: Diagonal Size: 12.1 (307 mm) Pixels: 1204 (hor) × 768 (ver) Technology: AM-TFT-LCD Configuration: Laptop  
 PITCH: Horizontal: Pixel: 240.1um/px Subpixel (Dot): DPI=105.8 Other: \_\_\_\_\_ Measurement Direction: Perpendicular  
 Vertical Pixel: 240.1um /px Subpixel (Dot): \_\_\_\_\_ Other: \_\_\_\_\_ Location of Center Meas.: Center  
 COLORS: Bits/color: 6R,6G,6B Color bits: 18 Gray Levels: 64 Total Colors: 262 144 Signal Source: internal Power Source: internal  
 SIZE: Active Area: 245.9 mm (hor) × 184.4 mm (ver) LMD: Make Wower Optics Model 123 Serial No 12345 Distance: 500 mm AFOV 2°  
 OVERALL: Dimensions: 295 mm (hor) × 220 mm (ver) Depth: 12.2 mm Mass (weight): 0.621 kg Design Viewing Direction: Perpendicular 12 o clock  
 Test Person: Al ert Date: 8/24/97 Warm-Up Time: 22 min Temperature: 21.2 °C Run: 1 Page ½

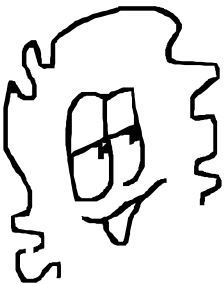


Full-Screen Center (302-1...4)				Uniformity: Nonuniformity = 100% x [1-(Min/Max)] or Δu'v' (306-1...4)										Power Consumption (401-1)				Frontal Lum. Eff. (402-1)				
	L cd/m <sup>2</sup>	x	y	9 pt	5 pt	L <sub>w</sub>	L <sub>b</sub>	C <sub>U</sub>	x <sub>w</sub>	y <sub>w</sub>	u'w *	v'w *	CCT	Supply	Volts	I(A)	(W)	Pattern:	White Full Screen			
White	96.2	0.277	0.285	1	1	109	1.02	107	0.250	0.650	0.097	0.568	6838	High	5.50	0.523	2.88	Voltage	5.00, 12.0 V <sub>dc/ac</sub> (rms)			
Black	0.411	0.247	0.242	2										Panel	5.00	0.507	2.54	Current	.425, 603 A <sub>dc/ac</sub> (rms)			
C <sub>R</sub>	234	No Units for C <sub>R</sub>		3	2	87.8	0.91	96.5	0.235	0.690	0.087	0.574	6968	Low	.450	0.467	2.10	Power, P	9.36 W <sub>dc/ac</sub> (rms)			
Red	28.9	0.594	0.319	4										High	12.5	0.628	7.85	L <sub>w</sub>	97.8 cd/m <sup>2</sup>			
Green	48.1	0.299	0.606	5	3	115	1.05	110	0.250	0.700	0.092	0.578	6700	Inverter	12.0	0.602	7.22	e=L <sub>w</sub> /P	10.5 cd/m <sup>2</sup> W			
Blue	19.3	0.145	0.068	6										Low	11.5	0.571	6.57	Checkerboard Con. (304-9)				
Full-Screen Gray Scale (302-5)				7	4	75.1	2.15	34.9	0.262	0.765	0.090	0.591	6396	High					Pattern n×m	6 × 6		
Level	L cd/m <sup>2</sup>	Opt-16	L cd/m <sup>2</sup>	8										Other				L <sub>w</sub>	98.2	L <sub>b</sub>	0.43	
Wht-7	106	Wht-15		9	5	97.3	1.53	63.6	0.225	0.722	0.080	0.579	7027	Low				C <sub>C</sub>	228			
6	81.3	14		Ave.		96.8	1.33	82.4	Max Δu'v' ↓ (0.0, 0.5)				6786	Pattern Used: ↓	High	10.73	Response Time (305-1)					
5	55.6	13		Min.		75.1	0.91	34.9					6396	Single-Pixel Checker board	TOTAL	9.76	Blk-Wht	17	ms			
4	33.6	12		Max.		115	2.15	110					7027		Low	8.67	Wht-Blk	23	ms			
3	17.4	11		Nonunif.		35	58	68					0.024	8.9	Ambient Contrast (308-2)			Total	40	ms		
2	7.14	10		An. Low	125									White L <sub>AW</sub>		L <sub>w</sub>		L <sub>b</sub>		L'w	L'b	
1	1.68	9		An. High	55.3									Black L <sub>AB</sub>		L <sub>aw</sub>		L <sub>ab</sub>		L <sub>std</sub>	β <sub>std</sub>	
Bck-0	0.084	8		An. Non.	56				Anomalous Δu'v'					C <sub>A</sub>		E		E <sub>L</sub>				
Gamma	2.17			Viewing Angle (307-1 or 2)		White			Black			Red			Green			Blue				
Shad.=100% L <sub>box</sub> -L <sub>bkg</sub>  /L <sub>bkg</sub> (303-4)				Direct'n	Angle	L <sub>w</sub>	x <sub>w</sub>	y <sub>w</sub>	CCT(K)	L <sub>b</sub>	x <sub>b</sub>	y <sub>b</sub>	C <sub>R</sub>	L <sub>red</sub>	x <sub>red</sub>	y <sub>red</sub>	L <sub>grn</sub>	x <sub>grn</sub>	y <sub>grn</sub>	L <sub>blu</sub>	x <sub>blu</sub>	y <sub>blu</sub>
Box at (A-E)	0	Lum. (cd/m <sup>2</sup> )	95.0	Up q <sub>U</sub>	15°	85.6	0.298	0.322		1.59	0.271	0.292	52.9	25.9	0.521	0.350	50.2	0.296	0.521	16.1	0.157	0.140
Box (0-7)	0	L <sub>box</sub>	95.0	Dwn q <sub>D</sub>	10°	111	0.322	0.348		3.79	0.269	0.285	29.2	35.4	0.520	0.349	63.5	0.305	0.518	20.3	0.166	0.165
Bkgnd. (0-7)	7	L <sub>bkg</sub>	103	Right q <sub>R</sub>	30°	39.4	0.323	0.346		0.553	0.268	0.290	71.2	12.1	0.550	0.354	22.5	0.307	0.541	6.23	0.158	0.150
Shadowing %	7.8			Left q <sub>L</sub>	30°	39.9	0.323	0.345		0.609	0.270	0.297	65.4	12.3	0.548	0.353	22.7	0.306	0.540	6.34	0.158	0.150
Comments: During warm-up it was noted that the displa looks mottled , it is not ver uni orm to the e e, ut it is pro a l small enough to escape the measurements o uni ormit .																			*u' = 4x/(3+12y-2x)			
Anomalous nonuni ormit ot spot in upper le t uadrant, dark spot in lower le t uadrant.																			v' = 9y/(3+12y-2x)			



This page was intentionally left without important technical information content.

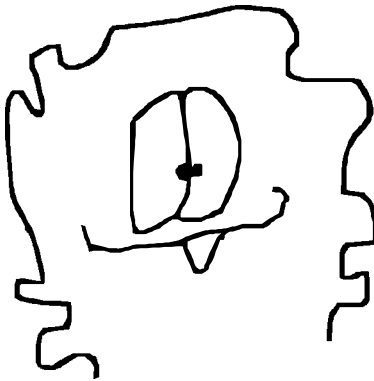
Well, doesn't that depend upon what you call important?



Good point! I think it's important to know the page is blank.



But the page isn't blank!



Well, then, why don't we define a blank page in the glossary?!!

Now do you see why this got so big?!



# 300 OPTICAL MEASUREMENTS — PHOTOMETRY AND COLORIMETRY

## 300-1 GENERAL REMARKS

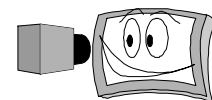
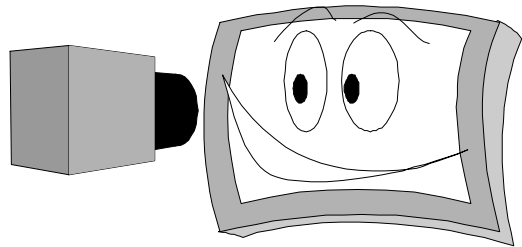
A number of general statements need to be made to provide the proper orientation for the users of this document. We have specified several items that may distinguish this document from others.

**NOTE:** The word “screen” is used throughout this document to mean the active visible area that produces video information—often called the **viewable area** of the screen or display. The **diagonal** of the screen refers only to the diagonal measure of the viewable area of the screen, assumed to be rectangular. The term “diagonal” must only refer to parts of the surface of the display that contain image-producing elements such as active pixels for a pixelated display. The diagonal may not include any pixels (or imaging-producing regions) covered by a bezel, mask, or surrounding border not involved in producing video information.

**Exceptions and Deviations:** Any deviations from the procedures stated in this document must be clearly stated in any reporting document. Many displays may be designed for wide-angle viewing. However, there may be specialty displays constructed for a particular task. For example, some displays may be designed only for perpendicular (normal) viewing, and hence would need only perpendicular measurements. Some displays are designed for viewing from a direction other than perpendicular. Displays may also be designed for viewing from a specific viewing point a certain distance from the display surface. Usually the measurement method can be readily adapted to accommodate such a display. However, we require that any change in procedure be clearly stated in any reporting documentation and that all involved negotiating parties agree with the changes and how they are reported.

**Setup of Display:** We call your attention to the setup section: Display Setup and Initial Testing (301-3). How the DUT (display under test) is configured can be very important. Once the DUT has been properly configured to accommodate the task for which it was designed or the task for which it is being used, the controls should not be changed for all the rest of the measurements. This avoids the problem of optimizing the controls in a way in which the display would not be used in order to improve the results of each measurement. *Note: If you are interested in making measurements for which the display must be turned off or controls changed, then it is advisable to make those measurements before you make the final setting of the controls. Alternatively, perform these measurements as the last to be made. This includes 302-8 Luminance Adjustment Range and the reflection measurements in 308.* The goal of the setup is to measure the DUT as it will be used. If the manufacturer doesn't specify how the DUT should be configured, there are images and targets available from VESA that will assist in the adjustment of the controls for the intended use (see 301-3a for a detailed description of their use and A111 for their construction and content). During the warm up of the DUT prescribed in the setup section (301-3) a number of subjective visual observations can be made and recorded.

**Similar Measurements:** The center measurements of full screen and of a centered box employ the same setup conditions (sections 303 and 304). Once you have setup the DUT, equipment, and positioned the DUT for center measurements, you can proceed with a number of other full-screen or box center measurements directly. Knowing this may save a little time so that you don't have to read each section in its entirety thinking that some detail may be hidden in the text, except for the color of the screen (white, black, colors) or the size of the area displayed (full screen or a box) the arrangement of equipment is the same. The viewpoint of this document has been that each measurement be separate and complete in itself. This can lead to some unavoidable redundancy in the measurement procedures.

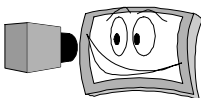


**Full Screen Contrast:** Some will note that we call for the full-screen contrast ratio in this document as representing the contrast capabilities of the DUT. For some display types (e.g. projection displays) this is not the best choice to characterize contrast. Some object to the use of full-screen contrast because the DUT is not being measured under conditions of normal use. The argument is that a small black square on a white screen or a black letter on a white screen is a much better indicator of screen contrast. We are willing to grant that such a claim may be accurate from an ergonomic point of view especially for cases where there are large white areas (or equivalent) on the screen. However, our observations are that many people have trouble accurately measuring black luminances when there are nearby white areas present on the screen unless due care is taken. See the Metrology Section under Veiling Glare and Lens-Flare Errors (A101). We have opted to provide a measurement that is simple and reproducible by using full-screen white and black to determine the overall contrast ratio. Other contrast measurement methods are described, and can always be employed as well provided they are properly identified. There may be displays that appear to have infinite contrast. This case is very rare if proper setup conditions are employed or if the light-measuring device (LMD) has sufficient sensitivity, see 301-3a Adjustment of Display Controls for more information. Again, the attention to full-screen contrast is focused at direct-view displays at this time.

We acknowledge that contrast may not be the best metric to use, but it is traditional and deeply ingrained in the display community. A metric something like the cube root of the contrast ratio would perhaps be more indicative of how the eye appreciates contrast—a ratio of  $L^*$  values (see A201, Photometry and Colorimetry Summary). Any appropriate contrast metric may be employed in addition, provided it is agreeable to all interested parties and is clearly indicated in any reporting documentation.

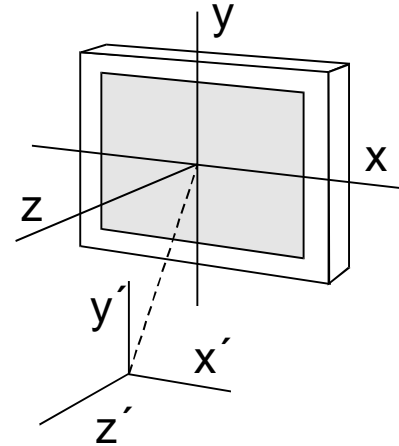
**Single Measurement:** Some will object to the absence of multiple measurements of each quantity where many feel that the mean and standard deviation of several measurements should be reported. Our thinking on this is described in the Metrology Section under Adequacy of Single Measurements (A105), and a verification criterion is described in Luminance Measurement Repeatability (301-2k). Briefly, photometry and colorimetry are sciences for which the repeatability of the measurement usually is much smaller than the uncertainty of measurement. Single measurements are adequate if they are verified as having a repeatability that is small compared to the uncertainty of measurement. Each measurement system and each DUT should be tested to assure that single measurements are, indeed, adequate (using 301-2k—Luminance Measurement Repeatability).

**Notation:** In this document we use the 1931 CIE ( $x, y$ ) chromaticity coordinates since they are very commonly used elsewhere. If you prefer some other chromaticity coordinate system, feel free to use whatever system you want. We especially recommend the ( $u', v'$ ) 1976 CIE chromaticity coordinates since the color space is more uniform relative to the eye's sensitivity to color. In this document we use photometric symbols:  $F, I, L, E, M$  for luminous flux, luminous intensity, luminance, illuminance, and luminous exitance, respectively. We use  $L$  for luminance and not the CIE tristimulus value  $Y$ . Please don't confuse our symbol for luminance  $L$  with any CIE measures for lightness (such as  $L^*$ ). Please note that the position coordinates ( $x, y, z$ ) are written in fonts with serifs, whereas the chromaticity coordinates ( $x, y, z$ ) and all other CIE variables  $L^*, X, Y, Z, u, v, u', v'$ , etc. are written sans-serif.



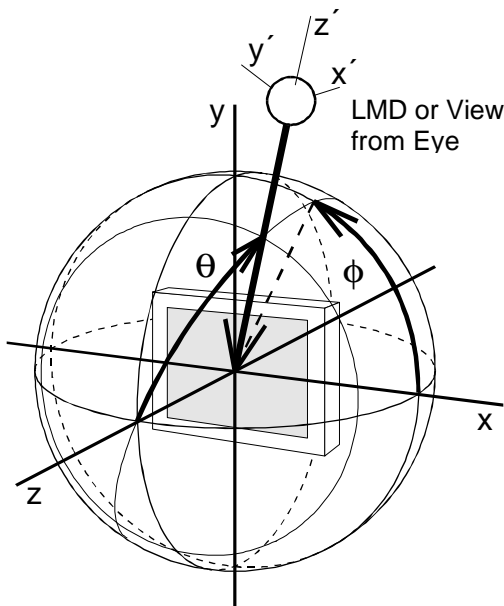
## 300-2 COORDINATES AND VIEWING ANGLES

**Cartesian Coordinates and Initial Alignment Conditions:** This document adopts right-handed  $x$ - $y$ - $z$  Cartesian coordinates with origin at the center of the screen. The  $z$ -axis is perpendicular (normal) to the screen, the  $x$ -axis is the screen horizontal, and the  $y$ -axis is the screen vertical. The  $x$  and  $y$ -axes lie in the plane of the display surface. We define the non-primed Cartesian system ( $x, y, z$ ) as being attached to the display and the primed Cartesian system ( $x', y', z'$ ) as being fixed in the laboratory. Figure 1 shows the laboratory coordinates aligned with the display coordinates. This is called the standard initial alignment. Standard initial alignment between the display coordinates and the laboratory coordinates are when the  $z'$ -axis is aligned with the  $z$ -axis of the display and the centers of both coordinate systems coincide at the center of the display surface. In the figures that follow, the laboratory system will be shown as separated from the display under test (DUT). This is done to reduce the complexity of the figures. It is to be understood that, in practice, the centers of the coordinate systems coincide. The center of the coordinate systems is at the intersection of the  $x$ - $y$ - $z$  axes



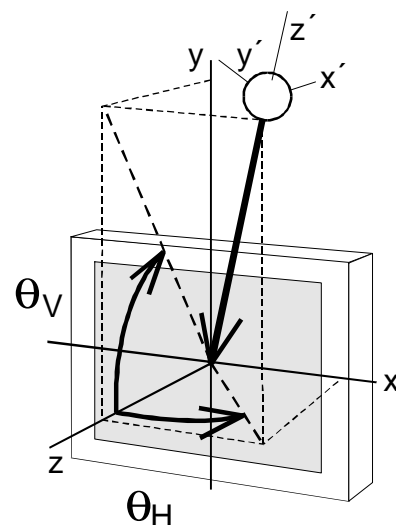
**Fig. 1.** Display coordinates (unprimed) and laboratory coordinates (primed).

**Spherical Coordinates:** Associated with this Cartesian system is the spherical coordinate system ( $r, q, f$ ), where  $r$  is the radius from the center of the display coordinate system,  $q$  is the inclination from the  $z$ -axis (display normal, the polar axis of the spherical coordinate system), and  $f$  is the counter-clockwise angle from the  $x$ -axis in the  $x$ - $y$ -plane (the display surface) as observed from the  $z$ -axis ( $f$  is a right handed rotation about the  $z$ -axis starting at the  $x$ -axis)—see Fig. 2. We represent the position of the observer or light-measuring device (LMD) with a spherical featureless eye. The laboratory coordinates are shown attached to the eye. Again, although the laboratory coordinates are drawn separated from the center, it is understood that the centers coincide at the display center.

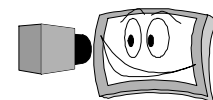


**Fig. 2.** Spherical coordinates.

## VIEWING-ANGLE COORDINATES



**Fig. 3.** Horizontal and vertical viewing angles used in this document.

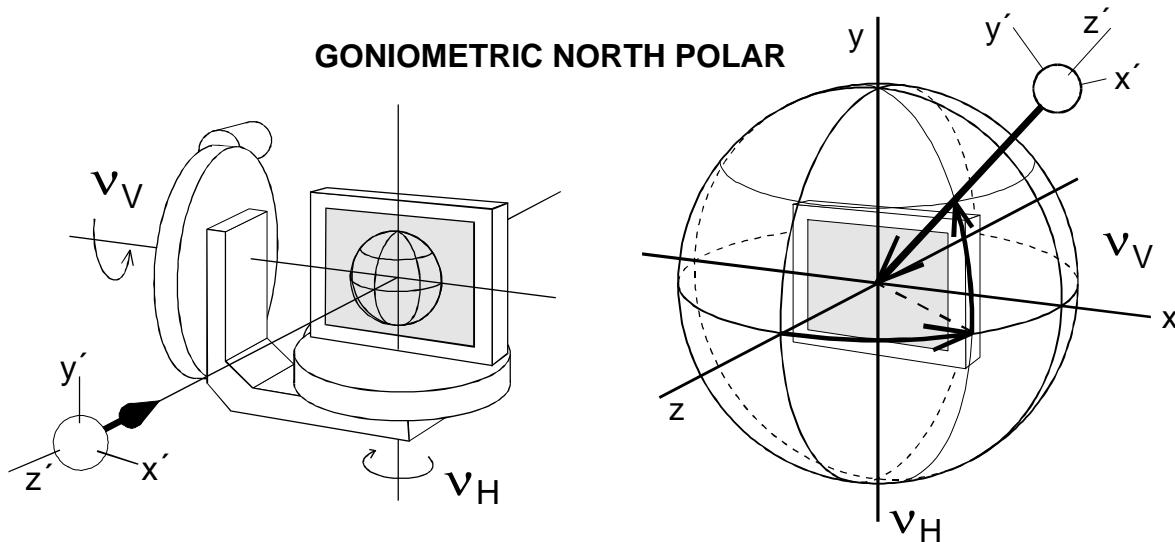


**Viewing Angles:** We define the horizontal  $q_H$  and vertical  $q_V$  viewing angles as the inclination angles of the viewing direction resolved into components in the horizontal  $z$ - $x$  plane and vertical  $z$ - $y$  plane respectively. Figure 3 shows that the viewing angles resolve the viewing direction into two orthogonal angles measured from the  $z$ -axis. Note also the rotation of the laboratory coordinates (attached to our eye) with the display coordinates.

This is the most natural coordinate system for viewing angles. It is the one we are thinking about when we look at displays from various angles. These are not same as the angles associated with goniometric systems in common use today. In the following, we present examples of goniometric coordinate systems commonly used and provide useful transformations for your reference.

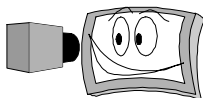
**Goniometric Configurations:** The goniometer is an apparatus that rotates the object under study relative to the measuring device where some point relative to the object (the center of the screen, for example) remains fixed in space (the axes of rotation go through the same point). This can be accomplished by rotating the LMD about the DUT, or conversely, by rotating the DUT while the LMD stays fixed. When the goniometer has two orthogonal rotational axes, one axis rotates with a rotation of the other axis. (A mirror gimbal mount is an example.) The axis that remains fixed is the independent axis. The axis that rotates about the independent axis is the dependent axis. There are two very common goniometer configurations that we describe below: north polar and east polar. The configurations shown tilt the display. Such systems assume that the direction of gravity and the direction of the earth's magnetic field have no effect on the display performance. These are by no means the only goniometric configurations that are possible. The equations shown in the following relate the viewing-angle coordinates (Fig. 3), the north-polar (Fig. 4), and the east-polar (Fig. 5) goniometric coordinate systems to the Cartesian (Fig. 1) and the spherical (Fig. 2) coordinate systems. These equations do not necessarily apply in all goniometric configurations.

**North Polar Goniometric Coordinates, Independent Axis Horizontal:** In this case, the independent axis of the goniometer is horizontal and the orthogonal (dependent) axis is rotated about the horizontal axis in a vertical plane. Figure 4 shows the goniometer aligned with the laboratory axes. Note the hemisphere on the surface of the display. The circular arcs on that sphere are traced out by the stationary  $z'$ -axis of the laboratory frame of reference as the display is rotated about the goniometer axes. Figure 5 shows an arbitrary viewing angle resolved into a horizontal rotation  $m_H$  about the  $y$ -axis (a right-handed rotation about the vertical  $y$ -axis) and a vertical rotation  $m_V$  about a horizontal axis in the  $x$ - $z$ -plane toward the  $y$ -axis. It is important to recognize that the rotational coordinates we are using here are defined relative to the coordinate axes attached to the screen. If we were to illustrate the display orientation indicated in Fig. 5 using the goniometer in Fig. 4, the display (its normal) would be pictured as being rotated to the left and then down. The angles  $m_H$  and  $m_V$  appear as opposite rotations in

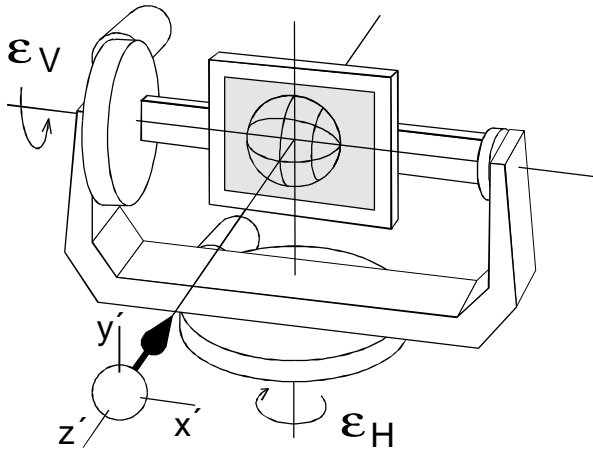


**Fig. 4.** North polar goniometer with independent axis horizontal.

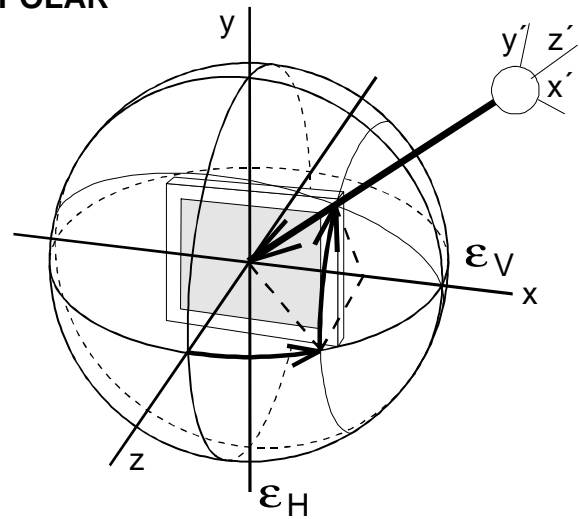
**Fig. 5.** North polar goniometric coordinates relative to the surface of the display.



**GONIOMETRIC EAST POLAR**



*Fig. 6. East polar goniometer with independent axis vertical.*



*Fig. 7. East polar goniometric coordinates relative to the surface of the display.*

Fig. 4 than the rotations pictured in Fig. 5. This is because we are looking at the rotations from the viewpoint of the display in Fig. 5 and the laboratory in Fig. 4.

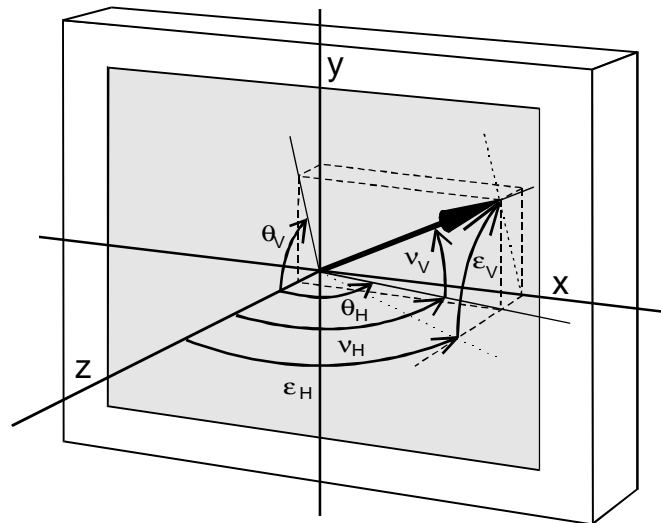
**East Polar Goniometric Coordinates, Independent Axis Vertical:** In this case, the independent axis of the goniometer is vertical and the orthogonal (dependent) axis is rotated about the vertical axis in a horizontal plane. Figure 6 shows the goniometer aligned with the laboratory axes. The circular arcs on the hemisphere on the display surface are traced out by the stationary  $z'$ -axis in the laboratory frame of reference as the display is rotated about the goniometer axes. Figure 7 shows an arbitrary viewing angle resolved into a horizontal rotation about the  $y$ -axis  $\epsilon_H$  (a right-handed rotation about the vertical  $y$ -axis) and a vertical rotation about the  $x$ -axis  $\epsilon_V$  (a left-handed rotation about the  $x$ -axis). Again, these coordinates are referenced to the screen coordinate system. The display orientation shown in Fig. 7 using the goniometer in Fig. 6 would show the display (its normal) rotated to the left and then down. The angles  $n_H$  and  $n_V$  appear as opposite rotations in Fig. 6 and 7, because we are looking at the rotations from the viewpoint of the display in Fig. 7 and the laboratory in Fig. 6.

In efforts to make it clear that the three coordinate systems are not the same, note Fig. 8 where we indicate the same viewing direction in the three horizontal-vertical coordinate systems described above: the horizontal-vertical viewing angle coordinates, the north-polar coordinates, and the east-polar coordinates. The horizontal viewing angle is the same as the north-polar horizontal rotation angle, and the vertical viewing angle is the same as the east-polar vertical rotation angle:

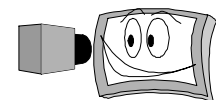
$$\begin{aligned} q_H &= n_H \\ q_V &= e_V. \end{aligned} \tag{1}$$

The equations expressing the relationships between these coordinate systems and with the spherical coordinate system can be derived by resolving into

**SUMMARY OF COORDINATES**



*Fig. 8. A viewing direction resolved into the three horizontal-vertical angular coordinate systems.*



Cartesian coordinates an arbitrary vector expressed in terms of these display coordinate systems, then requiring that the respective  $x$ ,  $y$ ,  $z$ -components be equal. Table 1 shows all the coordinate transformations for the five coordinate systems used. The more useful ones are highlighted with a thick-lined box. We recommend that spherical coordinates (Fig. 2) be used in the final reporting, or at least the viewing angle coordinates be used (Fig. 3) to avoid confusion.

### 300-3 VARIABLES USED IN THIS DOCUMENTS

In Table 2 we list most of the variables used in this document for your reference. This table also appears at the back of the document in A500.

### 300-4 MEASURES OF CONTRAST IN THIS DOCUMENT

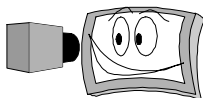
There are a number of measures of contrast contained in this document. We list them here for your reference. The star denotes that the measurement is included in the Suite of Basic Measurements. Contrast may not be the best metric to use to judge the black-white capabilities of a display, particularly when the contrasts are very high. Indeed, the ratio of  $L_w^*$  and  $L_b^*$  (see A201 and A209) would seem to be a better contrast metric. In any case, as long as all interested parties agree to any other metric used, then the measurement of white and black are detailed so any appropriate contrast metric may be employed. However, because of its historical and traditional use, we suggest that the full-screen white-black luminance ratio as the contrast metric for comparison purposes for direct-view displays until amore suitable metric becomes common in practice.

- 302-3\* CONTRAST RATIO OF FULL SCREEN
- 303-1 LINE CONTRAST RATIO
- 303-2 N×N GRILLE CONTRAST RATIO
- 303-5 INTRACHARACTER CONTRAST RATIO (M×N×Q GRILLE CONTRAST RATIO)
- 304-1 LUMINANCE AND CONTRAST RATIO OF CENTERED BOX
- 304-2 CENTERED BOX ON-OFF CONTRAST RATIO
- 304-3 TRANSVERSE CONTRAST RATIO OF BOX
- 304-9 CHECKERBOARD CONTRAST RATIO (N×M)
- 306-3 SAMPLED UNIFORMITY OF CONTRAST RATIO
- 308-2\* AMBIENT CONTRAST RATIO

**NOTE:** The full-screen contrast ratio is the contrast metric that is always assumed unless specified otherwise for direct-view display technologies (not necessarily projection systems or any display that places a lens between the pixel surface and the viewed image—head-mount, head-up, etc.). Any other contrast metric must be properly identified explicitly if it is not this full-screen contrast ratio. We strongly suggest the above  $C_R$  in any characterization of direct-view displays. If a non-perpendicular viewing angle is used it must be reported with the contrast value.

For example, if someone simply says that the contrast of their display is such-and-such, it must be referring to the full-screen  $C_R$  above. If a box contrast is used then it must be stated “the box contrast is...,” similarly for a  $4 \times 4$  checkerboard contrast, “the  $4 \times 4$  checkerboard contrast is...” In any case we strongly suggest that the above  $C_R$  always be reported.

If a viewing angle is employed such as  $4^\circ$  up vertically and  $C_R = 400$  whereas  $C_R = 250$  for the perpendicular we report as “The viewing contrast at  $4^\circ$  vertically up from perpendicular is 400:1,” or “400:1 at  $4^\circ$  up.” If the contrast at perpendicular is also included, state it clearly: “The contrast at the perpendicular is 250:1,” or “250:1 at  $0^\circ$ .”

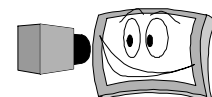


<b>Table 1a. Coordinate transformations.</b>			
$\text{asin } q \equiv \arcsin q \equiv \sin^{-1} q, \text{acos } q \equiv \arccos q \equiv \cos^{-1} q, \text{atan } q \equiv \arctan q \equiv \tan^{-1} q, 0 \leq q \leq \pi/2$			
$\downarrow = \rightarrow$	Horizontal and Vertical Viewing Angle $q_H, q_V = \text{Hor., Ver.}$	North Polar $n_H, n_V = \text{Hor., Ver.}$ (Independent Axis Vertical)	East Polar $e_H, e_V = \text{Hor., Ver.}$ (Independent Axis Horizontal)
Cartesian (Fig. 1) $x, y, z$	$x = r \sin q \cos f$ $y = r \sin q \sin f$ $z = r \cos q$ Use $q, f$ as below.	$x = r \sin n_H \cos n_V$ $y = r \sin n_V$ $z = r \cos n_H \cos n_V$	$x = r \sin e_H$ $y = r \cos e_H \sin e_V$ $z = r \cos e_H \cos e_V$
Spherical (Fig. 2) $q, f$	$q = \text{atan} \sqrt{\tan^2 q_H + \tan^2 q_V}$ $f = \text{atan}(\tan q_V / \tan q_H)$	$q = \text{acos}(\cos n_V \cos n_H)$ $f = \text{atan}(\tan n_V / \sin n_H)$	$q = \text{acos}(\cos e_V \cos e_H)$ $f = \text{atan}(\sin e_V / \tan e_H)$
H&V Viewing Angle (Fig. 3) $q_H, q_V$	1	$q_H = n_H$ $q_V = \text{atan}(\tan n_V / \cos n_H)$	$q_H = \text{atan}(\tan e_H / \cos e_V)$ $q_V = e_V$
North Polar (Fig. 4) $n_H, n_V$	$n_H = q_H$ $n_V = \text{atan}(\tan q_V \cos q_H)$	1	$n_H = \text{atan}(\tan e_H / \cos e_V)$ $n_V = \text{asin}(\cos e_H \sin e_V)$
East Polar (Fig. 5) $e_H, e_V$	$e_H = \text{atan}(\tan q_H \cos q_V)$ $e_V = q_V$	$e_H = \text{asin}(\cos n_V \sin n_H)$ $e_V = \text{atan}(\tan n_V / \cos n_H)$	1

<b>Table 1b. Coordinate transformations .</b>		
$\downarrow = \rightarrow$	Cartesian $x, y, z$ $r = \sqrt{x^2 + y^2 + z^2}$	Spherical $q, f$
Cartesian (Fig. 1) $x, y, z$	1	$x = r \sin q \cos f$ $y = r \sin q \sin f$ $z = r \cos q$
Spherical (Fig. 2) $q, f$	$q = \text{acos}(z/r)$ $f = \text{atan}(y/x)$	1
H&V Viewing Angle (Fig. 3) $q_H, q_V$	$q_H = \text{atan}(x/z)$ $q_V = \text{atan}(y/z)$	$q_H = \text{atan}(\tan q \cos f)$ $q_V = \text{atan}(\tan q \sin f)$
North Polar (Fig. 4) $n_H, n_V$	$n_H = \text{atan}(x/z)$ $n_V = \text{asin}(y/r)$	$n_H = \text{atan}(\tan q \cos f)$ $n_V = \text{asin}(\sin q \sin f)$
East Polar (Fig. 5) $e_H, e_V$	$e_H = \text{asin}(x/r)$ $e_V = \text{atan}(y/z)$	$e_H = \text{asin}(\sin q \cos f)$ $e_V = \text{atan}(\tan q \sin f)$

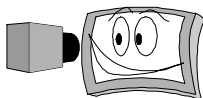


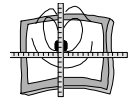
You think you're confused! It took us weeks to get this worked out!



**Table 2. Variables Used in This Document**

Abbreviations: <b>LMD</b> = light measuring device; <b>FOV</b> = field of view; <b>AFOV</b> = angular FOV; subpixel subscript $i$ = red, blu, grn, for example; subscript $j$ = bit or voltage level; <b>BRDF</b> = bidirectional reflectance distribution function; <b>CCD</b> = charge coupled device			
<i>Please Note: Throughout this document the screen or display surface refers to the visible pixel surface, only those pixels that contribute to the display of information. Any pixels behind a bezel are not included, neither is any border around the information-displaying surface included. The diagonal <math>D</math> is the measure of the diagonal of the viewable, information-displaying rectangular surface.</i>			
Symbol	Description	Symbol	Description
$a$	aspect ratio ( $a = H/V$ )	$N_T$	total number of pixels ( $N_T = N_H \times N_V$ )
$a$	small area, or small area of the screen	$N_V$	number of pixels in the vertical dimensions
$A$	area	$\pi$	3.141592653... = $4\arctan(1)$
$B$	BRDF	$P$	square pixel pitch (distance per pixel), power in watts (W), pressure
$C$	contrast ( $C_R$ = contrast ratio, $C_m$ = Michelson contrast, etc.)	$P_H$	horizontal pixel pitch
$D$	diagonal measure of viewable display , density	$P_V$	vertical pixel pitch
$d_a$	diameter of small area, target, or FOV	$Q$	Cluster defect dispersion quality (1/cluster density)
$n_H, n_V$ $e_H, e_V$	north-polar and east-polar goniometer angles	$R$	refresh rate, radius
$h$	luminous efficiency	$r, r_a$	radius, radius of round small area on the screen
$e$	frontal luminance efficiency	$s_i, s$	subpixel areas, small areas, distances
$E$	illuminance ( $lx = lm/m^2$ )	$S$	surface areas; signal level, or signal counts (as with using a CCD); also square pixel spatial frequency (pixels per unit distance, $S = 1/P$ )
$f$	fractional fill-factor threshold luminance	$S_H$	horizontal pixel spatial frequency
$f_a$	fractional (or percent) area of the screen for small area, target, or FOV	$S_V$	vertical pixel spatial frequency
$F$	luminous flux (lm)	$q, f$	spherical coordinates (see 300)
$H$	horizontal size of the screen.	$q_H, q_V$	horizontal, vertical viewing angles
$g$	gamma exponent in nonlinear fit (302-5)	$q_F$	AFOV of LMD
$I$	luminous intensity ( $cd = lm/sr$ )	$T_C$	correlated color temperature
$k$	detector conversion A/lm	$V, V_j$	vertical screen size, voltage, gray-scale levels
$K_i$	peak luminances of pixel subpixels	$W$	weight
$\lambda$	Wavelength	$W, w$	Solid angle
$L$	luminance ( $cd/m^2$ )	$x, y, z$	Cartesian right-handed coordinate system with $z$ perpendicular to the screen, $x$ horizontal, $y$ vertical
$L^*$	Lightness metric in CIELUV and CIELAB color spaces (see A201)	$u', v'$	1976 CIE chromaticity coordinates
$m$	mass	$u, v$	1960 CIE chromaticity coordinates (for CCT determinations)
$M$	luminous exitance ( $lx = lm/m^2$ )	$x, y, z$	1931 CIE chromaticity coordinates
$N_a$	number of pixels covered by a small area $a$	$X, Y, Z$	1931 CIE tristimulus values
$N_H$	number of pixels in horizontal dimension	$\bar{x}, \bar{y}, \bar{z}$	1931 CIE color matching functions

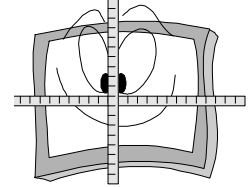




# 301 SETUP OF DISPLAY AND EQUIPMENT



The way the DUT (display under test) and its measurement equipment are set up is every bit as important as the measurements made on the DUT. The icons in the table below represent the setup conditions. These icons are fully explained in detail in section 301-2. There are three major divisions of this section:



**301-1 MEASUREMENT EQUIPMENT**

What measurement equipment is needed? The accuracy and precision required?

**301-2 MEASUREMENT AND DISPLAY CONDITIONS**

Here is a specification for setup conditions that are required to ensure replication of measurements from facility to facility. Setup icons in each measurement procedure economize space and can identify deviations in setup conditions quickly. A method for testing measurement uncertainty is specified.

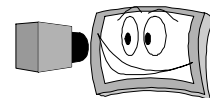
**301-3 DISPLAY SETUP AND INITIAL TESTING**

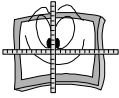
The way to initially adjust the DUT for the conditions under which it will be used is described. Various visual inspections are outlined which can be made during warm up.

OPTICAL SETUP

## SUMMARY OF SETUP CONDITIONS

	<p>Electrical conditions identified and documented.</p>		<p>Perpendicular viewing direction (or otherwise specified) with uncertainty goal of <math>\pm 0.3^\circ</math>. Exceptions must be reported.</p>
	<p>Environmental conditions:  <math>20^\circ\text{C} \pm 5^\circ\text{C}</math>                      86 kPa - 106 kPa                      (25 inHg - 31 inHg)                      25 % - 85 % RH (non condensing)</p>		<p>Sufficient number of pixels measured: 500 px is default                      Exceptions must be verified and reported</p>
	<p>Warm-up time: 20 min nominally (or sufficient). Exceptions must be verified and reported.</p>		<p>Measuring aperture of <math>2^\circ</math> (infinite focus) or less. Subtense of lens no greater than <math>2^\circ</math>. Exceptions must be verified and reported.</p>
	<p>Controls unchanged, once set, leave them alone.</p>		<p>Center screen measurement (or otherwise specified) with placement uncertainty of <math>\pm 3\%</math> of the screen diagonal.</p>
	<p>Darkroom conditions: 1 lx or less.</p>		<p>Adequate integration time for stable measurement.</p>





## 301-1 MEASUREMENT EQUIPMENT

### LIGHT MEASUREMENT DEVICE (LMD):

For a general discussion of the use of a suitable LMD, the kinds of measuring devices available, and more details concerning the field of view, etc., see the Metrology sections in the appendix: Light Measurement Devices (A103) also Spatial Invariance and Integration Times (A102). For a discussion of measurement uncertainties, see a discussion of the propagation of errors and uncertainty estimation in A108 Uncertainty Evaluations, and for the correct terminology see A221 Statements of Uncertainty. Any uncertainty values are expressed using an expanded uncertainty with a coverage factor of  $k = 2$  (a “two-standard-deviation” or “two-sigma” estimate)—see A221.

**For Luminances:** The luminance relative expanded uncertainty of measurement with coverage factor of two must be  $u_{LMD} = \pm 5\%$  of the luminance or less, and the luminance measurement repeatability must be less than either a maximum of  $s_{LMD} = \pm 0.5\%$  of the luminance or the uncertainty introduced by any digitization (whichever is larger) over a 5-min interval.

**For Color:** The expanded uncertainty of the measurement with coverage factor of two of chromaticity coordinates for tungsten-type CIE illuminant A above  $10 \text{ cd/m}^2$  must be  $\pm 0.002$  or less.

**Field of View for LMD and Subtense Angle of LMD:** The angle of the field of view (FOV), field angle, acceptance angle, or angular FOV (AFOV) of the measurement aperture must be  $2^\circ$  or less for infinity focus. Further, the angle subtended by the lens of the LMD from the center of the screen must also be  $2^\circ$  or less for image-producing systems (such as many luminance meters, colorimeters, and spectroradiometers that have a lens and viewfinder). There may be optical configurations that do not produce images on the photodetector of the LMD. This criterion is then equivalent to stating that all the rays coming from any pixel which contributes to the measurement made by the LMD must fall within a cone with apex angle of  $2^\circ$  or less. Further, all the rays coming from the centers of the measured pixels must be within  $2^\circ$  of the viewing direction. If the LMD used has an angular field of view larger than  $2^\circ$  then its suitability must be tested with the DUT; see Light Measurement Devices (A103) in the Metrology Appendix for diagnostics.

Some say FOV or aperture meaning the AFOV. The FOV can mean the horizontal (or maximum) size of an area viewed, or the width of the viewed area at a certain distance (binocular specifications). Aperture can refer to the measurement aperture within the instrumentation or the entrance pupil of the LMD. We will generally use AFOV.

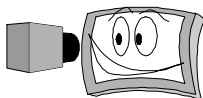
**Array Photodetectors:** Array photodetectors are used to provide a spatially resolved luminance measurement. In addition to the above requirements, such a system should provide (in either hardware or software) no more than  $\pm 2\%$  nonuniformity for all detection elements employed in a measurement of luminance. Further, the array must be filtered to make it photopic so that the CIE factor is  $f_1' \leq 5\%$  (see A103 for a discussion of  $f_1'$ ). If such LMDs are used to resolve fine detail at the pixel or subpixel level then the array pixel must measure no more than 1/10 the size of the smaller of the horizontal and vertical pixel or subpixel pitch on the DUT. There are many complications in using such devices, see the appendix for a more complete discussion and some of the CIE requirements: A103 (Light Measurement Devices) and A111 (Array Detector Measurements).

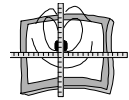
**Proximity Optical Fourier Transform Devices:** There are devices that are based on the use of the optical Fourier transform (OFT) of the image. OFT LMDs are often in close proximity with the display surface (a few millimeters away). Care must be exercised to avoid touching any delicate display surfaces. The OFT LMD provides a measurement of almost the entire  $2\pi$  sr hemisphere in front of the display. Since they employ array photodetectors, the requirements are presented above (Array Photodetectors). See A226 (Equipment Based on Fourier Optics) for a discussion of these devices and appropriate diagnostics.

**Temporal Measurements:** For some temporal measurements, a photopic response may not be required. However, sensitivity to infrared light (IR) can produce a dc offset that may or may not be important to an accurate measurement. The response time of the LMD is often required to be at least 1/10 the duration of the event measured such as with a pixel response-time measurement or the luminance fluctuations of a backlight. However, if the light generated is modulated at a high frequency as by a backlight, it may be necessary to require a response time of the LMD to be at most 1/10 the temporal period of the modulation.

### SIGNAL GENERATION:

In order to make this document apply to as many display technologies as possible, only some general remarks will be made concerning signal generation. The pixel responds to a driving stimulus. Depending upon the

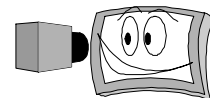
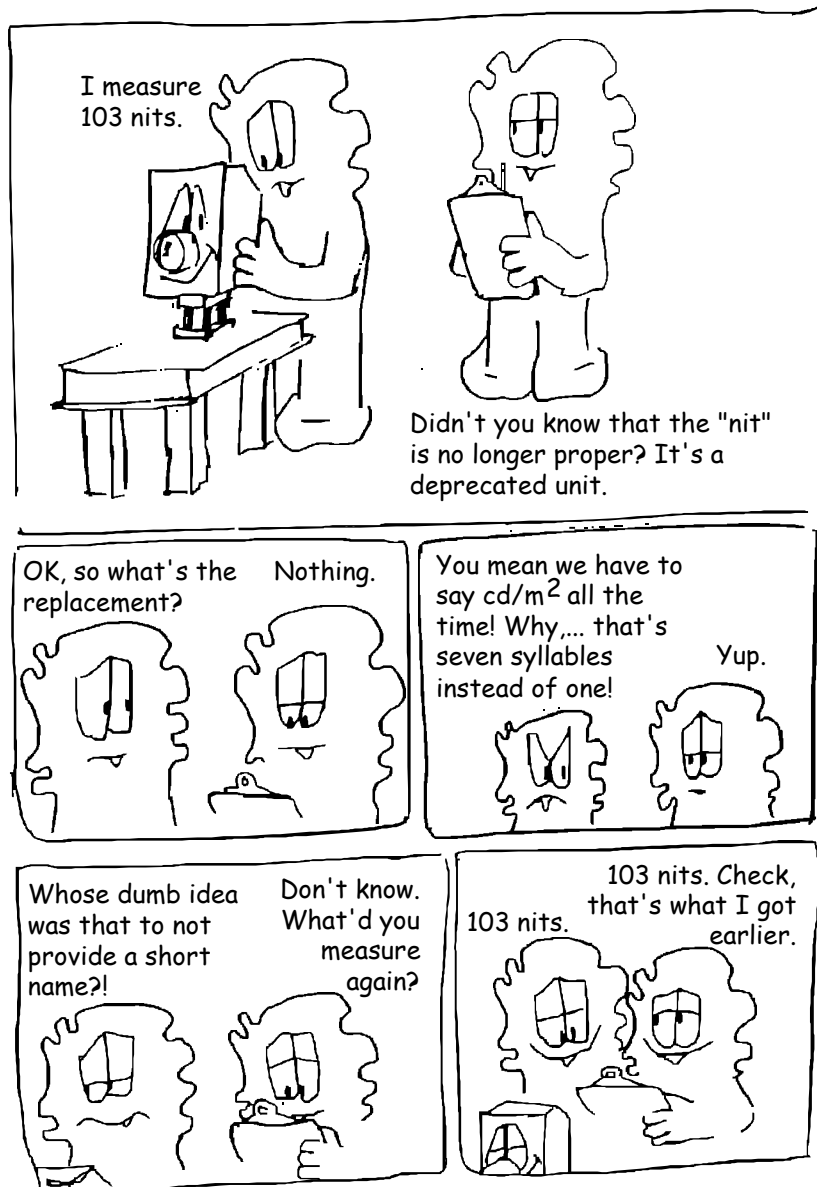


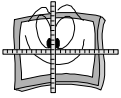


display technology, that driving stimulus can be an analog voltage such as that provided to an RGB CRT monitor, or it can be bit-level specified at a pixel location for a digital monitor associated with a computer digital interface. It is impossible to specify in a technology-independent way the point in the generation of the image on the DUT at which the user can access and specify the driving stimulus. Suffice it to say that, if a measurement requires introducing a signal generator to drive the DUT, that signal generator must not create artifacts that influence any of the measurements specified in this document within the precision of the measurements. To the extent that the user has control of the driving stimulus, the generation of that driving stimulus must be pre-calibrated so its effects are known. For example, consider an analog signal generator: The voltage levels must be accurate enough to establish a reliable relationship of voltage with the luminance levels of the pixels. Further, the transition times between voltage levels must be sufficiently fast so as not to induce measurable luminance artifacts between any two neighboring pixels. The adequacy of that driving stimulus is the responsibility of the user. In many cases, such as with a completed laptop computer, software will be utilized to display the various test patterns used in this document. When the signal is generated by a source external to the DUT, attention must be paid to the timing of the signal as well as aliasing problems because of inadequate temporal matches.

**OTHER EQUIPMENT:**

Depending upon what is being measured, there are a variety of other items that will be required or be found to be useful: oscilloscope (or equivalent signal digitizer or DSO [digital storage oscilloscope]), laboratory power supply, DVM (digital voltmeter), temperature measurement device (thermometer), very-low-impedance probe for the voltmeter or oscilloscope, signal generators, arbitrary waveform generators, and other general lab equipment. There are additional items which are found to be useful for making light measurements in general, see the Metrology Section under Auxiliary Laboratory Equipment (A113) for a listing of other useful laboratory items.





## 301-2 MEASUREMENT AND DISPLAY CONDITIONS



Here is a specification for setup conditions that is required to ensure reproducibility of measurements from facility to facility. The standard setup conditions are denoted by icons in each measurement procedure to economize space and to identify deviations in setup quickly. See 301-3a for display adjustment guidelines if not available from the manufacturer.

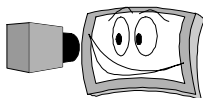
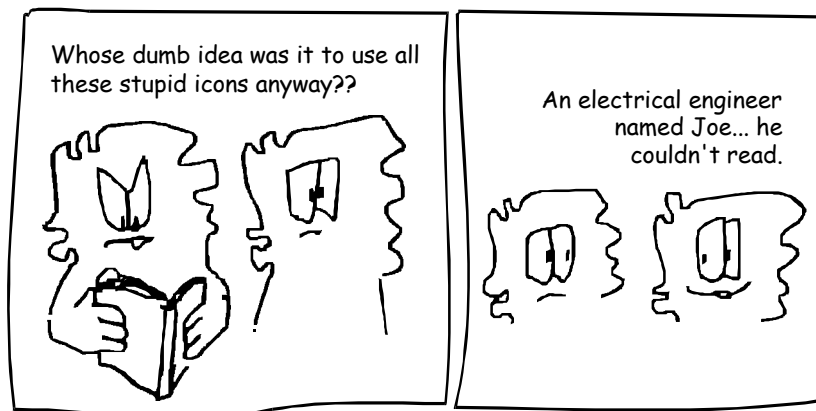
**A Note on Interface Conditions:** When possible it is recommended that the interface to the display be compliant with current VESA interface standards for monitors and flat panels. This generally assures proper signal compatibility between the system and the DUT. For digital displays complying with those standards, no adjustments to the display should have to be made other than brightness and, in some cases, contrast. For digital displays that have additional adjustments or displays with analog interfaces (in which case there may be many display adjustments), the user is advised to refer to the display manufacturer's setup and alignment procedures.

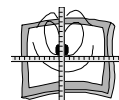
**Icons:** This section provides the details behind the setup icons appearing throughout the rest of the document and outlines some of the items that should be included on a reporting sheet. The thinking behind the icons was that an experienced user would become very familiar with the setup conditions and would need only a reminder of what is expected. In each measurement procedure, it is more important to point specifically to the unique or special setup conditions than to hide such specifications in familiar and repetitive verbiage. Reporting compliance with the setup conditions often amounts to placing a check in the checkbox next to the icon in the reporting sheet (if so provided, and where applicable); see SBM Report Form in the Reporting Section (200).

### 301-2a Description of Display and Other Identification

A number of items that identify the DUT and its environment should be included on any data sheet. In the following list, we don't generally include the humidity and air pressure unless there is reason to do so. See below for further specifications of setup conditions. See section 500 (Mechanical and Physical Characteristics) for any clarification needed on physical measurements of size, pixel pitch, diagonal measure, etc. If you are using one of the reporting sheets contained in this document (section 200), there are check boxes next to setup icons to indicate compliance with the setup conditions specified in this section. Where applicable, the information in Table 2 (header content of SBM report) should be specified.

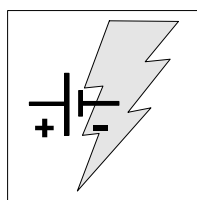
Some explanation for specifying the colors is in order. The "Bits per color" refers to the number of bits available for each primary color, e.g., in an RGB system there may be 5 bits available for red and blue but 6 bits available for green which can be written as "5,6,5/RGB," or "5R,6G,5B," whatever is clear; or if 8 bits are available for each color then we could write "8ea RGB," or simply "8 each." The "Total color bits" is the total number of bits available for color rendering (including grays). In the examples above, the 5,6,5/RGB system gives 16 bits for the total color bits, the 8-each system gives 24 bits for the total color bits. The gray levels are the number of distinct luminances of gray that the DUT is capable of producing, e.g., 8-bits of gray means there are  $2^8$  or 256 gray levels. The "Total number of colors" refers to the number of different colors that can be displayed at any one time. Thus, although a display may allocate 8 bits for each color RGB giving a palette of  $16.78 \times 10^6$  colors, if only 256 colors can be displayed at any time, then the total number of colors is 256.





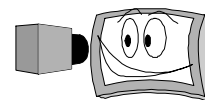
<b>DISPLAY INFORMATION:</b> Manufacturer of the DUT (display/device under test) Model number Serial number Revision level	<b>DESCRIPTION:</b> Diagonal Size Number of pixels horizontally Number of pixels vertically Technology of DUT Configuration
<b>PITCH:</b> Horizontal pixel pitch (metric units) Vertical pixel pitch (metric units) Horizontal subpixel (dot) pitch (metric units) Vertical subpixel (dot) pitch (metric units) Other specification (e.g., dots per inch—optional) Other specification (e.g., dots per inch—optional)	<b>STANDARD CONDITIONS:</b> Report compliance with standard setup conditions where applicable.
<b>COLORS:</b> Bits per color Total Color bits Gray levels Total number of colors	<b>DEVIATIONS MUST BE RECORDED</b> Measurement direction used if not perpendicular. (viewing point when needed) Location for the center measurement if not at center.
<b>DISPLAY SIZE AND MECHANICAL FACTS:</b> Active area: Horizontal x vertical measures Dimensions: Horizontal x vertical measures Depth Weight (mass) Design Viewing Direction	<b>SIGNAL AND POWER:</b> Signal source Power source
<b>LMD (light measuring device):</b> Make Model Serial number Distance Angular field of view (AFOV)	<b>OTHER INFORMATION:</b> Name of test person Date tested Warm-up time used Room temperature Run or data set number (if applicable)

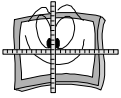
### 301-2b Electrical Conditions



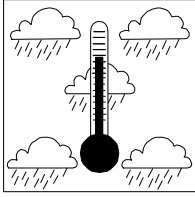
**Applied Power Setup and Power-up Conditions:** Apply power to the DUT (display under test). Three cases are presented. Case 3 should be used whenever possible, and Case 1 should be avoided if possible. Report compliance for which case applies. These are recommendations, any deviations should be reported. Should larger errors exist, they should also be reported.

- Case 1 - Battery:** A battery-operated display (with backlight where applicable, such as for many LCDs). Use an AC Adapter if possible. The time allocated for warm up may have to be shortened if a battery must be used for the entire test with no AC adapter. Assure that the battery is fully charged. This case is discouraged unless necessary.
- Case 2 - Embedded:** An embedded display (with backlight where applicable, such as for many LCDs) self-contained in a system, with system-provided power. Assure that the system is plugged into an AC source of proper voltage and frequency, as specified by manufacturer.
- Case 3 - External:** An external display (with backlight where applicable, such as for many LCDs), accessible outside a system and externally powered. Set the voltages of the external power supplies for the display's rated voltage(s)  $\pm 1\%$ . Note: Case 3 will provide the most accurate readings and is the preferred electrical setup method





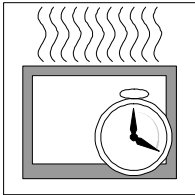
### 301-2c Environment



**Ambient Environment:** This assumes an environment similar to normal office conditions. If the DUT must be operated beyond the conditions described, use the conditions recommended by the manufacturer and agreed upon by all interested parties. Report compliance with conditions. Any deviation from these limits must be reported.

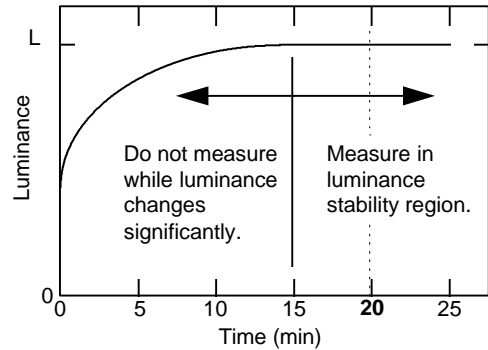
- Temperature:  $20^{\circ}\text{C} \pm 5^{\circ}\text{C}$
- Humidity: 25 % - 85 % RH, non-condensing
- Barometric Pressure: 86 kPa to 106 kPa (25 inHg to 31 inHg)  
(approximately sea level to 1400m)

### 301-2d Warm-Up Time



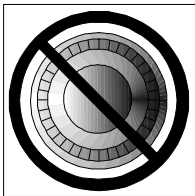
**Standard Warm-Up Time:** All displays must have adequate time after turn-on to allow a stable luminance level to be reached. After being turned on, the DUT and all associated electronics need to reach a level of thermal stability before the light output from the DUT is stable. This is the warm-up

time; it can be specified, or it can be measured. The normal warm-up time should be 20 minutes and can be used as the nominal warm-up period. *Note:* If you want to measure the warm-up time in case the nominal warm-up time is too long or too short for the DUT, follow the procedure given below in section 305-3 (Warm-Up Time Measurement). Report compliance with the requirement and report any exceptions from the 20 min warm-up time.



*Fig. 1. Example of a 20 min warm-up minimum for luminance stability.*

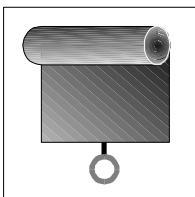
### 301-2e Controls Unchanged



**Displays with Controls:** Some displays have controls that permit altering one or more parameters such as brightness (luminance) or contrast. Once the controls have been set using either the manufacturer's procedures or the set-up procedures outlined below, they must not be changed during the course of all the measurements. That is, it is not permissible to change the controls in order to optimize the measurement. Should it be determined that a different control configuration is desirable after the measurements have started, then all the measurements must be retaken under the identical control configuration. The adjustment of

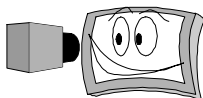
the DUT is discussed in section 301-3a Adjustment of Display Controls. Report compliance with requirement.

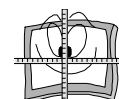
### 301-2f Darkroom Conditions



**Darkroom Conditions and Ambient Lighting:** Not only turning off all room lights and being careful about light from equipment in the room, but also reflections from surrounding objects back to the screen should be controlled to a negligible level. The illuminance  $E$  on the screen should be 1 lux or less ( $E \leq 1 \text{ lx}$ ). This is equivalent to stating that the luminance of a diffuse white surface at the position of the screen should have a luminance of less than  $0.32 \text{ cd/m}^2$ . However, there are cases where this specification is insufficient. In general, the goal is to avoid corruption of measured dark colors due to ambient light or reflections. Watch

out for reflections from clothing and equipment lights coming off of the screen and being measured as screen luminance. Whenever darkroom conditions are not needed this icon will be darkened and crossed out. Report compliance with conditions. Give consideration to the following:

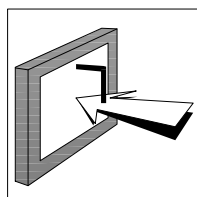




**Low Luminance Measurements:** For luminance measurements less than  $3 \text{ cd/m}^2$ , it is recommended that a diffuse white standard placed at the position of the screen have a reflected luminance of  $< 1/10$  of the lowest luminance reading to be measured. This is equivalent to requiring the illuminance  $E$  to be  $E < 0.1 \pi L$  for luminances  $L < 3 \text{ cd/m}^2$ .

**Reflections:** Best conditions assume a room that is completely dark and filled only with dark objects. Reflections from light-emitting devices or from bright or reflective surfaces could reflect off the surface of the DUT corrupting the measurement. This includes white clothing, lightly colored objects in the room, lights on instruments, computer displays, bright spots or light leaks in distant areas etc. Be aware of these problems and watch for them.

### 301-2g Standard Viewing Direction



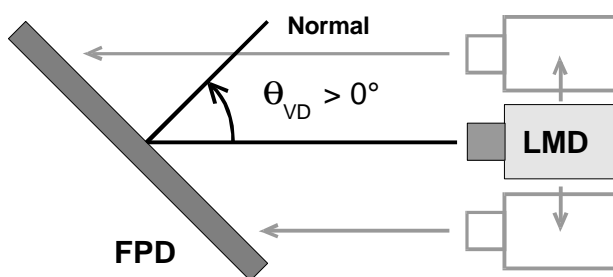
#### Perpendicular Viewing Direction:

The optical axis of the LMD should lie along a perpendicular to the screen; that is, the LMD should view the DUT along lines parallel to a perpendicular straight line directed out of the display surface. The

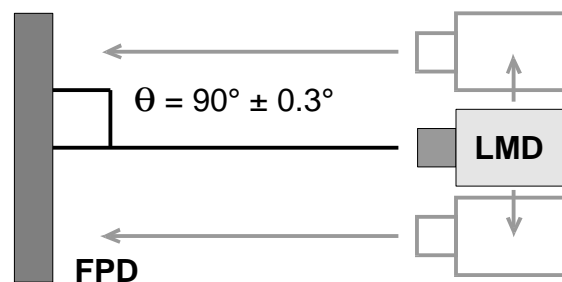
uncertainty in alignment with the normal is specified to be  $\pm 0.3^\circ$  as a goal. See Fig 3. For some FPDs a small misalignment with the normal can significantly contribute to errors in making highly angle-dependent measurements, such as might be the case for low-luminance measurements on some LCDs. Closely related to the viewing direction is the distance from which the measurement is made, and is discussed in the following section: Viewing Distance, Angle, and Aperture (301-2g). Report compliance with conditions or clearly indicate any other configuration.

The recommendation uncertainty of  $\pm 0.3^\circ$  is less tolerance than most would prefer, but is not overly restrictive or difficult to obtain. Keep in mind, that the moon and the sun subtend approximately  $0.5^\circ$ , and your thumbnail subtends approximately  $1^\circ$  with your arm fully extended; so  $\pm 0.3^\circ$  is, in fact, rather sloppy. Some methods for setup and verification of the normal direction are listed in the Metrology Section in the Appendix under Establishment of Normal (A117). **Extreme caution should be used, as some alignment methods are capable of damaging the surface of the DUT.**

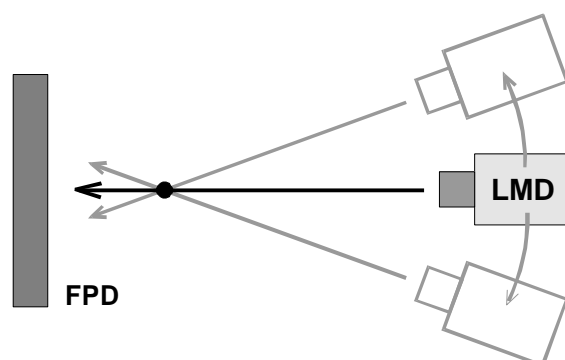
The recommendation uncertainty of  $\pm 0.3^\circ$  is less tolerance than most would prefer, but is not overly restrictive or difficult to obtain. Keep in mind, that the moon and the sun subtend approximately  $0.5^\circ$ , and your thumbnail subtends approximately  $1^\circ$  with your arm fully extended; so  $\pm 0.3^\circ$  is, in fact, rather sloppy. Some methods for setup and verification of the normal direction are listed in the Metrology Section in the Appendix under Establishment of Normal (A117). **Extreme caution should be used, as some alignment methods are capable of damaging the surface of the DUT.**



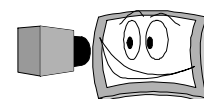
**Fig. 2.** Display with a design viewing direction that is not perpendicular to the screen.

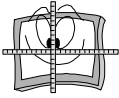


**Fig. 1.** Standard viewing direction is perpendicular and positioned at the center of the screen. Measuring at different points on the surface of the screen is pictured.



**Fig. 3.** Display with a design viewing point in space through which measurements should be made.



**EXCLUSIONS:**

For some displays (as with some LCD technologies), the luminance of black experiences a minimum in an off-perpendicular direction. The manufacturer may have anticipated that the display will always be used slightly tilted away from the perpendicular, and they designed its best performance to be found in an off-perpendicular design viewing direction. Some displays may have been designed for grossly non-perpendicular viewing directions, such as in an aircraft cockpit where a display may be positioned far to one side so that it would never be viewed from the perpendicular direction, see Fig. 2. *A non-perpendicular design viewing direction can be used only if it is clearly stated in all reporting and if all interested parties are made aware of the deviation from this specification.* This is not an invitation to move about the normal and find the darkest black. This non-perpendicular allowance refers to a design viewing direction. If the manufacturer designed it for  $10^\circ$  above normal, then measure it  $10^\circ$  above normal, and be sure to report it as a measurement made  $10^\circ$  above normal. If the black were darker at  $12^\circ$ , you would still use the measure at  $10^\circ$ . If the manufacturer has not specifically designated a non-normal viewing direction, then always use the normal or perpendicular direction for measurements.

A related issue to the design viewing direction is if there is a design viewing point. If a display is designed to be viewed from a point in space (as an example consider a privacy display for a banking machine) then it would not necessarily be appropriate to use the perpendicular direction for making all surface measurements on the screen, see Fig. 3. Conceivably, a display could even have a design viewing point that is not on the perpendicular of the display. *A design viewing point can be used only if it is clearly stated in all reporting and if all interested parties are made aware of the deviation from this specification.*

## 301-2h Viewing Distance, Angle, and Angular Field of View

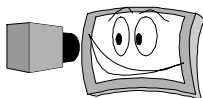
**SUMMARY:**

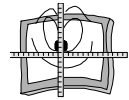
Measure 500 pixels or more but less than 10 % of both the horizontal and vertical dimensions of the screen (<1 % of screen area) using an LMD with a field of view angle of  $2^\circ$  or less for an infinity focus (or the equivalent). Further, the subtense angle of the lens as viewed from the screen must be  $2^\circ$  or less. For LMDs that are not to be operated in close proximity to the screen, a 500 mm distance is recommended. Devices or configurations that cannot comply with these restrictions must be verified. Report the following items on the reporting sheet: The LMD used (make, model, serial number), its distance from the screen, and its angular field of view. Also, report compliance with these suggestions on the reporting documentation.

**DISCUSSION:** (See A102-1 for more information.)

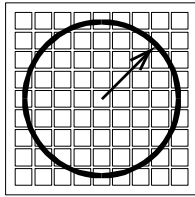
The overall goal is to provide a reproducible measurement (see A221, Statements of Uncertainty) that simulates what is seen by the eye. This means that we need to arrange for a measurement system that will provide a locally spatially-invariant measurement, a measurement that is independent of small perturbations in the position and small perturbations in the angle from the normal along which the measurement is made. There can be several kinds of LMDs employed for these measurements. There are non-proximity imaging LMDs (some refer to them as spot-meters), proximity non-imaging LMDs, and optical Fourier transform LMDs. Imaging LMDs use a lens to focus some part of the image of the DUT onto the light sensing elements of the LMD. *It is for such imaging LMDs that the above suggestion of 500 pixels, etc., is made.* Many imaging LMDs often are found with a viewfinder (or video viewfinder) and a spot or circle that identifies the region measured. Examples are imaging spectroradiometers, imaging luminance meters, hand-held imaging luminance meters and colorimeters, etc.

There are several types of non-imaging LMDs: (1) There are LMDs that employ collimated optics that do not create a focused image although a lens is used—see A219 (Collimated Optics). (2) Large solid angle LMDs that gather light from many directions onto one sensor are generally not useful for all FPD technologies—see A103 (Light Measurement Devices). (3) Optical Fourier transform LMDs are proximity detectors that can provide an angularly resolved measurement almost over the hemispherical region in front of the screen at one time—see A226 (Equipment Based on Fourier Optics). With any LMD, consideration must be given as to the parts of the screen that are contributing to the measurement so that the measurement is reproducible.



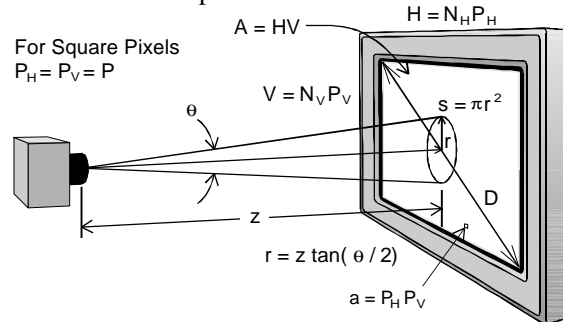


**NUMBER OF PIXELS MEASURED:**



At least 500 pixels should be measured to assure that small changes of position of the LMD or FPD will not result in important changes in the measurement. The 500-pixel arrangement also prevents localized pixel nonuniformities from affecting the measurement. That is, the luminance measurement should be locally spatially invariant. Further, the measurement area should be less than a box of size 0.1 H by 0.1 V (such a box retains the aspect ratio of the screen and has 1 % the area of the screen and 10 % the diagonal of the screen). Because pixels do not usually have a 100 % fill factor and are usually made up of colored subpixels having differing luminances, if too few pixels are being measured then

small changes (even a fraction of a millimeter) in the lateral position of the LMD or DUT can result in unacceptable errors in the measurement, and the measurement is no longer spatially invariant. In addition, if the pixel-to-pixel luminance nonuniformity is large, an inadvertently captured bright or dim pixel will affect the measurement when too few pixels are measured. Experience has shown that 500 pixels works well and can be used without further testing; 500 pixels is covered by a circle with a diameter of 26 (actually 25.2) square pixels. If it is necessary that fewer pixels be measured, the measurement configuration needs to be verified. LMDs or measurement situations that do not conform to the 500-pixel suggestion can be qualified for use by the appropriate diagnostic. See Section A102 (Spatial Invariance and Integration Times) for more details, worked examples, and more formulas to calculate how many pixels are covered. Here is one calculation of the number of pixels measured:



**FOR SQUARE PIXELS**

$$N = \frac{s}{a} = N_T \frac{s}{A} = \frac{\pi r^2}{HV} N_T = \frac{\pi r^2}{P^2}, \text{ or}$$

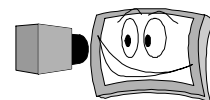
$$N = \pi \left[ \frac{z \tan(q/2)}{D} \right]^2 (N_H^2 + N_V^2), \text{ or}$$

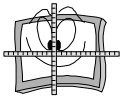
$$N \cong \frac{\pi}{4} d^2 \frac{(N_H^2 + N_V^2)}{D^2},$$

(where in the last equation it is assumed that  $z \gg r$ )

- A = area of the screen (viewable area, of course) comprising all pixels
- $N_{H,V}$  = number of pixels, horizontal, vertical
- $P_H, P_V$  = pixel pitch in the horizontal/vertical direction
- P = pixel pitch for square pixels
- H = horizontal size of screen =  $N_H P_H = N_H P$  (for square pixels)
- V = vertical size of screen =  $N_V P_V = N_V P$  (for square pixels)
- r = radius of round measurement area on screen
- s = area of screen being measured =  $\pi r^2$  (Goal:  $s < A/100$ )
- d =  $2r$  = diameter of round measurement area on screen (should be less than 10% of H and V)
- a = area allocated to one pixel =  $P_H P_V$  (=  $P^2$  for square pixels)
- $N_T$  = total number of pixels on the screen =  $N_H N_V$
- N = number of pixels being measured on the screen (Goal: 500 px)
- z = distance from the screen to the LMD
- D = diagonal =  $\sqrt{H^2 + V^2} = P \sqrt{N_H^2 + N_V^2}$
- Note that D is the exact diagonal of the viewable display surface.
- q = LMD angular field of view ( $^\circ$  or rad:  $^\circ = \text{rad} \cdot 360^\circ/2\pi$ )
- (NOTE: for small angles  $< 10^\circ$ ,  $\sin q \cong \tan q \cong q$  within 1%, where q  $\cong d/z$  must be in radians)

Table 1 provides examples of compliance and non-compliance with this pixel-quantity convention. For spot-meters, when the viewing angle q is not perpendicular to the screen, then if the radius from the screen center to the LMD doesn't change (not required in this document), the number of pixels measured increases as  $1/\cos q$  until the





spot covers the width of the screen for large angles. The area measured can then be more than 1 % of the screen. The 1 % measurement area limit is required for the standard perpendicular direction only.

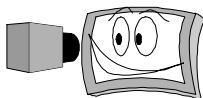
**Table 1. Number of Pixels Measured and Percent of Screen Diagonal Measured for Several Configurations.**

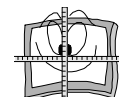
Dec.=decimal, No.=number of,  $z$  = distance between DUT and LMD,  $q$  = AFOV,  $a$  = aspect ratio,  $D$  = diagonal

The shaded area denotes failure to comply with 500-pixel and  $\leq 10$  %-of-diagonal convention.

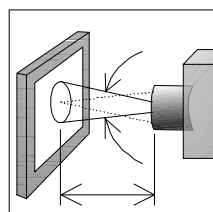
Display Pixels		Diagonal		$z$ (mm)	$q$ (°)	Aspect Ratio $a$		Size of Screen				Measurement Region		No. pixels $N$	
$N_H$	$N_V$	(in)	(mm)			Dec.	Ratio	$H$ (in)	$V$ (in)	$H$ (mm)	$V$ (mm)	$d = 2r$ (mm)	in % of $D$		% Area
640	480	10.4	264	500	2	1.333	4:3	8.32	6.24	211	158	17.46	<b>6.6%</b>	0.71%	<b>2195</b>
640	480	21.0	533	500	2	1.333	4:3	16.80	12.60	427	320	17.46	<b>3.3%</b>	0.18%	<b>538</b>
640	480	21.0	533	500	1	1.333	4:3	16.80	12.60	427	320	8.73	<b>1.6%</b>	0.04%	<b>135</b>
640	480	21.0	533	500	2	1.333	4:3	16.80	12.60	427	320	17.46	<b>3.3%</b>	0.18%	<b>538</b>
640	480	5.2	132	500	2	1.333	4:3	4.16	3.12	106	79	17.46	<b>13.2%</b>	2.86%	<b>8779</b>
640	480	5.2	132	500	1	1.333	4:3	4.16	3.12	106	79	8.73	<b>6.6%</b>	0.71%	<b>2194</b>
640	480	32.0	813	500	2	1.333	4:3	25.60	19.20	650	488	17.46	<b>2.1%</b>	0.08%	<b>232</b>
800	600	11.3	287	500	2	1.333	4:3	9.04	6.78	230	172	17.46	<b>6.1%</b>	0.61%	<b>2905</b>
800	600	15.0	381	500	2	1.333	4:3	12.00	9.00	305	229	17.46	<b>4.6%</b>	0.34%	<b>1648</b>
800	600	22.6	574	500	2	1.333	4:3	18.08	13.56	459	344	17.46	<b>3.0%</b>	0.15%	<b>726</b>
1024	768	12.1	307	500	2	1.333	4:3	9.68	7.26	246	184	17.46	<b>5.7%</b>	0.53%	<b>4151</b>
1024	768	15.0	381	500	2	1.333	4:3	12.00	9.00	305	229	17.46	<b>4.6%</b>	0.34%	<b>2701</b>
1024	768	6.4	163	500	2	1.333	4:3	5.12	3.84	130	98	17.46	<b>10.7%</b>	1.89%	<b>14836</b>
1024	768	6.4	163	500	1	1.333	4:3	5.12	3.84	130	98	8.73	<b>5.4%</b>	0.47%	<b>3709</b>
1024	768	21.0	533	500	2	1.333	4:3	16.80	12.60	427	320	17.46	<b>3.3%</b>	0.18%	<b>1378</b>
1280	1024	13.0	330	500	2	1.250	5:4	10.15	8.12	258	206	17.46	<b>5.3%</b>	0.45%	<b>5897</b>
1280	1024	25.0	635	500	2	1.250	5:4	19.52	15.62	496	397	17.46	<b>2.7%</b>	0.12%	<b>1595</b>
1280	1024	17.0	432	500	2	1.250	5:4	13.27	10.62	337	270	17.46	<b>4.0%</b>	0.26%	<b>3449</b>
1280	1024	42.0	1067	500	2	1.250	5:4	32.80	26.24	833	666	17.46	<b>1.6%</b>	0.04%	<b>565</b>
1280	1024	23.0	584	500	1	1.250	5:4	17.96	14.37	456	365	8.73	<b>1.5%</b>	0.04%	<b>471</b>
1280	1024	23.0	584	500	2	1.250	5:4	17.96	14.37	456	365	17.46	<b>3.0%</b>	0.14%	<b>1884</b>
1280	1024	60.0	1524	500	2	1.250	5:4	46.85	37.48	1190	952	17.46	<b>1.1%</b>	0.02%	<b>277</b>
1920	1080	17.0	432	500	2	1.778	16:9	14.82	8.33	376	212	17.46	<b>4.0%</b>	0.30%	<b>6228</b>
1920	1080	42.0	1067	500	2	1.778	16:9	36.61	20.59	930	523	17.46	<b>1.6%</b>	0.05%	<b>1020</b>
1920	1080	12.0	305	500	2	1.778	16:9	10.46	5.88	266	149	17.46	<b>5.7%</b>	0.60%	<b>12500</b>
3072	2240	13.5	343	500	2	1.371	11:8	10.91	7.95	277	202	17.46	<b>5.1%</b>	0.43%	<b>29418</b>

SETUP OPTICAL





### IMAGING LMDs FIELD OF VIEW AND SUBTENSE ANGLE:



Many LMDs use a lens to focus an image of the DUT some part of which is measured or sampled by the light measurement elements. The angular field of view (AFOV) of the LMD should be  $2^\circ$  or less and the lens of the LMD must subtend no more than  $2^\circ$  from the center of the measurement area on the screen.

For imaging spot meters the  $2^\circ$  criterion is based on a focus at infinity.

If light measured from a DUT exhibits a viewing-angle dependence, then the finite solid angle subtended by the LMD measurement aperture may affect the measurement since it receives light from different parts of the screen at slightly different angles. If an LMD is used with an AFOV greater than  $2^\circ$ , its adequacy must be checked with each display measured to be sure that the variation of the measured quantity is less than twice the maximum repeatability requirement for the LMD (in this document,  $s_{LMD} = 0.50\%$ , so that  $1\% = 2 \times s_{LMD}$ ) over the AFOV employed, see A103 for diagnostics. Some measurements require a smaller subtense angle than  $2^\circ$ , such as BRDF measurements of reflection and other reflection measurements. Such requirements will be clearly stated. The angle subtended by a lens of diameter  $D_L$  at a distance  $z$  from the screen is

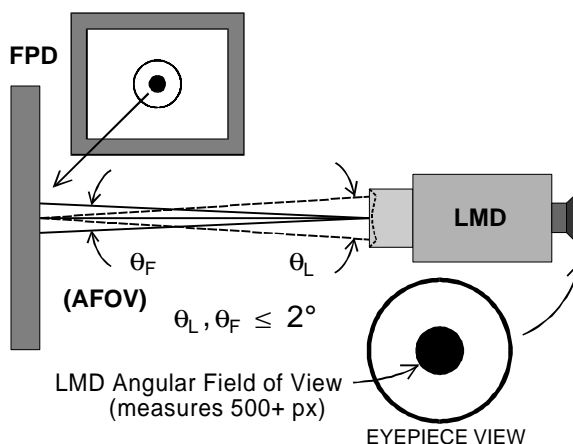
to be sure that the variation of the measured quantity is less than twice the maximum repeatability requirement for the LMD (in this document,  $s_{LMD} = 0.50\%$ , so that  $1\% = 2 \times s_{LMD}$ ) over the AFOV employed, see A103 for diagnostics. Some measurements require a smaller subtense angle than  $2^\circ$ , such as BRDF measurements of reflection and other reflection measurements. Such requirements will be clearly stated. The angle subtended by a lens of diameter  $D_L$  at a distance  $z$  from the screen is

$$q_L = 360^\circ \frac{D_L}{2\pi z}, \quad \begin{cases} q_L = \text{subtense angle in degrees} \\ D_L = \text{diameter of lens} \\ z = \text{distance from screen} \end{cases}$$

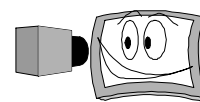
See section (A103 Light Measurement Devices) for diagnostics to test any LMD for meeting these specifications.

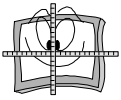
### NON-IMAGING LMDs:

The limitations required here are essentially the same as for an imaging LMD but expressed in a more general sense to accommodate non-imaging systems: Each pixel that contributes to the measurement should only contribute a narrow cone of light that is measured by the LMD. The apex angle of that cone should be  $2^\circ$  or less. Furthermore, for each pixel that contributes to the measurement, the center axis of this cone of light should be within  $\pm 1^\circ$  of the optical axis of the LMD. See section A103 (Light Measurement Devices) for diagnostics to test any LMD for meeting these specifications.



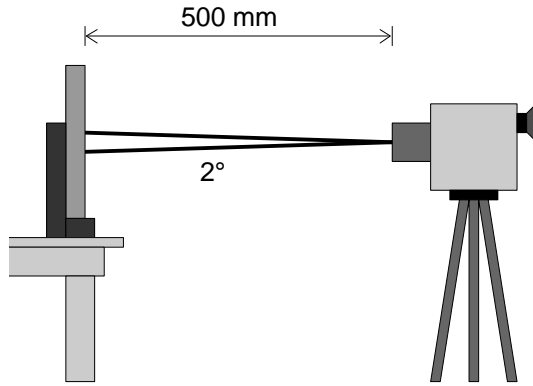
**Fig. 1.** Angular field-of-view  $q_F$  and angle subtended by lens  $q_L$  both limited to less than or equal to  $2^\circ$ .



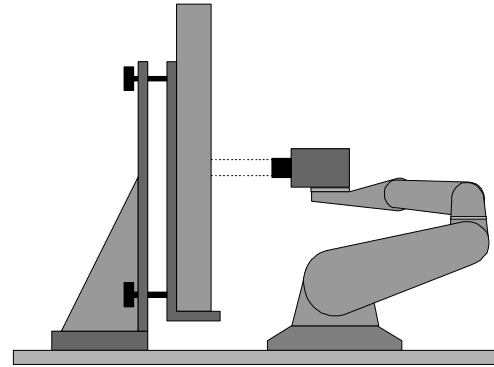


**CONFIGURATION EXAMPLES:**

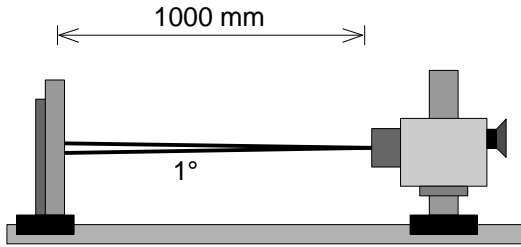
In Figs. 2-4 we show three typical configurations, and in Table 1 we show some examples using common screen pixel configurations (the last two entries do not conform to this specification;  $N_H$  and  $N_V$  are the number of pixels in the horizontal and vertical direction,  $H$  and  $V$  are the horizontal and vertical sizes, respectively). See section A102 (Spatial Invariance and Integration Times) for methods to calculate how many pixels are covered.



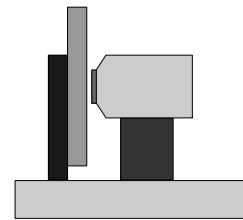
**Fig. 2.** Example of a typical  $2^\circ$  field-angle spot-meter LMD at 500 mm from the display in a laboratory bench and tripod configuration where the LMD and display are fixed in space.



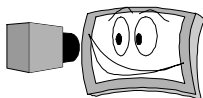
**Fig. 3.** Example of an automated or robotic LMD laboratory configuration with display fixed.

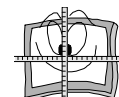


**Fig. 4.** Example of a typical  $1^\circ$  aperture LMD at 1 m from the display in an optical rail configuration where the LMD and display are securely fixed in place.

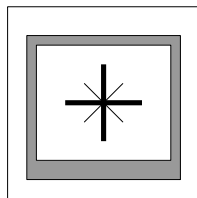


**Fig. 5.** Example of an optical-fourier-transform LMD.





## 301-2i Screen Measurement Points



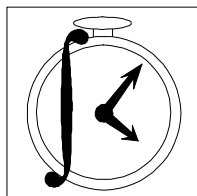
### CENTER SCREEN MEASUREMENTS:

Many of the measurements in this document are made at the center of the screen. We specify that the center of the screen be determined within  $\pm 3\%$  of the screen diagonal size. That is, the center of the luminance meter angular-field-of-view (AFOV) must be positioned at the center-screen point to within  $\pm 3\%$  of the screen diagonal. Whenever center-screen measurements are not called for this icon will be crossed out and darkened. Some displays have a seam at the center such as dual-scanned displays or tiled displays where it would be unreasonable to measure directly at the center across the seam. In such cases, measure as close to the center as possible being careful to avoid the seam by at least 10% of the measurement circle AFOV, and note the measurement position in the report. Report compliance or any exceptions on the data or report sheet.

**Positions Other Than Screen Center:** Various discrete points on the screen surface other than the center are employed in several measurements (such as sampled uniformity measurements). All such points must be located to within  $\pm 3\%$  of the screen diagonal. That is, the center of the luminance meter measurement AFOV must be positioned at these points to within  $\pm 3\%$  of the screen diagonal.

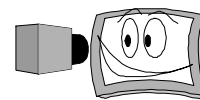
**Verification:** By looking through the viewfinder or a video representation of the view it is usually a simple matter to locate these measurement points. Two methods for setup and verification are as follows: (1) By alignment of the measurement device to a displayed image which is generated to specifically locate the measurement point on the screen (see the file series FPDMSU). (2) Mechanical determination of the center of the screen and other measurement points such as by use of an external template; diagonal cross-hairs and measured horizontal and vertical cross-hairs using strings, rubber bands, long strands of hair, thread, etc.

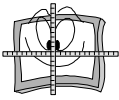
## 301-2j Adequate Integration Time



### TEMPORAL MODULATION OF LUMINANCE:

With the LMD and DUT rigidly fixed, the variation in luminance readings should be within twice the maximum repeatability requirement for the LMD (in this document,  $s_{LMD} = 0.5\%$ ) over a short period of time. That is, the luminance measurement should be repeatable. If this is not the case then either the luminance meter is unstable, the display is unstable, or the display is putting out a temporally modulated luminance causing the measured luminance to be sensitive to the placement in time and duration of the time interval over which each individual measurement is made. See the next section for testing the luminance measurement stability: Luminance Measurement Repeatability (301-2k). See the section in the Metrology Appendix for a more complete discussion of the problem, more detailed diagnostics, and ways to correct the problem: Spatial Invariance and Integration Times (A102).



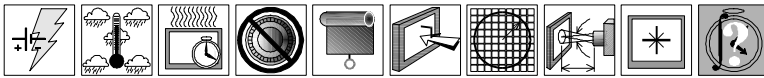


### 301-2k Luminance Measurement Repeatability

**DESCRIPTION:** Most measurements made using this document depend upon the repeatability of the measurement of luminance. This procedure is used to assess the repeatability of the luminance measurement, and provides an estimate of the mean and standard deviation of the luminance measurement by making 10 measurements of the luminance of full-screen white. The LMD, the DUT, or both in concert can cause non-repeatability. **Units:** cd/m<sup>2</sup> for mean and standard deviation. **Symbols:**  $m_L$  and  $s_L$  respectively.

**SETUP:** Display a white full-screen test pattern and arrange the luminance meter to measure the luminance at screen center from the perpendicular direction. Be sure that the luminance meter and the DUT are securely in place and will not change in their positions during the measurements. (This measurement is a method of determining the adequacy of the integration time of the LMD, hence the question mark over the last icon below.) See section 301 for any standard setup details.

**SPECIFIC:** Full screen white



**PROCEDURE:** Measure the center-screen luminance of full-screen white 10 times as quickly as is reasonably possible. Graph the luminance as function of the measurement order number, one through ten (which provides an approximation to the luminance as a function of time).

**ANALYSIS:** Calculate the mean and standard deviation for the luminance measurements, and examine the graph of the results to see if there is any drift due to inadequate warm-up of either the DUT or the LMD. The mean  $m_L$  of  $n = 10$  measurements of the luminance  $L_i$  is

$$m_L = \frac{1}{n} \sum_{i=1}^n L_i,$$

and the standard deviation is

$$s_L = \sqrt{\frac{1}{n-1} \sum_{i=1}^n (L_i - m_L)^2}.$$

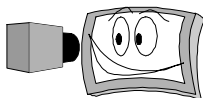
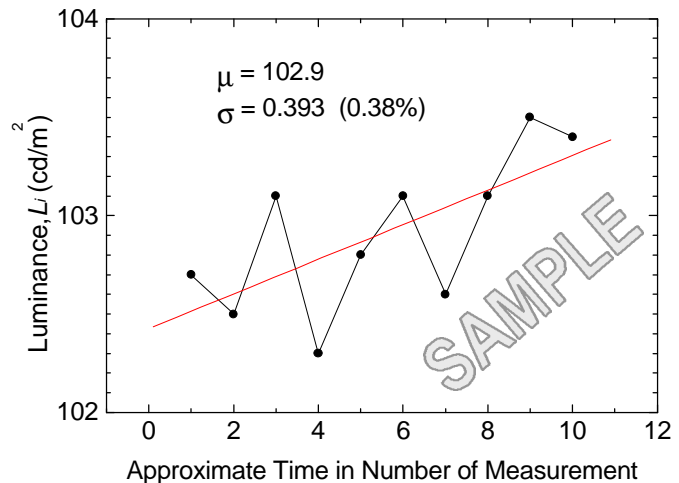
If there is an overall drift in the values which results in the primary contribution to the standard deviation, then it may be wise to wait until warm up is achieved and attempt a re-measurement.

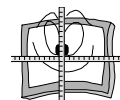
**REPORTING:** None, unless called for by the interested parties. Some may wish to report the mean and standard deviation of these ten measurements in the comments if the reporting document permits.

**COMMENTS:** In the graph of the sample data we see an upward drift in the luminance (the line is a linear fit to the data), but the standard deviation is within the limits of twice the requisite imprecision of the LMD or  $\pm 0.5\%$  indicating that the luminance measurement is adequate for the purposes of this standard. This measurement can be used in conjunction with 301-2j (Adequate Integration Time).

*Note:* Although we have specified a luminance measurement in this example, any measurement result can be dealt with in a similar fashion, e.g., chromaticity coordinates.

Luminance $\mu$ and $\sigma$	
$L_1$	102.7
$L_2$	102.5
$L_3$	103.1
$L_4$	102.3
$L_5$	102.8
$L_6$	103.1
$L_7$	102.6
$L_8$	103.1
$L_9$	103.5
$L_{10}$	103.4
$m_L$	102.3
$s_L$	0.393





## 301-3 DISPLAY SETUP AND INITIAL TESTING



During the 20-minute warm up period (or whatever period is required for warm-up) certain subjective observations can be made. Also, any controls on the DUT can be set to provide the best images or patterns commensurate with the use of the display and its task setting (consistent with the manufacturer's specifications, if they exist or apply). We have provided one section on Adjustment of Display Controls (301-3a), and a number of sections on subjective evaluations. The subjective evaluations are suggested, not mandatory.

### Some Possible Subjective Evaluations:

- 301-3a Adjustment of Display Controls
- 301-3b Saturated Color Performance Assessment
- 301-3c Cosmetic Defects Assessment
- 301-3d Mura Assessment
- 301-3e Pixel Defects Assessment
- 301-3f Flicker Visibility Assessment
- 301-3g Video Artifacts Assessment
- 301-3h Single-Pixel Checkerboard Testing

The sections on subjective evaluations allows for a visual check to determine the presence of certain display conditions or anomalies and give guidelines to help determine the level of seriousness of problems. With the exception of the Saturated Color Performance Check (301-3b), presence of any of these conditions is usually undesirable and degrades the quality of displayed video or the appearance of the display. Some displays will have some of these characteristics, and some will not.

All of the tests are made by human visual observation with no measurement equipment, unless specifically stated within a test. There may be visual enhancement aids, such as magnifiers or optical filters, which can assist the evaluations. It is important to note that visual testing infers looking for visual problems which may or may not be present rather than measuring performance as is done for the regular testing sections of this standard. Saturated Color Performance Check (301-3b) is the exception. For color displays, the colors are expected to be present. Absence of the colors or video artifacts on the way the colors are displayed would suggest a serious problem. It is recognized that subjective evaluations depend upon the observer. For example, some people exhibit a much greater sensitivity to flicker than others. These evaluations are intended to flag the most obvious problems.

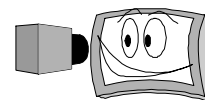
Should any of the tests of this section not be completed during the warm-up interval, they may be tested at any time thereafter. It is assumed all tests in this section are immune to warm up time, and that the order of the tests is during warm up is not a factor. Should any of these tests be deemed to dependent upon warm up time, they should be conducted after proper warm up time has been achieved.

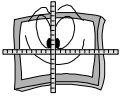
### 301-3a Adjustment of Display Controls

**NOTE:** If you intend to make a measurement that requires the display to be turned off or the controls changed (such as Luminance Adjustment Range, 302-8, and reflection measurements, 308), it is wise to make these measurements before establishing the settings to be used for all other measurements. Alternatively, perform such measurements after all other measurements have been made.

**Control Adjustment:** Should the DUT be provided with any adjustment controls such as brightness or contrast, etc., the display controls should be set according to manufacturer's specifications and not be changed during the course of the measurements (see 301-2e, Controls Unchanged, in the above). It is important to adjust the DUT commensurate with its intended task and not optimize the DUT for each measurement separately. In the event that no manufacturer specifications exist or are not adequate for the intended purpose of the DUT, we recommend the use of targets and images available from VESA.

**Set-Up Images:** The appropriate set-up patterns and images, Setup Images, can be obtained from the VESA world-wide-web page at address [www.vesa.org](http://www.vesa.org), download the appropriate file with name FPDMSU.??? where ??? is "PPT" for Microsoft's PowerPoint® use on the PC (personal computer) and "PDF" for Adobe's Portable Document Format® where Adobe's reader is also available from the web site for several platforms. There are several bit-mapped patterns that must be kept in a separate file FPDMSUBM.???. This file contains SMPTE-like patterns with modifications (see SMPTE RP 133-1991 Specifications for Medical Diagnostic Image Test



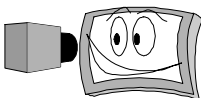


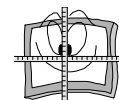
Pattern for Television Monitors and Hard-Copy Recording Cameras). as well as some other patterns that may be of use in setting up a display—see Section A112 in the appendix for details.

The Set-Up Images have text, photographic images, test targets, and alignment targets for assuring the DUT is adjusted for its intended use. There are 32 gray levels provided on several targets and included also with the images. The controls should be adjusted so that the gray levels near black and near white are visible. Beyond that, probably a face will be found to provide the most restrictive adjustment of the controls and is therefore suggested where appropriate, should any fine-tuning be required. The general characteristics of these files and examples are described in the Metrology Section under Images and Patterns for Procedures (A112). Further discussion of their use will be found in that section. Most of these patterns are simple, so you may want to create your own.

In some cases, it is possible to adjust some displays so that the full black screen is absolutely black to the eye (in a darkroom) and to your instrumentation. If with such a display under normal operating conditions the *full* gray scale is visible, then the display effectively has infinite contrast. However, this is very unlikely. Usually, if there is any nontrivial luminance in the bright areas of the display, the display will require a black luminance that is finite in order for the eye to be able to see the first gray (or color) level above black. Thus, it is not enough to adjust so that the first gray level is visible above black, but that the first gray level above black must be observable during normal use of the display. The establishment of black along with whatever gray scale (or color scale) is used to set the controls of the display will be task and technology dependent. We cannot cover all concerns here. For example, there are tasks that require using the display in a dark room where it is considered acceptable to make adjustments in brightness or contrast for the purposes of identification of parts of an image. Viewers may make a different adjustment to suite their requirements. For such unusual display tasks, the settings should not be changed during the measurements for each separate ambient condition (dark room, bright room, red room, etc.). However, if the settings are changed, all the measurements must be identified by their ambient condition and control settings. In general, if the display is said to have  $N$  gray levels that are required for proper use of the display (for example, 256) then the gray scale level next to black should be visible for use under typical operating conditions. If full gray-scale reproduction is not required or desired, then that fact should be reported to assure a reproducible measurement. Whatever is decided must be suitable to all interested parties.

In cases where the above 32 gray levels do not adequately exercise the display's capabilities, more levels may be needed. Here is a procedure that may be of use: Suppose we have a display that is capable of displaying 1024 levels of gray. Fill the screen with filled rectangles (without boundary lines) ranging from white to black in any convenient even-bit step size, but as black is approached, use only a step size of one bit. The display must be adjusted so that the first level above black is visible with these other luminance levels on the screen. Thus, we might arrange for a matrix of rectangles 16 across and 8 down to fill the screen; the step size would be approximately 8 bits until you approached the black rectangle, then steps might go like 1023, 1015, 1007, ... 55, 43, 31, 9, 2, 1, 0, and you would adjust the controls so a difference between black (0) and the next level (1) is visible. Any departure from this type of setup must be documented. If the display cannot be adjusted to observe the first level above black, then report the first level above black that is visible.





### 301-3b Saturated Color Performance Assessment

Use the color bar pattern to determine the presence of all saturated and primary colors. No measurements are made, so only the presence of the colors is observed, not an assessment of how well the colors are reproduced. The full-screen color bar pattern is intended for visual assessment of the general color performance of a display. All colors are saturated to enable minimum difficulty in visually assessing presence of color and relative saturation as per an adequate color gamut. The full-screen color gamut is measured in section 302-4 (Color Characteristics of Full Screen).

The full-screen color bar pattern (Fig. 1) is a sequence of vertical bars that show the three saturated primary colors, three secondary, black, and white. The color order (from left to right) is white, yellow, cyan, green, magenta, red, blue, and black—this assumes an RGB color scheme. Their order represents video content luminance from maximum on the left, to minimum, on the right. Their heights are full screen with widths of 1/8 of the total horizontal video size.

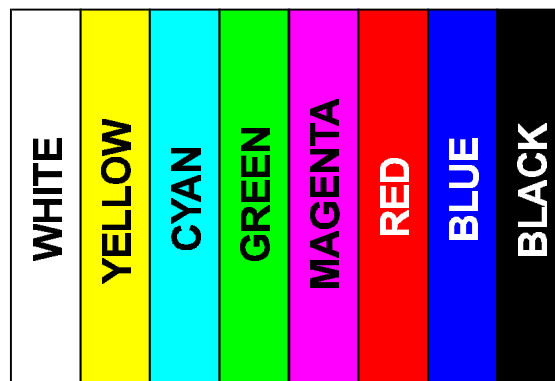


Fig. 1. Color bar pattern from RGB primaries.

Their order represents video content luminance from maximum on the left, to minimum, on the right.

Their heights are full screen with widths of 1/8 of the total horizontal video size.

**Use of Color Bars:** There are a number of uses for which the color bar pattern will serve to check:

- the saturated-color (full gamut) and black-and-white performance of the DUT
- to assure all primary and secondary colors are displayed
- to assure all colors are in the correct order
- of proper signal path arrangement, including wiring and cabling
- the color purity, saturation, and hue
- the spatial color separation
- of signal path performance for adequate color response capability
- to assure that all saturated colors can be displayed without overlap or other spatial degradation
- to assure all colors are distinct from each other
- to assure there are no color dependencies or characteristics of the DUT that vary from one color to another.

**Reporting:** Report in the comments sections of the reporting templates any problems with the appearance of normally displayed color bars, such as missing colors, wrong colors, problems at the transition points between colors, or color artifacts, etc.

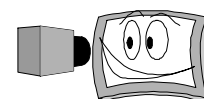
### 301-3c Cosmetic Defect Assessment

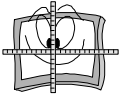
While displaying alternately a white and black full screen, inspect the DUT for cosmetic defects. These are imperfections of the display surface or its packaging that are visible on the external surface that detract from the display's value such as the following examples (not a complete or required list):

- |          |             |            |                         |
|----------|-------------|------------|-------------------------|
| • cuts   | • gouges    | • pullouts | • misalignment of parts |
| • dents  | • scratches | • cracks   | • stains on components  |
| • smears | • bubbles   | • bumps    | • other ...             |

Report description of any unacceptable cosmetic defects on the reporting sheet in the comment section along with any other appropriate information such as position, type of defect, size, and shape. Note: This section does not include pixel defects that are handled separately in section 301-3e nor does it include mura (nonuniformities on the display surface) dealt with in 301-3d.

**Discussion:** This is an example of a characteristic that may or may not exist on a display face or its enclosure. Such defects arise from contamination in the manufacturing process, cuts, scratches, gouges, etc., which could occur in any level of processing or handling of the product. All types of cosmetic defects cannot be easily classified. They vary almost limitlessly in types, characteristics, and conditions, and what is acceptable or not is generally determined in agreements between display manufacturers/handlers and those who integrate them into usable products, such as OEM's. It is beyond the scope of this document to offer a defined procedure of or listing





for cosmetic defects. Other than the general guidelines, cosmetic defect assessment should be done in accordance with agreed upon guidelines between the display supplier and user.

In general, cosmetic defects can be any type of abnormalities found on a display, housing, front of screen, etc. They may be assessed in terms of quantity, size, shape, level of visibility, location, etc. They may or may not degrade the performance and the usability of the display, and how objectionable they are may be related to the area where they are located or their proximity to boundaries on the display or to other defects. For instance, a highly visible cut, gouge, or permanent stain on the face of a display might significantly reduce visibility and reduce the usability of the display, whereas an even worse cut, scratch, etc. on the side or rear of the display would not affect the visible display area at all and might be acceptable. The acceptability of either must be determined by the observer based upon specific criteria from the interested parties.

### 301-3d Mura Assessment

Mura (moo-rah') is a Japanese term meaning nonuniformity and has been adopted in English to provide a name for imperfections of the display pixel matrix surface(s) that are visible when the display is in operation. Inspect the display surface while displaying a white full screen, a black full screen, and a dark gray full screen. Look for any imperfections that interfere with the uniformity of the displayed luminance such as a mottled appearance or bright or dark spots that may be objectionable. This is not attempting to look for large area nonuniformities which will be measured in section 307, but attempts to find any imperfections which are present on the scale of from a few pixels in size to usually less than 20 % of the screen diagonal. Report any findings in terms of size, quantity, position, etc., in the comment section of the reporting sheet. Note: Mura, as we use it here, does not include pixel defects that we detail in 301-3e.

### 301-3e Pixel Defects Assessment

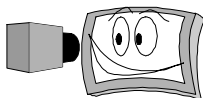
**NOTE:** The tolerance for pixel defects should be negotiated between all interested parties. The pixel defect tolerance depends upon the application of the display, and a general classification scheme cannot cover all specialized uses of displays. A possible method of pixel defect characterization and identification that may be of use to you is presented as a measurement in 303-5 (Pixel Defects). During warm-up is an excellent time to look for bad pixels.

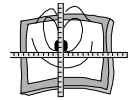
### 301-3f Flicker Visibility Assessment

With a white full screen (or whatever pattern is determined to produce the worst-case flicker) and the DUT in a typical office lighting situation (or the ambient lighting which is characteristic of the environment in which the display will be used), look for flicker from the display surface with the screen in your foveal and then in your peripheral vision. Report any observed flicker and observing conditions on the reporting sheet, e.g., the pattern displayed, the colors employed, size of displayed area, observer viewing angle, if peripheral or foveal vision is used to observe the flicker, ambient lighting, viewing distance, etc.

**Discussion:** Flicker is the visible rapid luminance variations in time having to do with how the screen is driven to produce a static image. Flicker is defined as perceptible rapid temporal luminance variation of a nominally constant-luminance test pattern: Flicker can be analytically measured, as in Section 305, but unless the measured flicker level exceeds the minimum human perception threshold, the DUT cannot be properly be said to be flickering. A number of characteristics affect the perceptibility of flicker: luminance level, frequency, modulation, ambient lighting, displayed area, whether the displayed area is in foveal or peripheral vision. Note that there is a wide variation in observer sensitivity to flicker—flicker may be noticeable to one person but imperceptible to another. Any temporal luminance modulations invisible to all human observers are not of concern here. The presence of visible flicker on a display is generally undesirable, but some level of flicker may be acceptable in certain cases. All interested parties should be in agreement with the acceptability and conditions of visible flicker.

The characteristics that determine the production of flicker will vary from technology to technology. For example, some technologies have little persistence of luminance from frame to frame, and higher vertical refresh





rates (e.g. 76-85Hz, rather than 60Hz) are required to minimize perception of flicker. For such technologies, higher luminance levels increase the perception of flicker, while higher vertical rates reduce it. Other displays have dependencies that can cause flicker at reduced luminance levels and/or reduced refresh rates. This section does not intend to go into great detail about the properties of flicker or visible perception variables. For measurements of flicker see Section 305.

### 301-3g Video and Image Artifacts Assessment

While displaying a variety of full-screens saturated colors, pastels, white, grays, or black, as well as other patterns like checkerboards, grilles, etc.; look for video artifacts such as noise, periodic spatial irregularities (Moiré), or periodic temporal irregularities. Report any inadequacies in the comment section of the reporting sheet.

**DISCUSSION:** Displays can be characterized and measured in every conceivable manner, yet the possibility of some non-quantified visible artifact can still exist. There seem to be an indeterminable number of possibilities on how video artifacts can occur and what their characteristics may be. They may relate to any display anomalies or part of any of the electronics that generate video for the DUT or other sources coupling into the video electronics generation. Non-electronic mechanisms or electronic sources outside of the system to which the DUT belongs may also cause video artifacts. Examples could include magnetic coupling or radio frequency susceptibility. It should be kept in mind that the DUT itself does not have to have susceptibility to such mechanisms, but rather the signal paths in proximity to the DUT, such as a video signal transmission line, could allow for external coupling, and then directly transmit it to the DUT where it might be shown as unwanted video.

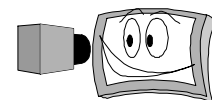
Visible video artifacts can be dynamic, or moving in time incoherently with the video signal. It is also possible to have video artifacts that are stationary or synchronous with the video or part of the video. These video artifacts may also be present on all of the screen or part (or parts) of it, and they might even vary as a function of position. They might also be sensitive to video content, changing or only occurring for certain variations of displayed video. They might be of any size, location, pattern, of any temporal or spatial characteristics, and may occur consistently or may be intermittent, appearing to be entirely random. Due to the potential randomness of such characteristics, it is impossible to produce all situations for the DUT in which artifacts might occur, and there might never be any artifacts in the DUT. Observed video artifacts are often classified as video noise, an unwanted part of the video signal. Whatever the cause, this section permits the documentation of any visual artifact on the DUT. To further complicate matters, subtle artifacts may be perceivable by one observer but be invisible to another.

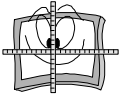
**SETUP:** There is no one best video pattern or condition that should be used to seek video artifacts. The only guidelines that can be given are to use whatever video and external stimuli that may be useful, typical, or practical to implement. Basic operation for observing video artifacts would include starting testing by using patterns such as all white, all black, fine checkerboards (down to alternating black-white pixels), vertical lines, horizontal lines, and variations of color (both saturated and pastel) and gray-scale content and position.

**PROCEDURE:** Using any number of different patterns, vary any condition of the DUT to observe video artifacts. Vary any external stimuli as appropriate and with minimal risk of damage to the system. Some examples of external stimuli (use with caution) might be movement of video lines (if accessible), variation of the power source within its tolerance limits (if accessible), movement of the DUT, lightly nudging connectors, variation of any controls like brightness or contrast, etc.

**REPORTING:** Any pattern, condition, or external stimulus that induces, changes, or eliminates video artifacts should be reported. Also, report the description and any other pertinent characteristics of any perception of video noise on the reporting sheet. Other characteristics may include size, duration, position, or persistence of the disturbance. Report any artifact observations in the comment section of the reporting form.

**COMMENT:** See 306-6 Anomalous Nonuniformity for a specific measurement example.



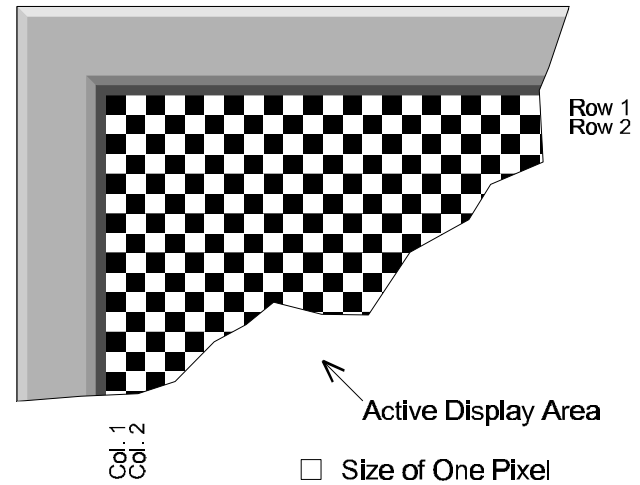


### 301-3h Alternating-Pixel Checkerboard Testing

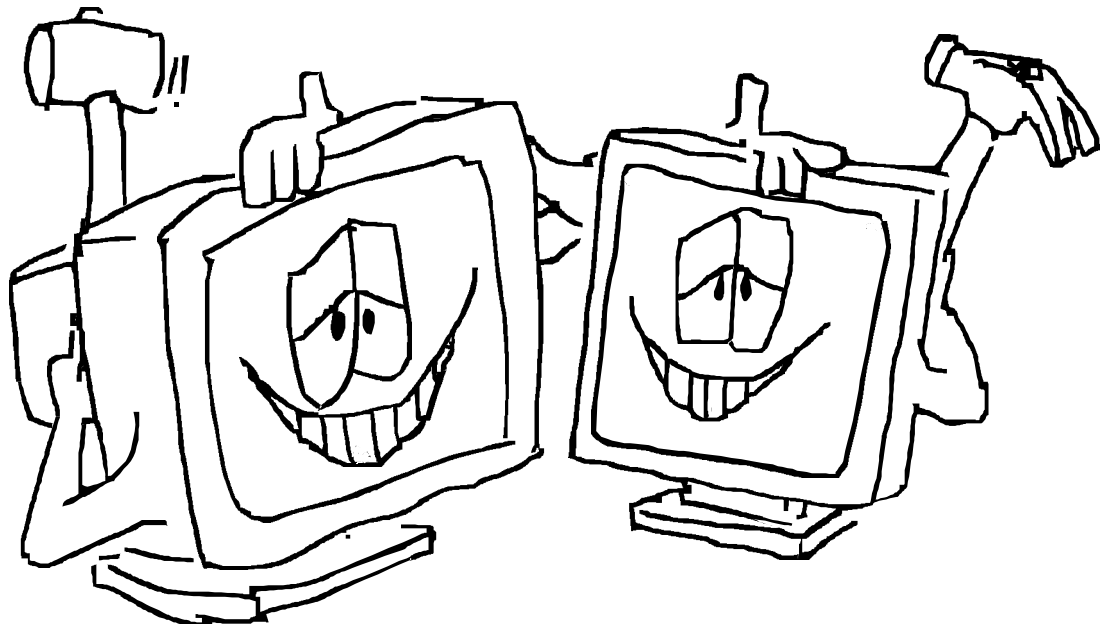
Display an alternating-pixel checkerboard pattern and look for clarity of black and white individual pixels. If the black pixels are gray or the white pixels are noticeably gray or both, it could indicate problems in some of the circuits or the generating signal. Report any inadequacies in the Comments Section of the reporting form.

**DISCUSSION:** An alternating pixel pattern is a series of on-off-on-off... pixels (e.g. white-black-white-black...) where each successive row is the inverse of the row above it. Such a pattern is the same as a checkerboard pattern in which the size of the checkers is reduced to one pixel. A compliment or inverse alternating pixel display may also be used whereby the two patterns can be compared.

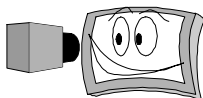
The alternating pixel patterns produces the highest frequency video, and pixel clarity on the DUT is representative of the display's ability to reproduce the highest frequency video signal. Such a pattern tests the DUT sensitivity to rise/fall times and frequency capabilities of the video system (generated video and transmission path). Some find that this pattern also enables them to check for pixel defects as well; any pixel which is continually fixed at a certain luminance level or color will often stand out better when observed surrounded by all black or white pixels.

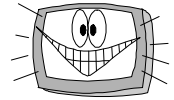


*Fig. 1. Alternating pixel pattern.*



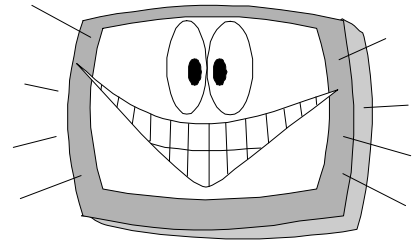
**BUDDIES!**





## 302 CENTER MEASUREMENTS OF FULL SCREEN

Measurements are made on the center screen while a full-screen of white, black, gray, or color is displayed. The methods for the full-screen measurements specified in this section (302-1, -2, -4, -5, -6, -7) are essentially identical except for the selected color to be used over the entire screen (white, black, grays, primary or secondary colors, or other colors). The light measuring device (LMD) need only be set up once and measurements taken of the various full-screens. The determination of the full-screen contrast ratio amounts to a calculation using the results of full-screen-white and full-screen-black measurements.



In general we specify that only one measurement need be made. The reason that the averages of multiple measurements are generally not necessary is that the repeatability of the light measuring device (LMD) is usually a factor of ten or more better than its measurement uncertainty. Good metrology would dictate that the user of the LMD be acquainted with the instrument and that the instrument be tested with the DUT to be sure that proper measurements are being made. We suggest that with a full-screen white a series of measurements be made and compared to assure that there is good repeatability within the precision requirements of this standard, namely, that the repeatability of the measurement (301-2k Luminance Measurement Repeatability) is less than twice the required maximum repeatability of the LMD for this document ( $2s_{LMD} = 0.5\%$ ).

It should be noted that glare from a lens used in the detector can corrupt all luminance measurements, even white. Diagnostics can be performed to illustrate the existence of glare light and possibly make a correction for it, however, the best way to eliminate glare effects is to use a mask, in particular, a black-gloss-cone mask. See the Metrology Section: Veiling Glare and Lens Flare Errors (A101) for details on glare effects and appropriate diagnostics.

### THE FOLLOWING MEASUREMENTS ARE SPECIFIED:

The following measurements differ in only requiring a change in screen color (including black, white, and grays).

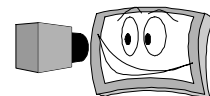
- 302-1 LUMINANCE OF FULL-SCREEN WHITE**
- 302-2 LUMINANCE OF FULL-SCREEN BLACK**
- 302-3 CONTRAST RATIO OF FULL SCREEN**
- 302-4 GAMUT AND COLORS OF FULL SCREEN**
- 302-5 GRAY SCALE OF FULL SCREEN**
- 302-6 COLOR SCALES OF FULL SCREEN**
- 302-7 COLOR CHANGES WITH GRAY SCALE**

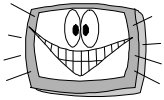
The following measurement specifies an adjustment of controls. It may be best if this measurement be performed before final adjustment is made on the display during setup or be made after all other measurements have been completed:

- 302-8 LUMINANCE ADJUSTMENT RANGE**

The following measurement can be complicated and time consuming if not automated:

- 302-9 LUMINOUS FLUX**





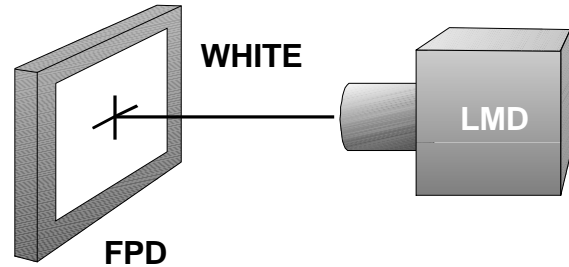
**302-1 LUMINANCE AND COLOR OF FULL-SCREEN WHITE**

(brightness\*, white screen, screen brightness\*)



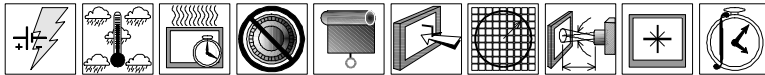
**DESCRIPTION:** We measure the luminance and optionally the chromaticity coordinates (also optionally the correlated color temperature [CCT]) of full-screen white at the center of the screen. **Units:** cd/m<sup>2</sup>, none for chromaticity coordinates, K for CCT. **Symbols:**  $L_w$ ,  $x_w$ ,  $y_w$ , none for CCT.

The luminance of full-screen white (the screen’s “brightness”) is one of the most important metrics for a display and is used for several other measurements and calculations.



**SETUP:** Display a white full-screen test pattern. See Section 301 for any standard setup details.

**SPECIFIC:** Full screen white (see Fig. 1)



**PROCEDURE:** Measure the center-screen luminance and optionally the chromaticity coordinates (also optionally the CCT) of full-screen white subject to above set-up conditions.

**ANALYSIS:** None. If you have made several measurements, you may calculate the mean values for full-screen white.

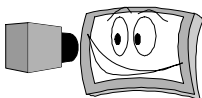
**REPORTING:** Report the luminance (optionally the chromaticity coordinates) of full-screen white to no more than three significant figures. If the CCT is measured it may be reported to four significant figures. If you have made several measurements, you may report the mean values.

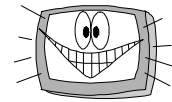
**COMMENTS:** If you haven’t already tested the uncertainty in the luminance measurement, now is a good time to do it; see sections Adequate Integration Time (301-2j) and Luminance Measurement Repeatability (301-2k) for instructions. Bear in mind that all the full-screen measurements are made with the same equipment configuration. To calculate the uncertainties associated with this measurement, see A108 Uncertainty Evaluations.

Reporting Results - Sample Data			
Full Screen Center Performance			
	L (cd/m <sup>2</sup> )	CIE x	CIE y
White	43.9	0.277	0.285
Black	0.381	0.247	0.242
$C_R$	293	No Units for $C_R$	
Red	26.93	0.594	0.319
Green	56.17	0.299	0.606
Blue	12.0	0.145	0.068

\* Note: Luminance and brightness are not the same thing. Two colors can appear to have the same brightness and exhibit different luminances. Brightness—a colloquial technical term—should not be used synonymously with luminance. We include it here because of tradition and history. See Glossary and A201.

OPTICAL





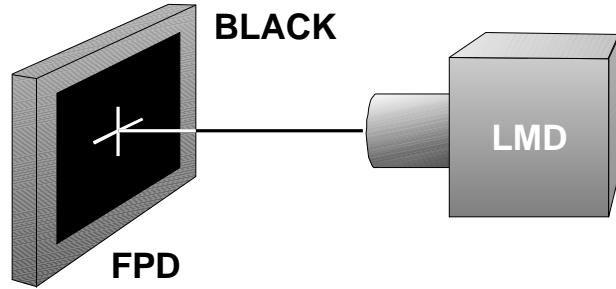
## 302-2 LUMINANCE AND COLOR OF FULL-SCREEN BLACK

(black screen, black viewing surface, entire screen black)



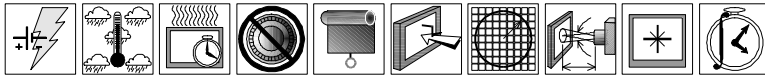
**DESCRIPTION:** We measure the luminance and optionally the chromaticity coordinates of full-screen black at the center of the screen. **Units:**  $\text{cd/m}^2$ , none for chromaticity coordinates. **Symbols:**  $L_b, x_b, y_b$ .

How dark the black screen is can greatly affect the contrast and image quality of a display. When images are displayed, the eye will often appreciate darker blacks and higher contrasts that approach what is observed in real scenes, especially as the solid angle of any black area increases.



**SETUP:** Display a black full-screen test pattern. See Section 301 for any standard setup details.

**SPECIFIC:** Full screen black test pattern



**PROCEDURE:** Measure the center-screen luminance and optionally the chromaticity coordinates of full-screen black subject to above set-up conditions.

**ANALYSIS:** None. If you have made several luminance measurements, you may calculate the mean value as the luminance of full-screen black.

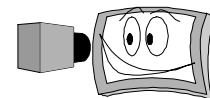
**REPORTING:** Report the luminance and optionally the chromaticity coordinates of full-screen black to no more than three significant figures. If you have made several measurements, you may report the mean values.

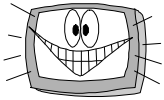
**COMMENTS:** Luminance and especially chromaticity coordinate measurements of dark objects can be difficult. Dirt, scratches, or dust on the display surface can affect the black measurement especially if the display technology has a large change in luminance with viewing angle. Keep in mind that for some technologies the establishment of the perpendicular (or the design viewing direction) can be very critical to the measurement of black. Any off-perpendicular measurement of black should be agreed upon and clearly stated in all documentation and reporting. If off-perpendicular black is permitted, a normal black should be measured as well.

The uncertainties in the luminance and chromaticity coordinates are essentially the uncertainties associated with the LMD. The measurement of black quantities is often subject to significant errors. Factors that contribute to the measurement of black are the uncertainty of the instrument, the repeatability, and the digitizing error (as in  $\pm 1$  digit in the last place of a digital readout device). To calculate the uncertainties associated with this measurement, see A108 Uncertainty Evaluations.

Reporting Results - Sample Data			
Full Screen Center Performance			
	L ( $\text{cd/m}^2$ )	CIE x	CIE y
White	43.9	0.277	0.285
Black	0.181	0.247	0.242
$C_R$	233	No Units for $C_R$	
Red	26.93	0.594	0.319
Green	56.17	0.299	0.606
Blue	12.0	0.145	0.068

OPTICAL





### 302-3 CONTRAST RATIO OF FULL SCREEN

(contrast, full-screen contrast, full-screen contrast ratio, maximum contrast)



**DESCRIPTION:** We calculate the contrast ratio of full-screen white and black. **Units:** none, a ratio; **symbol:**  $C_R$ .

The full-screen contrast ratio is probably the second most notable metric for displays other than the luminance of full-screen white. A display with high contrast capabilities is often better able to create more realistic images and to provide better readability; especially when the black or dark regions of the image constitute a substantial amount of the screen surface in which case the eye appreciates the greater contrast. The full-screen contrast ratio is the most simple and reproducible contrast measurement to make.

**SETUP:** None. Measurements of full-screen white and black are made previously (302-1 and 302-2).

**PROCEDURE:** None. Measurements of full-screen white and black are made previously (302-1 and 302-2).

**ANALYSIS:** Calculate the contrast ratio  $C_R = L_w / L_b$ .

**REPORTING:** Report the contrast ratio to no more than three significant figures using the values for  $L_w$  and  $L_b$  obtained in the previous sections. Report as a single number with or without a colon, such as “232” or “232:1”.

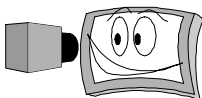
**COMMENTS:** The contrast ratio of a display is very sensitive to an accurate black measurement. To calculate the uncertainties associated with this measurement, see A108 Uncertainty Evaluations.

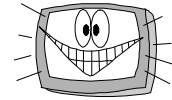
Reporting Results - Sample Data			
Full Screen Center Performance			
	L (cd/m <sup>2</sup> )	CIE x	CIE y
White	43.9	0.277	0.285
Black	0.18	0.247	0.242
$C_R$	243	No Units for $C_R$	
Red	26.93	0.594	0.319
Green	56.17	0.299	0.606
Blue	12.0	0.145	0.068

**NOTE:** The full-screen contrast ratio is the contrast metric that is always assumed unless specified otherwise for direct-view display technologies (not necessarily projection systems or any display that places a lens between the pixel surface and the viewed image—head-mount, head-up, etc.). Any other contrast metric must be properly identified explicitly if it is not this full-screen contrast ratio. We strongly suggest the above  $C_R$  in any characterization of direct-view displays. If a non-perpendicular viewing angle is used it must be reported with the contrast value.

For example, if someone simply says that the contrast of their display is such-and-such, it must be referring to the full-screen  $C_R$  above. If a box contrast is used then it must be stated “the box contrast is...,” similarly for a  $4 \times 4$  checkerboard contrast, “the  $4 \times 4$  checkerboard contrast is...” In any case we strongly suggest that the above  $C_R$  always be reported.

If a viewing angle is employed such as  $4^\circ$  up vertically and  $C_R = 400$  whereas  $C_R = 250$  for the perpendicular we report as “The viewing contrast at  $4^\circ$  vertically up from perpendicular is 400:1,” or “400:1 at  $4^\circ$  up.” If the contrast at perpendicular is also included, state it clearly: “The contrast at the perpendicular is 250:1,” or “250:1 at  $0^\circ$ .”



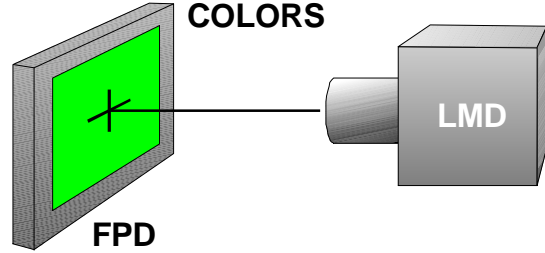


# 302-4 GAMUT AND COLORS OF FULL SCREEN

(gamut, display gamut, screen gamut)



**DESCRIPTION:** We measure the luminance and chromaticity coordinates (gamut) of the full-screen primary (optionally secondary) colors at the center of the screen. Optionally, it may be useful to measure selected colors specified by certain signals (analog or digital) to measure how the color is rendered by the display. **Units:**  $\text{cd/m}^2$  for luminance, no units for chromaticity coordinates.

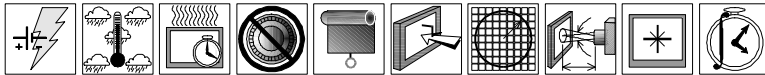


**Symbols:**  $L_{red}, L_{gm}, L_{blu}, x_{red}, y_{red}, x_{gm}, y_{gm}, x_{blu}, y_{blu}$  for primary colors (optionally for secondary colors,  $L_{cyn}, L_{mag}, L_{yel}, x_{cyn}, y_{cyn}, x_{mag}, y_{mag}, x_{yel}, y_{yel}$ ).

The size of the color gamut affects the range and saturation of displayed colors. The location of the most saturated primary colors within the color space identifies the size and shape of the gamut of possible colors within the color space. Certain other colors may be important for specific tasks (see Comments).

**SETUP:** Display a colored full-screen test pattern. See Section 301 for any standard setup details.

**SPECIFIC:** Full screen primary (optionally secondary or other) colors



**PROCEDURE:** Measure the center-screen luminance and chromaticity coordinates of the full-screen primary colors (optionally secondary colors) subject to above set-up conditions. Optionally, measure selected colors within the gamut.

**ANALYSIS:** None. If you have made several measurements, you may calculate the mean values.

**REPORTING:** Report the luminance and chromaticity coordinates of all the full-screen primary (optionally secondary or other) colors to no more than three significant figures. If you have made several measurements, you may report the mean values.

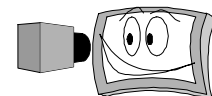
**COMMENTS:** The 1931 CIE chromaticity coordinates are noted here. However the use of the 1976 CIE ( $u', v'$ ) chromaticity coordinates is encouraged, see Photometry and Colorimetry (A201) for details. To calculate the uncertainties associated with this measurement, see A108 Uncertainty Evaluations.

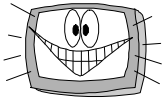
Note: For any DUT the color gamut should be measured. The SBM calls only for the luminance and chromaticity coordinates for the primary colors.

**Other Colors:** Some selected colors may be of particular interest, such as flesh tones, fabric colors, biological tissue colors, paints, foliage, blue sky, etc. These colors might be specified by a certain analog or digital signal. The signal is intended to produce a specific color. For some applications, how accurately the display can produce the color may be important. The same procedure is used for all full-screen colors.

Reporting Results - Sample Data			
Full Screen Center Performance			
	L ( $\text{cd/m}^2$ )	CIE $x$	CIE $y$
White	43.3	0.277	0.285
Black	0.181	0.247	0.242
$C_R$	243	No Units for $C_R$	
Red	26.9	0.594	0.319
Green	56.2	0.299	0.606
Blue	12.0	0.145	0.068

OPTICAL





## 302-5 GRAY SCALE OF FULL SCREEN

(gamma, electro-optical transfer function)



**DESCRIPTION:** We measure the luminances of eight (optionally 16) full-screen gray levels at the center of the screen. **Units:**  $\text{cd}/\text{m}^2$  no units for gamma ( $g$ ). **Symbol:** None for luminance levels,  $g$  for the gamma value.

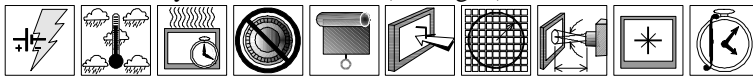
Gray levels are generated by the voltages from a signal generator or are specified by the bit level in a software program as with the display with a computer. These input levels to the screen produce different luminance values on the DUT. The relationship between the luminance and the specified gray level has a large effect on the quality of displayed pictures and images.

**SETUP:** Display each of eight (optionally 16) full-screen gray test patterns from black to white and arrange the luminance meter to measure the luminance at screen center. The signal levels or bit levels producing the gray levels are evenly spaced from the level producing white to the level producing black. In order to select the appropriate gray level from a large set of available gray levels, use one of the following models:

**Bit Levels in Software:** Given  $n$  levels of gray that can be displayed on a screen, with 0 for black and  $w = n - 1$  for white. We want to select a subset of  $m$  levels that are as evenly spaced as possible. The interval between the  $n$  levels to create  $m$  levels is  $\Delta V = w/(m-1)$ , which may not be an integer. So, the levels to select are the (integer) values of  $V_i = \text{int}[(i-1)\Delta V]$  for  $i = 1, 2, \dots, m$ , or  $V_i = 0, \text{int}(\Delta V), \text{int}(2\Delta V), \dots, \text{int}[(m-1)\Delta V]$ , with  $\text{int}[(m-1)\Delta V] = w$  for white. For example, if there are  $n = 256 = 2^8$  levels from which we select  $m = 8$  levels, white is  $w = 255$ ; the interval is  $\Delta V = 36.4286$ , and the chosen levels are: 0, 36, 73, 109, 146, 182, 219, 255.

**Analog Signal Levels:** For analog signals, if  $V_w$  is the white level and  $V_b$  is the black level, then for  $m$  levels the signal step size is  $\Delta V = (V_w - V_b)/m$  and  $V_j = V_b + j\Delta V$ .

**SPECIFIC:** Gray levels full screen (see Fig. 1). See Section 301 for any standard setup details.

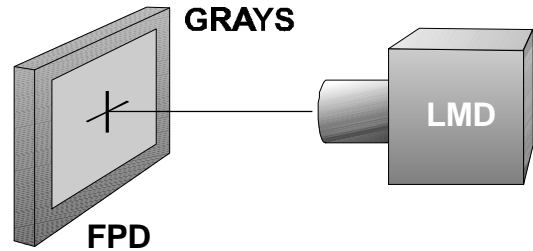


**PROCEDURE:** Measure the center-screen luminance of each of the eight (optionally 16) gray levels including white and black subject to above set-up conditions.

**ANALYSIS:** None.

**REPORTING:** Report the luminances of the full-screen gray levels to no more than three significant figures.

**COMMENTS: NOTE:** For special purposes it may be useful to explore more than eight or 16 levels. It may be necessary to explore all the levels of gray from black to white or any segments in that scale. For example, it may be useful to examine the first 10 levels from black and the last 10 levels to white. This procedure can easily be extended to provide such a detailed coverage of the gray scale.



The relationship between the luminance and the specified gray level has a large effect on the quality of displayed pictures and images.

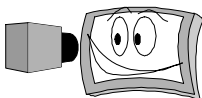
The signal levels or bit levels producing the gray levels are evenly spaced from the level producing white to the level producing black. In order to select the appropriate gray level from a large set of available gray levels, use one of the following models:

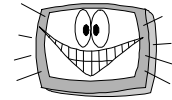
Given  $n$  levels of gray that can be displayed on a screen, with 0 for black and  $w = n - 1$  for white. We want to select a subset of  $m$  levels that are as evenly spaced as possible. The interval between the  $n$  levels to create  $m$  levels is  $\Delta V = w/(m-1)$ , which may not be an integer. So, the levels to select are the (integer) values of  $V_i = \text{int}[(i-1)\Delta V]$  for  $i = 1, 2, \dots, m$ , or  $V_i = 0, \text{int}(\Delta V), \text{int}(2\Delta V), \dots, \text{int}[(m-1)\Delta V]$ , with  $\text{int}[(m-1)\Delta V] = w$  for white. For example, if there are  $n = 256 = 2^8$  levels from which we select  $m = 8$  levels, white is  $w = 255$ ; the interval is  $\Delta V = 36.4286$ , and the chosen levels are: 0, 36, 73, 109, 146, 182, 219, 255.

For analog signals, if  $V_w$  is the white level and  $V_b$  is the black level, then for  $m$  levels the signal step size is  $\Delta V = (V_w - V_b)/m$  and  $V_j = V_b + j\Delta V$ .

See Section 301 for any standard setup details.

Reporting - Sample Data	
Gray-scale luminance	
Level	Lum.
White (7)	106
Level 6	81.3
Level 5	55.6
Level 4	33.6
Level 3	17.4
Level 2	7.14
Level 1	1.68
Black (0)	0.084





### 302-5a Determination of “Gamma”

**DESCRIPTION:** We determine the electro-optical transfer function (“gamma”) for the previous data taken in 302-5 Gray Scale of Full Screen. **Units:** no units for gamma ( $g$ ). **Symbol:**  $g$

When the gray scale of a display can be mathematically characterized by a power-law of the input signal, then it is often useful to extract the value of that power  $g$ .

**ANALYSIS:** As in Fig. 2 and the sample analysis table, plot the log of the net luminance  $L - L_b$  where  $L_b$  is the luminance of black against the log of the gray level bit value (or signal level)  $V$ . Establish the slope of the line best fitting the log-log data. (We are using “log” to mean  $\log_{10}$ , “ln” will be used for natural logs.) Use linear regression if possible or graphical techniques if you must. The slope of this log-log graph is historically referred to as the “gamma” based on the mathematical model for the luminance defined below (see Comments Section below).

**REPORTING:** Report the gamma value to no more than three significant figures.

**COMMENTS:** Some may argue that a nonlinear fit to the luminance data would provide a better model, whereas here we specify a fit to the log-log data. The eye is relatively insensitive to small changes in the higher luminance levels but is very sensitive to changes in the lower luminance levels. Fitting to the log-log data can give a better fit to the lower luminance levels when using some commercial software packages, and most are more comfortable with the ease-of-use of the log-log slope extraction. By virtue of requiring a fit to the data, you obtain the values for parameters specifying the fit function from the fitting routine. The line in Fig. 1 is a nonlinear fit to the luminance data providing a gamma of  $g = 2.05$  using the model:

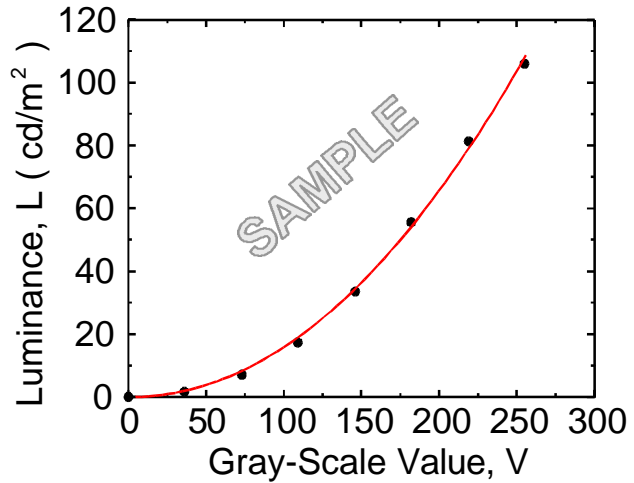


Fig. 1. Sample Luminance vs. gray scale (using a 256 bit gray scale).

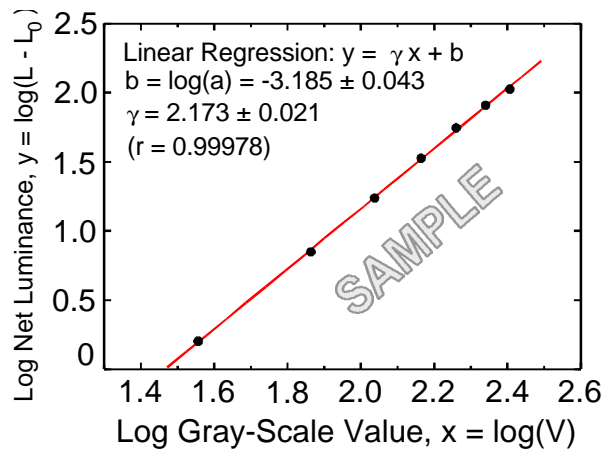


Fig. 2. Sample Log-log plot of luminance vs. gray scale.

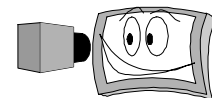
$$L = aV^g + L_b, \tag{1}$$

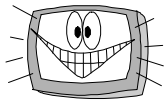
or in terms of logs,

$$\log(L - L_b) = g \log(V) + \log(a) . \tag{2}$$

Here the parameters  $a$  and  $g$  relate the signal level  $V$  to the luminance  $L$ . The gamma we calculate from the log-log representation (Fig. 2) of the data is  $g = 2.17$ . To plot the log-log model result using 2.17 for gamma in Fig. 1 would almost overlay the drawn curve, however, there would be a slightly better fit to the lower luminance values which would be hard to see on this scale.

Many display technologies will assume that a linear signal (either an analog signal or bit-level specification)  $V$  will produce a nonlinear luminance  $L$  according to some model like Eq. (1). The nonlinear luminance, however, appears linear to the eye because the eye is a nonlinear detector (see A209) as is the ear. The model expressed by Eq. (1) is not necessarily a rigorous model. For example, in television, there may be a linear component substituted for low-level signals (e.g.,  $V_w/10$  or smaller). See, for example, SMPTE Standard 170M, Composite Analog Video Signal—NTSC for Studio Applications. [5] There may also be gray-scale





Analysis - Sample Data					
Level	Scale V	Lum. L	Net Lum. $L-L_b$	Log Scale $\log V$	Log Net. Lum. $\log(L-L_b)$
White (7)	255	106	105.9	2.4065	2.0250
Level 6	219	81.3	81.2	2.3404	1.9096
Level 5	182	55.6	55.5	2.2601	1.7444
Level 4	146	33.6	33.5	2.1644	1.5253
Level 3	109	17.4	17.3	2.0374	1.2385
Level 2	73	7.14	7.06	1.8633	0.8486
Level 1	36	1.68	1.60	1.5563	0.2030
Black (0)	0	0.084	$= L_b$		
Gamma from log-log plot (lin. fit)				2.17	

Reporting - Sample Data	
Gray-scale luminance	
Level	Lum.
White (7)	106
Level 6	81.3
Level 5	55.6
Level 4	33.6
Level 3	17.4
Level 2	7.14
Level 1	1.68
Black (0)	0.084
Gamma	2.17

behavior that does not readily follow the simple model of Eq. (1)—see Fig. 3. In such cases it may not be appropriate to determine a gamma value. Some gray-scales follow a gamma-type behavior for moderate to high luminances but deviate from the model for low luminances. Other types of displays, e.g., LCDs, may follow a gamma-type behavior for low and middle luminance levels but deviate from the model for the higher luminances. In such cases whether or not a gamma value is determined using only the data for which the model fits depends upon the needs of those who are using the display. If a gamma value is calculated and reported for data that do not fit our simple model well it should be noted in the comments of a report form. If not all the data are used to calculate a gamma then what data are used to calculate the gamma value should be reported. Here, we would suggest that an adequate fit to the model is obtained whenever the correlation coefficient  $|r| \geq 0.98$ , otherwise the correlation coefficient should be reported.

In Fig. 3 we show an example of a LCD where the curve flattens out as the luminance reaches the white level. We might be tempted to refrain from determining a gamma value from such data since it doesn't fit a straight line in log-log space very well. However, if we were to fit these log-log data to a straight line, we would obtain a fit result with a correlation coefficient above 0.98. This shows that  $|r| \geq 0.98$  can constitute a rather sloppy fit. Whether or not to use such a simplistic linear fit method to such data should be determined by all interested parties. Perhaps there is another fitting function that is more suitable and nonlinear regression methods would provide results that are more useful.

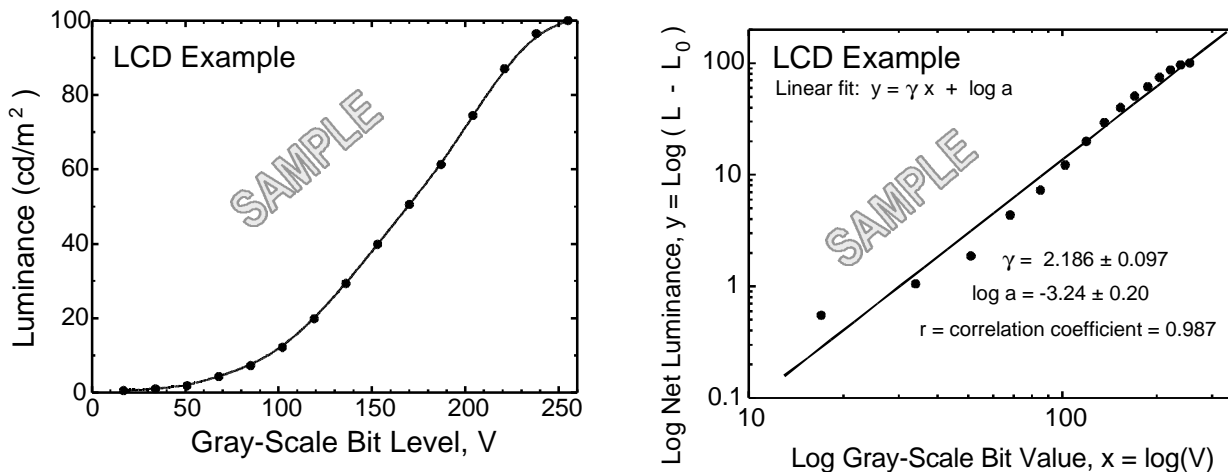
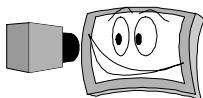
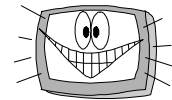


Fig. 3. Example of the electro-optical transfer function for a liquid crystal display where the curve flattens out near the white level. The right figure shows a linear fit to these data.





## 302-6 COLOR SCALES OF FULL SCREEN

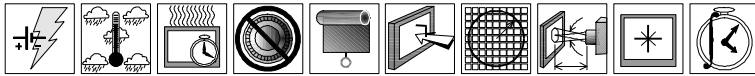
(color gammas, electro-optical transfer functions for colors)

**DESCRIPTION:** We measure the luminance scale of the primary (optionally secondary) colors as eight (optionally 16) full-screen color levels go from highest luminance of the color to black and optionally calculate a “gamma” value for each color. **Units:**  $\text{cd}/\text{m}^2$ , no units for gammas. **Symbol:** None for luminance levels,  $g_{\text{color}}$  (e.g.  $g_{\text{red}}$ ,  $g_{\text{em}}$ ,  $g_{\text{lu}}$ , for RGB) for gamma values.

Color levels like gray levels are generated by the voltages from a signal generator or are specified by the bit level in a software program as when the display is part of a computer. This measurement procedure is similar to the 302-5 Gray Scale of Full Screen procedure, refer to it for more details, plots of data, an example of analysis, and an example of reporting.

**SETUP:** Display each of eight (optionally 16) full-screen color test patterns from black to the highest color luminance and arrange the luminance meter to measure the luminance at screen center. This should be done for each primary (optionally secondary) color. The signal levels or bit levels producing the color levels are evenly spaced from the level producing highest color luminance to the level producing black. In order to select the appropriate color level from a large set of available color levels, use one of the models outlined in 302-5.

**SPECIFIC:** Color levels full screen (see Fig. 1).



**PROCEDURE:** Measure the center-screen luminance of each of the eight (optionally 16) color levels including the highest color luminance and black subject to above set-up conditions.

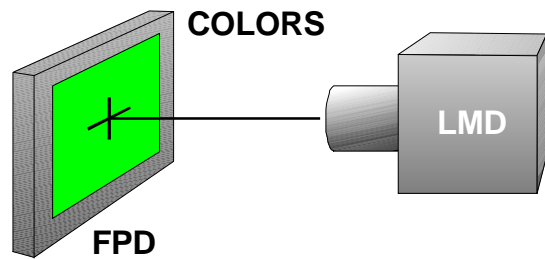
**ANALYSIS:** No analysis is needed if gamma values are not required. Plot the log of the color level bit value (or signal level)  $V$  against the log of the net color luminance  $L - L_b$ , where  $L_b$  is the luminance of black. Establish the slope of the line best fitting the log-log data. Use linear regression if possible or graphical techniques if you must. The slope of this log-log graph is historically referred to as the “gamma” based on the mathematical model for the luminance:  $L = aV^g + L_b$ . See 302-5 for any details.

**REPORTING:** Report the luminances of the full-screen color levels to no more than three significant figures for each primary color. Optionally report the gamma value.

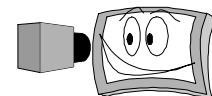
**COMMENTS:** There may be color-scale behavior which does not readily follow the simple model  $L = aV^g + L_b$ . In such cases it would not be appropriate to determine a gamma value. See 302-5 Gray Scale of Full Screen for a more complete discussion of gamma. The uncertainties in the luminance and chromaticity coordinates are essentially the uncertainties associated with the LMD—see A108 Uncertainty Evaluations.

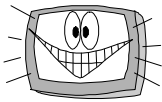
**NOTE:** For special purposes it may be useful to explore more than eight or 16 levels of a particular primary or secondary color.

**NOTE Other Colors:** Colors that fall inside the color gamut of the display are mixes of the primaries (secondary colors fall approximately on the gamut lines and are not considered interior colors). Except for white, all the interior colors use intermediate levels of at least one of the primaries. If more than one level of a certain color is required, the model used to mix the levels of the primary colors in order to define that special color scale must be determined to the satisfaction of all interested parties. The above specification for bit levels in software or analog signal levels does not apply to interior colors except for white. The above measurement procedure can easily be extended to accommodate these special requirements.



OPTICAL





## 302-7 FULL-SCREEN GRAY-SCALE COLOR CHANGES

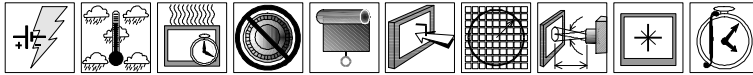
(gray color shift, color temperature shift, color tracking)

**DESCRIPTION:** We measure the color change as eight (optionally 16) full-screen gray levels go from white to black by either the maximum correlated color temperature (CCT) shift or the maximum  $\Delta u'v'$  color metric or both. **Units:** K for CCT, none for the color metric. **Symbol:** none.

Color shifts that occur as grays darken and approach black can be observed in a number of display technologies. Often this is not a problem, but for some applications this phenomena can affect the usefulness of the display.

**SETUP:** Display each of eight (optionally 16) full-screen gray test patterns from black to white and arrange the colorimeter to measure the luminance and chromaticity coordinates at screen center. The signal levels or bit levels producing the gray levels are evenly spaced from the level producing white to the level producing black. For more details about the gray level see a previous measurement Gray Scale of Full Screen (302-5) in this section. . See Section 301 for any standard setup details.

**SPECIFIC:** Gray levels full screen (see Fig. 1).

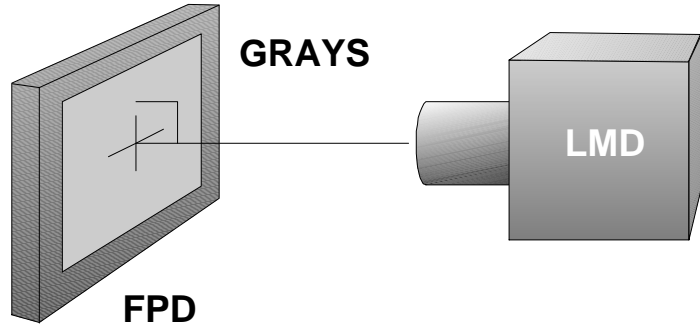


**PROCEDURE:** Measure the luminance and chromaticity coordinates at screen center for each of the eight (optionally 16) gray levels.

**ANALYSIS:** Calculate the color difference between each gray level and white full screen according to (see A201 for a discussion of this color metric):  $\Delta u'v' = \sqrt{(u'_w - u')^2 + (v'_w - v')^2}$ . It may be useful to identify the maximum color difference and calculate the average color difference for reporting.

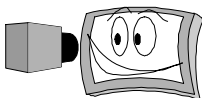
**REPORTING:** Depending upon the needs, the largest color difference might be reported, the average color difference, or the entire table of color differences.

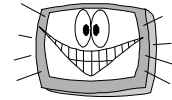
**COMMENTS:** All these eight (or 16) gray or color level measurements from this and any previous measurements can be combined into one table for reporting convenience. For a discussion of the  $\Delta u'v'$  color metric, see A201, Photometry and Colorimetry Summary. Another color-difference metric may be used instead of  $\Delta u'v'$ . Be sure to note which metric is used in any reporting document. To calculate the uncertainties associated with this measurement, see A108 Uncertainty Evaluations.



Analysis – Sample Data						
Level	V	x	y	u'	v'	$\Delta u'v'$
White (7)	255	0.3127	0.3291	0.1978	0.4684	-
Level 6	219	0.3165	0.3289	0.2005	0.4688	0.0028
Level 5	182	0.3239	0.3279	0.2061	0.4694	0.0083
Level 4	146	0.3365	0.3264	0.2156	0.4705	0.0179
Level 3	109	0.3532	0.3211	0.2298	0.4701	0.0321
Level 2	73	0.3719	0.3039	0.2520	0.4633	0.0544
Level 1	36	0.4027	0.2807	0.2896	0.4541	0.0929
Black (0)	0	0.4513	0.2524	0.3522	0.4431	0.1564
Maximum color shift ( $\Delta u'v'$ )					0.1564	
Average color shift					0.0521	

Reporting Sample Data	
Gray-scale luminance	
Level	$\Delta u'v'$
White (7)	$= L_w$
Level 6	0.0028
Level 5	0.0083
Level 4	0.0179
Level 3	0.0321
Level 2	0.0544
Level 1	0.0929
Black (0)	0.1564
Maximum $\Delta u'v'$	0.1564
Average $\Delta u'v'$	0.0521





## 302-8 LUMINANCE ADJUSTMENT RANGE

(brightness range, dimming range, percent of luminance variation, dimming ratio)

**NOTE:** Adjustment of controls can possibly invalidate all previous measurements. We suggest that you perform this measurement during setup (but after warm-up) or make it the last measurement made. If additional luminance (or color) measurements are to be made, the display must be returned to its proper setup configuration for normal operation under standard conditions.

**Note:** This section applies only for displays that have luminance adjustment capabilities. Luminance adjustment may be implemented in various ways (via software control or in hardware), such as by a potentiometer, or by digitally interfaced implementations, such as use of keyboard keystrokes.

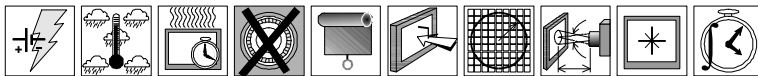
**DESCRIPTION:** Here we measure the luminance adjustment range from maximum and minimum luminance (if such an adjustment is provided) using the center measurement of a white full screen. **Units:** none, expressed in percent. **Symbol:** none.

The luminance adjustment range is the extent to which the full-screen white luminance of a DUT may be adjusted between maximum and minimum brightness with the gray-scale capability preserved as per the setup gray scale (32 gray levels, or however many gray scales agreed upon by all interested parties).

**SETUP:** Display full-screen white during the test. For displays having additional adjustments that can affect the luminance adjustments, the contrast should be pre-adjusted as per the setup section 301-3, and should not be touched during this measurement. However, certain displays are deliberately adjusted to retain the gray scale while the luminance of the full-screen white is adjusted (such as CRT displays used in varied environments). If such a gray-level preservation adjustment is made, it must be fully described in the reporting document. On some displays, the controls can be manipulated to, in effect, turn the display off so that  $L_{\min} < L_b$ . We specify that  $L_{\min}$  must be the minimum luminance without turning the display off. The gray scale must be preserved for all luminance levels employed for the defined task.

**Note:** If other measurements must be made after this test it is important to document the control settings prior to adjustment by whatever mechanical or software method available as well as a luminance measurement of the gray scale, so that the DUT can be returned to the luminance and gray scale it exhibited before this measurement. See Section 301 for any standard setup details.

**SPECIFIC SETUP:** Center measurement of full-screen white.



**PROCEDURE:** Record the maximum luminance on the reporting sheet ( $L_{\max}$ ). Adjust luminance for minimum.

Allow for luminance stabilization as per the standard warm-up time (20 min), then measure luminance.

Report this number as minimum luminance level ( $L_{\min}$ ).

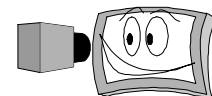
**ANALYSIS:** The Adjustment range is the percentage of reduction of luminance from maximum to minimum luminance. It can be calculated as follows.

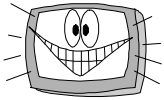
$$\% \text{ Adjustment} = 100\% \frac{L_{\max} - L_{\min}}{L_{\max}}$$

Where % Adjustment = the Luminance Adjustment Range,  $L_{\max}$  = maximum luminance, and  $L_{\min}$  = minimum luminance.

**REPORTING:** Report maximum luminance level ( $L_{\max}$ ), minimum luminance level ( $L_{\min}$ ), then calculate and report Luminance Adjustment Range (% Adjustment). For example, for a DUT that has maximum luminance of 200 cd/m<sup>2</sup> and minimum luminance of 20 cd/m<sup>2</sup>, the adjustment range is 90 %.

**COMMENTS:** On many technologies, it is important to allow the DUT adequate warm-up time for each luminance level setting before measurements are made, just as when the DUT is first turned on.





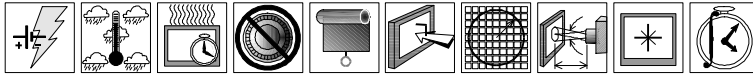
## 302-9 LUMINOUS FLUX

**DESCRIPTION:** We sample the illuminance from the white full screen at a number of angles in the hemisphere in front of the screen in order to obtain an approximate average value for the luminous flux. **Units:** lm.

**Symbol:**  $F$ .

Several methods have been used to measure flux. One involves a large integrating sphere, but the experts tell us that because of the size of the displays and the fact that many displays (such as laptop computers) have large areas of light-absorbing material, the integrating sphere method is either impractical, difficult, or very uncertain. The method we use here involves goniometric illuminance measurements converted to luminous flux.

**SETUP:** White full screen.



**SETUP:** Prepare to measure the illuminance from a white full screen as a function of angle from and around the normal using a goniometer and cosine-corrected illuminance meter. The radius  $r$  of the goniometer hemisphere must be sufficient to include the entire surface of the screen (obviously), and the plane of the screen must lie in the plane defined by the hemisphere, but the exact centering of the screen at the center of the hemisphere is not critical (provided a cosine-corrected illuminance meter is used). The illuminance meter must be fixed at the position of the radius of the hemisphere and must have its normal be directed toward the center of the screen, i.e., always facing the screen.

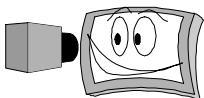
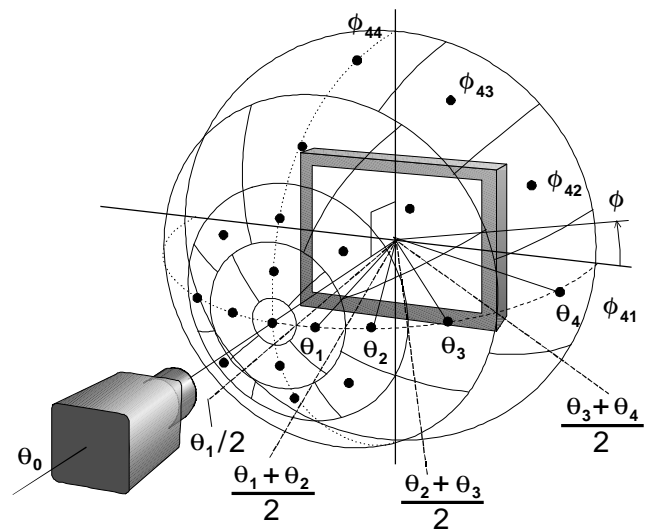
**Note:** The illuminance meter measurement at each position must *not* be corrupted by reflections off of parts of the apparatus including the any bezel, mount, or holder for the screen, the positioning apparatus, etc., or reflections from the walls or other items in the room—even reflections from items behind the display must be controlled.

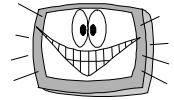
**PROCEDURE:** Define  $n$  inclination angles  $q_i$  from the normal for  $i = 0, 1, 2, \dots, n$ —see the figure. Let the normal be  $q_0 = 0^\circ$  for  $i = 0$ . The  $q_i$  need not be equally spaced between  $0^\circ$  and  $90^\circ$ . For each angle  $q_i$  a number  $N_i$  of measurements will be made at equally-spaced angles  $f_{ij} = j 2\pi/N_i$  for  $j = 0, 1, 2, \dots, N_i - 1$  with respect to the  $x$ -axis (horizontal to the right) in the counterclockwise direction. Here we define at the normal position  $N_0 = 1$  (with only  $j = 0$ ) and  $f_{00} = 0$ . Note that the  $f_{ij}$  are equally spaced angles around the complete circle in this formalism; whereas the  $q_i$  need not be equally spaced. Further, the  $N_i$  need not be the same for each annular ring identified by  $q_i$ . The increment in  $f$  is therefore  $\Delta f = 2\pi/N_i$ . Measure the illuminance  $E_{ij} = E(q_i, f_{ij})$  from the screen at each location  $(q_i, f_{ij})$  using a cosine-corrected illuminance meter. at a single radius  $r$ .

**ANALYSIS:** For each inclination angle  $q_i$  for  $i > 0$  we associate an annular ring on the surface of the hemisphere. At the perpendicular position where  $q_0 = 0$ , we have a spherical cap. The luminous flux (in lumens, lm) will be given by

$$F = r^2 \sum_{i=0}^n \sum_{j=0}^{N_i-1} E_{ij}(q_i, f_{ij}) W_{ij} \quad (1)$$

where  $W_{ij}$  is the solid angle associated with the each equal increment in  $f$  ( $\Delta f = 2\pi/N_i$  with  $\Delta f = 2\pi$  for  $i = 0$  and  $N_i = 1$ ) confined between the angles halfway between the selected (not necessarily equally spaced)  $q_i$ :





$$W_{ij} = \begin{cases} 2\pi \left[ 1 - \cos\left(\frac{q_i}{2}\right) \right], & \text{for } q_0 = 0 \text{ (the cap, } i = 0), \\ \frac{2\pi}{N_i} \left[ \cos\left(\frac{q_{i-1} + q_i}{2}\right) - \cos\left(\frac{q_i + q_{i+1}}{2}\right) \right], & \text{for } 0 < i < n, \text{ for each } j, \\ \frac{2\pi}{N_n} \cos\left(\frac{q_{n-1} + q_n}{2}\right), & \text{for } i = n, \text{ for each } j. \end{cases} \quad (2)$$

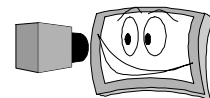
Taking advantage of the fact that all the  $f$  increments are equal allows us to write the luminous flux as

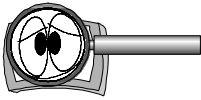
$$F = r^2 \sum_{i=0}^n E_i(q_i) W_i, \text{ where } E_i = \sum_{j=0}^{N_i-1} E_{ij}(q_i, f_{ij}) \quad (3)$$

is the sum of the illuminance contributions around each annulus ( $E_0$  is the luminance at the location of the cap at  $q_0 = 0$ ), and where the solid angle of each annulus  $W_i$  is given by

$$W_i = \begin{cases} 2\pi \left[ 1 - \cos\left(\frac{q_i}{2}\right) \right], & \text{for } q_0 = 0 \text{ (the cap, } i = 0), \\ 2\pi \left[ \cos\left(\frac{q_{i-1} + q_i}{2}\right) - \cos\left(\frac{q_i + q_{i+1}}{2}\right) \right], & \text{for } 0 < i < n, \\ 2\pi \cos\left(\frac{q_{n-1} + q_n}{2}\right), & \text{for } i = n, \end{cases} \quad (4)$$

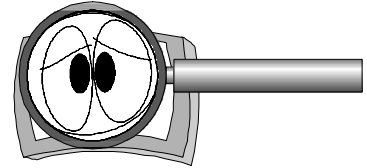
**REPORTING:** Report the luminous flux  $F$  to no more than three significant figures.





## 303 DETAIL, RESOLUTION, AND ARTIFACTS

Measuring the ability of the display to properly render detail often amounts to a measurement of high contrasts of small areas—a most difficult measurement to make. If you are not intimately familiar with some of the techniques for accounting for glare, do see the Metrology section in the appendix under Veiling Glare and Lens Flare Errors (A101-1) for some hints about making better small-area contrast measurements. Here we describe methods to make several measurements of detail contrast.



### 303-1 LINE LUMINANCE AND CONTRAST

### 303-2 $N \times N$ GRILLE LUMINANCE AND CONTRAST

### 303-3 PIXEL FILL FACTOR

### 303-5 INTRACHARACTER LUMINANCE AND CONTRAST

The following procedure describes how a certain type of luminance artifact can be measured.

### 303-4 SHADOWING (LARGE AREA CROSS TALK)

The following is a means of characterizing pixel defects:

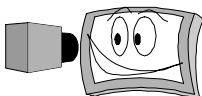
### 303-6 DEFECTIVE PIXEL ANALYSIS

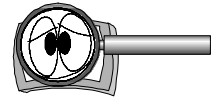
The following discusses a method to determine resolution vs. addressability:

### 303-7 RESOLUTION FROM CONTRAST MODULATION



RUSTIC METROLOGY





**303-1 LINE LUMINANCE AND CONTRAST**

**WARNING**  
**This measurement can be grossly inaccurate unless proper accounting (and/or correction) is made for veiling glare or lens flare (A101-2).**

**DESCRIPTION:** Measure the luminance of a single-pixel vertical (optionally horizontal) black line and the luminance of its white background (positive configuration) attempting to correct for some of the veiling glare in the LMD. Calculate the contrast. **Units:** cd/m<sup>2</sup> if absolute luminance is needed, none for contrast (a ratio). **Symbol:** C<sub>L</sub>.

The display of a black character on a white screen can be one of the most important functions of a display used in a workplace environment. Unfortunately, measuring the luminance or contrast of a black character is difficult and usually very inaccurate. Rather than measuring a character, we recommend a single line in order to provide a more reproducible measurement. See the Comments Section below for more discussion. One contrast metric employed is the ratio of the luminance of the white area L<sub>w</sub> to the luminance of the black line L<sub>b</sub>

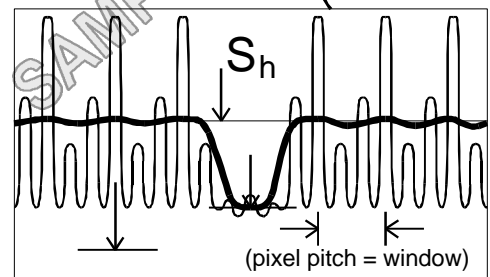
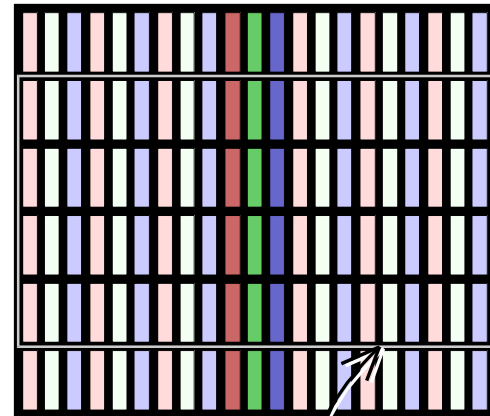
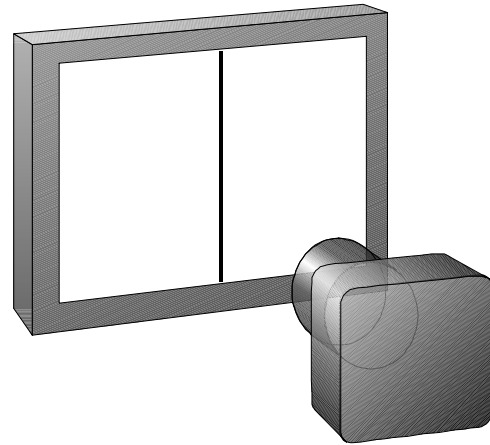
$$C_L = L_w / L_b$$

without glare corruption from, for example, the lens system of the LMD or reflections between the LMD and the FPD. Other metrics that quantify the visibility of the line may also be employed provided they are documented and all interested parties agree to their use.

**Note: (1)** In this measurement a horizontal line can be used, or perhaps a measurement of both vertical and horizontal lines will be desired. The procedure is the same for horizontal lines as for vertical lines; read “horizontal” rather than “vertical” in the following procedure should horizontal lines need to be measured. Additionally, if it is desired to measure the luminance or contrast of a white line on a black screen (negative configuration), the same procedure can be used with “black” and “white” switched around. **(2)** Black and white are described here. Gray levels (or colors) may also be used provided all interested parties are in agreement and all reporting documentation clearly describes any changes.

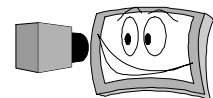
**SETUP:** Generate a single-pixel wide vertical black line near the center of an otherwise white screen on the DUT. Arrange to scan an integral number of horizontal lines (preferably three or more, that is, scan a region equal to an integral number of vertical pixel pitch increments; the figure shows four lines being scanned). The LMD must be photopic and linear but need not be calibrated in cd/m<sup>2</sup> unless a luminance value is required rather than a ratio of luminances. See Section 301 for any standard setup details.

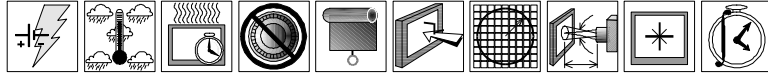
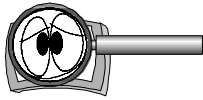
**SPECIFIC:** Equipment: Scanning or array LMD. Test pattern: single vertical line generated near center screen.



↑ S<sub>g</sub> ↑ S<sub>d</sub>  
 — RAW DATA  
 — WINDOW AVERAGE

OPTICAL





**PROCEDURE:** With an array or scanning LMD, obtain the luminance profile of the vertical black-pixel line and the white region. Obtain the net signal  $S$  as a function of distance with any background subtracted (this is the background inherent in the detector if a nonzero signal exists for no light input). A correction for veiling glare  $S_g$  must be made (see A101-1 Veiling Glare and Lens Flare Errors for proper procedures). See the figure for an illustration of the pixel configuration and data.

**ANALYSIS:** Perform a running window average (moving-window-average filter, see A218 for details) of the luminance profile where the averaging window width is as close as possible to the pixel pitch as rendered by the LMD. For an array detector this is however many detector array pixels are needed to cover one display pixel. There should be at least 10 or more detector pixels per display pixel, if possible. For example, if an array detector is used and with the magnification of the imaging lens there are 53 array pixels which cover the DUT pixel pitch, then the running average window width is 53 array pixels wide. From the resulting modulation curve determine (1) the net level of the vertical black line  $S_b = S_d - S_g$ , where  $S_d$  is the minimum (dim) of the vertical black line generated by the DUT, and (2) the net level of the white area on the sides of the black line  $S_w = S_h - S_g$ , where  $S_h$  is the average level (high) of the white area (proportional to the full-screen white luminance perceived by the eye). Compute the small area contrast ratio  $C_L = S_w/S_b$  for the character or stroke contrast ratio. In summary:

$$\begin{aligned}
 S_b &= S_d - S_g \\
 S_w &= S_h - S_g \\
 C_L &= S_w / S_b \\
 C_m &= \frac{S_w - S_b}{S_w + S_b}
 \end{aligned}
 \quad , \text{ where } \left\{ \begin{array}{l} S_g = \text{glare correction} \\ S_h = \text{white level (high)} \\ S_d = \text{black level (dim)} \\ S_w = \text{net white value} \\ S_b = \text{net black value} \\ C_L = \text{line contrast} \\ C_m = \text{Michelson contrast} \end{array} \right.$$

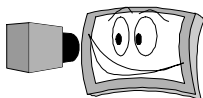
Analysis (Sample Data)	
Glare: $S_g$	1772
High: $S_h$	9331
Dim: $S_d$	4239
$S_w = S_h - S_g$	7559
$S_b = S_d - S_g$	2467
$C_L = S_w/S_b$	3.1

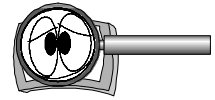
Reporting (Sample Data)	
$S_g$	1772
$S_w$	7559
$S_b$	2467
$C_L$	3.1

**REPORTING:** Report the line contrast ratio to no more than three significant figures. It also may be useful to report the values of the glare correction, net white, and net black signals.

**COMMENTS:** The method outlined above provides an approximation to the contrast of a line and may be an approximation to the stroke contrast of a character. Character contrasts are difficult to measure accurately because the contributions of glare can be different for each part of the letter. This nonuniformity is not necessarily because the letter changes its blackness, but because the recording lens system produces different amounts of glare depending upon the size and shape of the black area measured. For more details on obtaining an approximate veiling-glare correction see the Metrology Appendix: Veiling Glare and Lens Flare Errors (Accounting for Glare in Small-Area Measurements—A101-2).

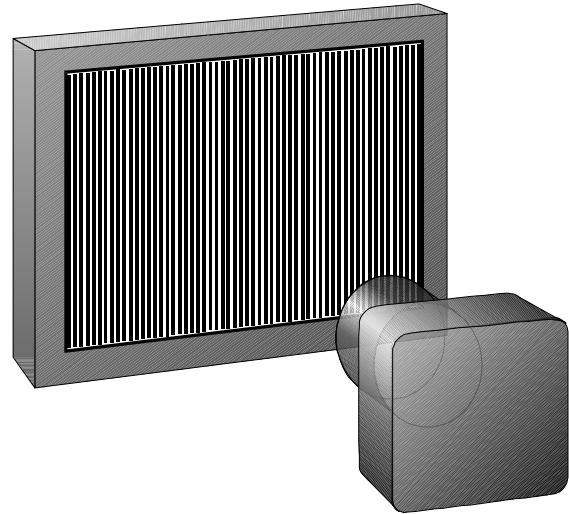
This measurement is understandably easier when a white line on a black screen is measured—the negative configuration. (Under such conditions even character stroke contrasts can be attempted with greater ease.) For the negative configuration (white line on black), the correction arising from glare will be much smaller than with a black line on a white screen, and may possibly be negligible. The window average is performed and the peak of the window average is used for  $S_h$  (an average cannot be obtained because there is only one white line). However, an average can be obtained for the dark measurement  $S_d$ .





**303-2 N × N GRILLE LUMINANCE AND CONTRAST**

**WARNING**  
 This measurement can be grossly inaccurate unless proper accounting (and/or correction) is made for veiling glare or lens flare (A101-2).



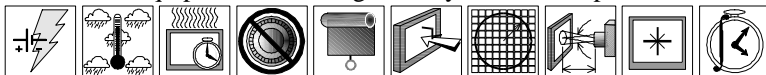
**DESCRIPTION:** Measure the small area luminances at the center of the screen of horizontal and vertical grille test patterns consisting of alternating white and black horizontal or vertical lines covering the entire screen. Calculate the contrast ratio obtained (or other suitable contrast metric). **Units:** cd/m<sup>2</sup> if absolute luminance is needed, none for contrast (a ratio). **Symbol:** C<sub>G</sub> (optionally C<sub>m</sub>)

The difficulty is to accurately determine the luminance of the black line L<sub>b</sub> between white lines L<sub>w</sub> of the same width without corruption from, for example, the lens system of the LMD or reflections between the LMD and the FPD. We call for the contrast ratio C<sub>G</sub> = L<sub>w</sub>/L<sub>b</sub>, here, but other contrast metrics may be used provided they are documented and all interested parties agree to their use. [Optionally, the Michelson contrast is C<sub>m</sub> = (L<sub>w</sub> - L<sub>b</sub>)/(L<sub>w</sub> + L<sub>b</sub>).] An n × n grille is either horizontal or vertical alternating white and black lines each having a width of n pixels. It is important in such measurements to attempt to account for any contrast-reducing glare (veiling glare) in the measurement system. One use of C<sub>m</sub> is found in 303-7 in determining the actual resolution of a display.

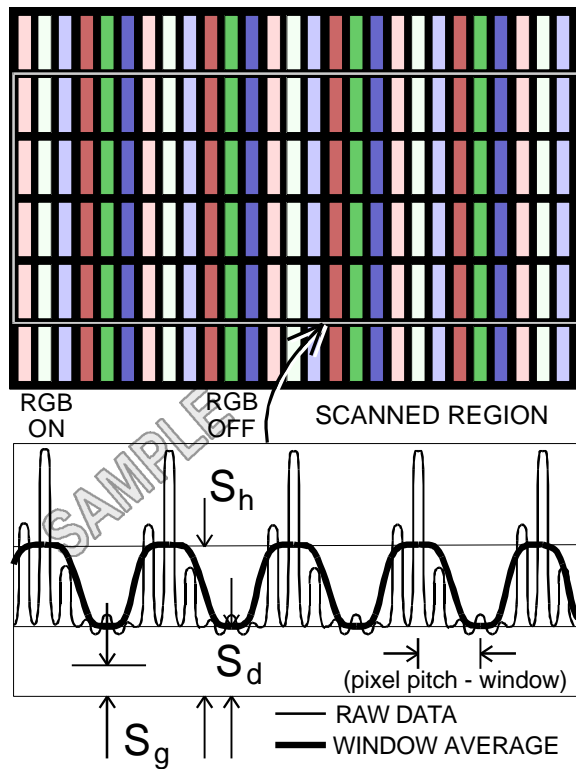
**Note:** Black and white are described here. Gray levels (or colors) may also be used provided all interested parties are in agreement and all reporting documentation clearly describes any changes.

**SETUP:** Alternatively display a horizontal grille and then a vertical grille test pattern and arrange for a spatially resolving LMD to measure the luminance profiles at screen center. Start with 1 × 1 grilles. Some display technologies will display a noticeable flicker when displaying a 1 × 1 horizontal grille; should that be the case, then use a 2 × 2 horizontal grille instead. A correction must be made for veiling glare (see Veiling Glare and Lens Flare Errors section A101-1). Arrange to measure an integral number of rows (or columns). See Section 301 for standard setup details.

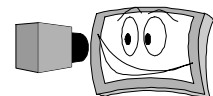
**SPECIFIC:** Equipment: Scanning or array LMD. Test pattern: horizontal grille, vertical grille.

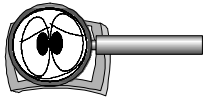


**PROCEDURE:** With an array or scanning LMD, measure luminance profiles for both horizontal and vertical grille patterns subject to above setup conditions. Obtain the net signal S as a function of distance with any



OPTICAL





background subtracted (this is the background inherent in the detector if a nonzero signal exists for no light input). A correction for veiling glare  $S_g$  must be made (see A101-1 Veiling Glare and Lens Flare Errors for proper procedures). See the figure for an illustration of the pixel configuration and data.

**ANALYSIS:** Perform a running average (moving-window-average filter, see A218 for details) of each luminance profile where the averaging window width is as close as possible to the pixel pitch as rendered by the LMD. For an array detector this is however many detector array pixels are needed to cover one display pixel. There should be at least 10 or more detector pixels per display pixel, if possible. For example, if an array detector is used and with the magnification of the imaging lens there are 53 array pixels which cover the DUT pixel pitch, then the running average window width is 53 array pixels wide. From the resulting modulation curve determine (1) the net level of the grille black lines  $S_b = S_d - S_g$ , where  $S_d$  is the minimum of the grille black lines, and (2) the net level of the grille white lines between the specified black lines  $S_w = S_h - S_g$ , where  $S_h$  is the average maximum of the grille white lines. Compute the grille contrast ratio  $C_G = S_w/S_b$  for horizontal and for vertical grille patterns. In summary:

$$\begin{aligned}
 S_w &= S_h - S_g \\
 S_b &= S_d - S_g \\
 C_G &= S_w/S_b, \text{ where } \\
 C_m &= \frac{S_w - S_b}{S_w + S_b}
 \end{aligned}
 \left\{ \begin{array}{l}
 S_g = \text{glare correction} \\
 S_h = \text{white line average (high)} \\
 S_d = \text{black line average (dim)} \\
 S_w = \text{net white value} \\
 S_b = \text{net black value} \\
 C_G = \text{grille contrast} \\
 C_m = \text{Michelson contrast or contrast modulation}
 \end{array} \right.$$

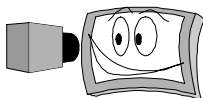
Analysis (Sample Data)	
Orientation	er.
Grille	1 x 1
Glare: $S_g$	1772
High: $S_h$	7559
Dim: $S_d$	2467
$S_w = S_h - S_g$	5787
$S_b = S_d - S_g$	695
$C_G = S_w/S_b$	8.3
$C_m$	0.786
Orientation	or.
Grille	2 x 2
Glare: $S_g$	1342
High: $S_h$	7623
Dim: $S_d$	1983
$S_w$	6281
$S_b$	641
$C_G$	9.8
$C_m$	0.814

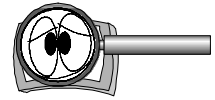
The sample data shown here are net CCD counts from a photopic camera. The CCD counts  $S$  are only proportional to the luminance values.

**REPORTING:** Report the grille contrast ratio  $C_G$  as a number to no more than three significant figures. Also report the type of grille pattern used. It is suggested that the mask, net white, and net black signals be presented as well. The luminance of the white and black lines may be reported if the device is properly calibrated for absolute luminance measurements.

**COMMENTS:** Grille contrast ratio measurements are required for the determination of true resolution because spatial resolution capabilities of the DUT may or may not be closely correlated with the addressability. The contrast ratio of a display is very sensitive to an accurate black measurement, and hence any veiling glare measurement, see Uncertainty Evaluations (A108) in the Metrology Appendix. There may be complications associated with making small area contrast measurements, see Veiling Glare and Lens Flare Errors (A101).

Reporting Results - Sample Data		
Grille Contrasts	Horizontal Grille	Vertical Grille
Grille type:	2 x 2	2 x 2
$C_G$	3.1	2.3
$L_w$	13.8 cd/m <sup>2</sup>	9.82 cd/m <sup>2</sup>
$L_b$	4.45 cd/m <sup>2</sup>	4.41 cd/m <sup>2</sup>
$L_{ave}$	9.13 cd/m <sup>2</sup>	7.12 cd/m <sup>2</sup>





### 303-3 PIXEL FILL FACTOR

**DESCRIPTION:** We measure the pixel fill factor using an area LMD or calculate it based on design parameters.

The pixel fill factor is the amount of the area producing useful luminance compared to the amount of the area allocated to the pixel. Fill factors that are not 100 % can influence display quality from an ergonomic standpoint.

Note that some displays have well-defined pixels because of a known black matrix. In such cases the pixel fill factor may be calculated from geometry.

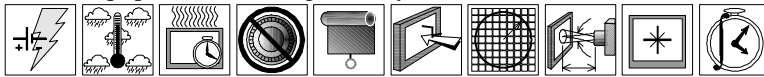
In the example at the right, what might be a typical TFT LCD subpixel arrangement, a  $60H \times 50V$  array detector measures a single pixel. The pixel size is  $46 \times 46$  or 2116 detector pixels, the red, green, and blue subpixels are each covered by 420 detector pixels. The fill factor is

$$f = \frac{420 + 420 + 420}{2116} = 0.595 \text{ or } 60\% .$$

In what follows we refer to subpixels for the case of color displays. Should a monochrome display be measured, read “pixel” instead of “subpixel.”

**SETUP:** If the subpixels are relatively uniform ( $\pm 20\%$  of average luminance) and well-defined (sharp edges visible where the average luminance of the subpixel is attained from the black surround within a distance of 10 % of the smallest horizontal width or height of the subpixel), then it is possible to calculate the fill factor if the pixel design parameters are known or can readily be measured. If the pixels are not uniform in luminance cross-section, arrange for either a scanning or array LMD to measure the area luminance of the subpixels over the entire area of at least one typical pixel.

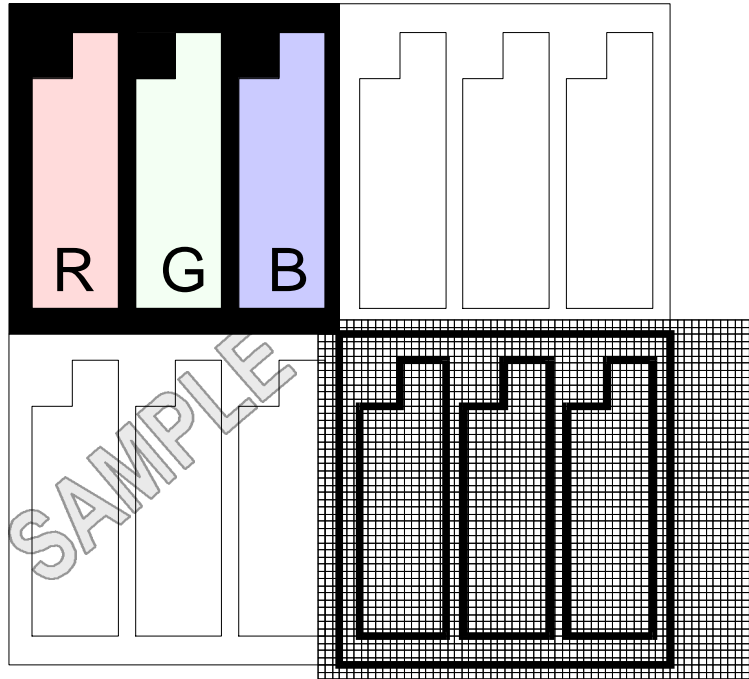
**SPECIFIC:** Equipment: Scanning or array LMD. White full screen.



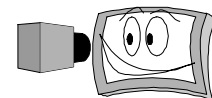
#### PROCEDURE & ANALYSIS:

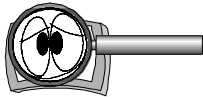
**Well-Defined Subpixels:** For many display technologies the subpixel matrix mask and resulting pixels are well-defined and relatively uniform (say  $\pm 20\%$  of the average luminance). In such a case, the fill factor can be calculated from geometry if the design spatial parameters are known, or it may be calculated by measuring the sizes of the subpixels: Sum up the area of the subpixels  $s = s_{\text{red}} + s_{\text{gm}} + s_{\text{blu}}$  and divide by the area allocated to the pixel  $a = P_H P_V$ , where  $s_i$  is the area of each subpixel,  $P_H$  is the pixel pitch in the horizontal direction, and  $P_V$  is the pixel pitch in the vertical direction. The fill factor is  $f = s/a$ .

**Non-Uniform Subpixels:** With other technologies where the subpixel is not uniform in its cross-section as viewed, a spatially resolved LMD must be used to measure the luminance distribution of each subpixel. The LMD need not be calibrated in units of luminance, but it should be linear over the range of luminances measured. Using a white screen, select one pixel near the center of the screen that appears to be typical ( $\pm 10\%$  of average in the center region). For each subpixel  $i$  within that pixel determine the peak subpixel level  $S_i$ . Locate the darkest detector pixel in the near vicinity of the selected pixel (such as within the black matrix mask that separates the subpixels or within some other available structure that is black) then determine the



*Fig. 1. A  $60H \times 50V$  array detector measuring a single pixel.*





minimum of the black area (its dimness)  $S_d$ . This dimness value includes the true black value  $S_b$  and any additional glare  $S_g$  so that  $S_d = S_b + S_g$ . We will call the measured luminance of any detector pixel within the subpixel  $S_i(x,y)$ , where  $(x,y)$  denotes the location of the detector pixel. The net luminance of each detector pixel within any subpixel is then the measured luminance with the true black value and the glare subtracted  $K_i(x,y) = S_i(x,y) - S_g - S_b = S_i(x,y) - S_d$ . The net maximum luminance is given by  $S_i - S_g - S_b$ . Now, determine the area  $s_i$  (in number of detector pixels) of each subpixel for which the net luminance of that subpixel  $K_i(x,y)$  is not less than a certain threshold fraction  $t$  of the net maximum luminance:  $K_i(x,y) \geq t (S_i - S_g - S_b)$  or  $K_i(x,y) \geq t (S_i - S_d)$ . We can rewrite this in terms of the measured quantities  $S_i(x,y) \geq S_d + t (S_i - S_d) = \tau S_i + (1 - \tau)S_d$ , which we probably could have written down directly. The threshold fraction  $t$  used should be reported. We recommend either 5 % ( $t = 0.05$ ) or 10 % ( $t = 0.1$ ). The fill factor is then defined as  $f = s/a$ , where  $s = \sum s_i$  is the area (in detector pixels) of all subpixels brighter than the threshold relative to each subpixel, and  $a = P_H P_V$  is the area allocated to the entire pixel. Some documents use a 50 % threshold. However, the eye perceives the size closer to the 5 % or 10 % threshold. Note that the veiling glare does not ultimately have to be measured explicitly since it is implicitly contained within  $S_d$ .

It is recommended that the magnification of the optical system be sufficiently high such that the smallest horizontal or vertical dimension of each subpixel can be resolved and quantized by at least 10 detector pixels (preferably more) assuming an array detector is used. Use a calibrated ruler such as a graticule scale for a measuring loupe or a microscope calibration ruler in order to determine the size associated with each array detection pixel should their areas need to be measured. Then simply count the number of array detection pixels that have a luminance greater than or equal to the threshold  $S_d + t (S_i - S_d)$  for each display subpixel within a pixel.

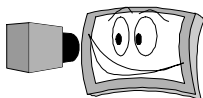
Keep in mind that if an optical system is used such as a microscope or a system where the lens of the LMD subtends a significant angle (large  $q_L$ ), the uncertainty in the measurement increases. The lens subtense limit specified in this document is  $2^\circ$  and is difficult to maintain in producing high-magnification images unless a long-distance microscope is used. Tests may have to be done to assure that too wide a lens subtense angle will not perturb the measurements; see A103 under Diagnostic—Verification of Subtense Angle Suitability of the LMD. Most will be faced with using a lens system that exceeds the  $2^\circ$  limit. If that is the case, a note of the optical arrangement should be made in the reporting document. In all cases report the fill factor and the threshold fraction employed.

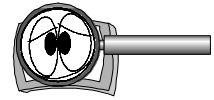
**REPORTING:** Report the threshold (if used), the area of the display pixel, the area of the display subpixels above the threshold (if used), and the fill factor. Report the fill factor to no more than three significant figures. When reporting in percent, round off to the nearest integer percent.

**COMMENTS:** None.

Reporting Sample Data	
Threshold	10
Pixel Area	6724 px
Filled Area	3792 px
Fill Factor	0.564
	in percent 56

Analysis of Sample Data (Using an Array Detector)			
Threshold $t$		10	Luminance of black area, $S_d$ (counts)
		82 x 82	7296
Pixel coverage by detector pixels			Pixel area $a$ in detector pixels (detector pixels)
			6724
Subpixel	Maximum Luminance $S_i$ , (in counts)	Threshold Level $tS_i + (1 - t)S_d$ , (in counts)	Area Above Threshold (in detector pixels)
Red	21757	8742	1239
Green	27268	9293	1381
Blue	20774	8644	1172
Total area above threshold in detector pixels			3792
Fill factor			0.564





### 303-4 SHADOWING (GRAY-SCALE ARTIFACTS)

(cross talk, large area cross talk, cross coupling, streaking, trailing)



**DESCRIPTION:** Measure the worst-case shadowing in eight-levels of gray.

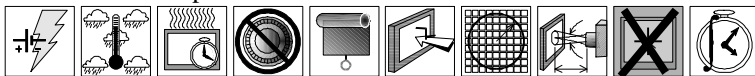
**Units:** Percent perturbation of the luminance of the gray level. **Symbol:** None.

Shadowing refers to how one part of the screen can affect another part of the screen usually along rows or columns. Since the eye is a good edge detector, the slightest amount of shadowing usually is objectionable and may be found to be difficult to measure accurately. Shadowing is illustrated in Fig. 1 in the third screen from the top. What we measure here is worst case luminance shadowing of eight levels of gray. There can be similar effects with colors where the luminance may or may not be affected significantly. A color shift metric such as  $\Delta u'v'$  or  $\Delta E$  could be used (see A201).

**SETUP:** Note that all the patterns referred to in the setup below can be found in the files FPDMALL.???. However, the levels of the gray boxes in the five positions and the background must be changed appropriately for the worst-case shadowing (to cover all possibilities would require 560 frames).

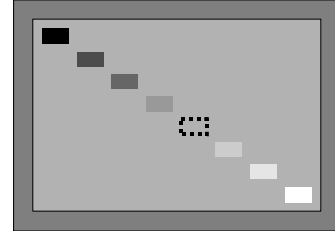
**Establishment of Worst-Case Shadowing:** Using a series of diagonal boxes of eight gray levels, change the background gray level over all eight gray levels (other patterns are acceptable so long as all combination of the eight gray levels are examined for shadowing). Look for the worst-case of shadowing. It may be necessary to quickly measure the shadowing: If  $L_s$  is the perturbed luminance of the background and  $L_{bkg}$  is the background luminance without perturbation, then the shadowing measure is  $|L_s - L_{bkg}|/L_{bkg}$ . Once the worst case shadowing gray levels have been determined,  $G_{bkg}$  and  $G_s$ , proceed to the next part of setup.

**Patterns for Shadowing Testing:** There are a total of ten patterns used in this measurement: five single box patterns and five full-screen gray-level patterns interleaved. The sequence of five box patterns has a box sequentially placed (A) above, (B) to the left of, (D) to the right of, (E) below, and (C) at the center of the screen, one box for each pattern (this is the reading order in several languages: left-to-right, top-to-bottom). The edge boxes are centered along the closest side. The box sides are approximately 1/5 to 1/6 the width and height of the screen, and the box is separated from the edge of the screen by approximately half its width or height—see Fig. 1. Placement of the boxes should be  $\pm 5\%$  of the linear dimensions of the screen. The gray level of the boxes is  $G_s$  and the background gray level is  $G_{bkg}$ . Each one-box pattern is separated in the sequence by a blank full screen of gray level  $G_{bkg}$ . See Section 301 for any standard setup details.

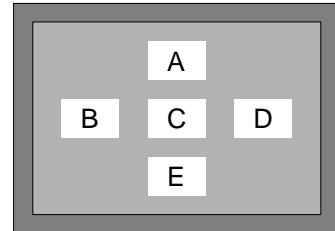


**PROCEDURE:** After having selected the worst-case shadowing during the initial setup, start with an edge box, for example, at the B position. Measure the luminance at center and at the position opposite to the box (position D). Go to the next pattern without the box and measure at positions C and at the center. Repeat this procedure for the other edge boxes (at A, D, and E). When the box is at the center position C measure at each of the other box positions A, B, D, and E (not at center, obviously). The exact position of the area at which the measurement is made does not need to be precise, within  $\pm 5\%$  of the linear dimensions of the screen will do. Determine the worst case shadowing configuration (worst case being the greatest change in luminance with and without the box present). Select the worst case shadowing box position from all the measurements made

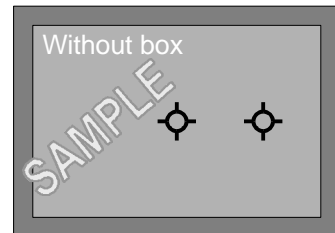
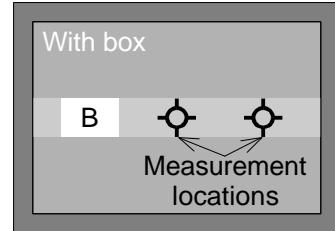
Testing pattern sample:



Measuring areas:

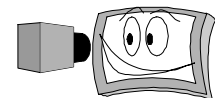


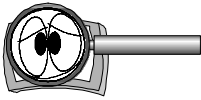
Measurement example:



**Fig. 1.** Testing pattern, sample box positions, and measurement example with box at C position.

OPTICAL





and secure the LMD in the position to repeat the measurement of the worst case configuration. With the LMD in a secure position so it will not move relative to the screen, measure the luminance with the box present  $L_s$  and without the box present  $L_{bkg}$ . Critical alignment of the LMD is not necessary, but when the final measurement is made it is important that the LMD not move relative to the screen.

**ANALYSIS:** The shadowing is expressed in percent:  $S = 100\% |L_s - L_{bkg}| / L_{bkg}$ .

**REPORTING:** Report (1) the maximum shadowing in percent, where the measurement was made, (2) the background gray level in percent of white (white being 100 % and black,  $x$  %, whatever fraction black is of white) and/or level (7=white, 0=black), (3) the box gray level (report in same format as the background), and (4) the position of the box used (A-D) to produce the shadowing. In the report sample below, B refers to luminance taken with the box present, and N refers to the luminance taken with no box present.

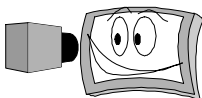
**COMMENTS:** Depending upon technology, there could be some dependencies on gray scale (addressed in this procedure) and color (not directly addressed herein). Sixteen gray levels can optionally be used if desired. The worst case is generally display dependent, in which case both the luminance level of the offending box and the background should be determined. Be careful of changing positions when taking the final luminance measurements because of the nonuniformities that may be inherent in the screen. If a stable mount cannot be provided, as when using a hand-held meter, consider using an alignment mask.

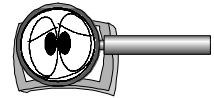
The expression for the shadowing  $S = 100\% |L_s - L_{bkg}| / L_{bkg}$  becomes infinite for zero luminance backgrounds ( $L_{bkg} = 0$ ). We assume that you will generally not be dealing with such a display, usually there is some light in the black state (see 301-3a). Your instrumentation may not be able to measure it accurately, however. In such a case you might use the lowest luminance level that your meter can measure (we are assuming good instrumentation). For example, suppose we measure  $L_s = 1 \text{ cd/m}^2$  and  $L_{bkg} = 0.1 \text{ cd/m}^2$ . Then  $S = 900\%$ . That may seem to be high, but not really. If you are dealing with a display that works at these levels, then you should have instrumentation that can accurately measure it. Further, if you are expecting  $0.1 \text{ cd/m}^2$  and you get  $1 \text{ cd/m}^2$ , you are bound to be very disappointed, and perhaps 900 % is not such an inappropriate evaluation after all. (Some consider the useful display black limit to be  $0.01 \text{ cd/m}^2$ , so these are not unreasonable levels for certain tasks.)

Adaptation of the method to include colors is straightforward. After determining the two-color combination that produces the most offensive shadowing, follow the same procedure as above, but also measure the chromaticity coordinates ( $x, y$ ). Instead of calculating a percent fractional change in luminance, compute a color change metric such as  $\Delta U'V'$  for only color changes or  $\Delta E$  to include the effects of luminance changes as well (see A201).

Different patterns may be employed as long as all interested parties agree to the modifications. For example, the boxes specified in this procedure may be too small to indicate shadowing that may be revealed by boxes that are larger than half of the screen height or width—or other shapes. For such extended boxes, it would no longer be possible to measure at the center of the screen. Again, any changes should be clearly documented.

Reporting - Sample Data			
Shadowing=100% B-N N` (303-4)			
Box at (A-D)	6	L (cd/m <sup>2</sup> )	
Box (0-7)	0	B=box	95
Bkg. (0-7)	7	N=no box	103
Shadowing %	7.8		

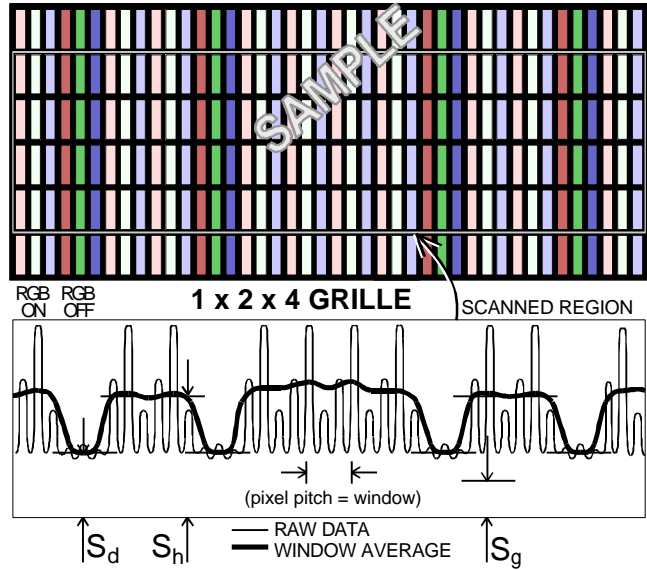




### 303-5 INTRACHARACTER LUMINANCE AND CONTRAST

( $m \times n \times q \dots$  grille contrast ratio)

**WARNING**  
 This measurement can be grossly inaccurate unless proper accounting (and/or correction) is made for veiling glare or lens flare (A101-2).



**DESCRIPTION:** Measure the small area luminances at the center of the screen of horizontal and vertical grille test patterns consisting of alternating white and black horizontal or vertical lines of various widths covering the entire screen. Calculate the contrast ratio obtained (or other suitable contrast metric). **Units:**  $\text{cd}/\text{m}^2$  if absolute luminance is needed, none for contrast (a ratio).

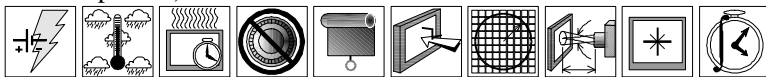
**Symbol:**  $C_G$  (optionally  $C_m$ )

This is an extension of the  $n \times n$  grille contrast ratio (303-2). An  $m \times n \times m \times q$  grille is either horizontal or vertical alternating white and black lines in a repeating pattern of two black lines of  $m$ -pixels width separated by one white line of  $n$ -pixels in width and by one white line  $q$ -pixels in width. The region of interest is usually the regions where the lines are closest together and not the white area separating the groups (the  $q$ -pixel lines in the above example). For only three lines specified we will use the following convention, an  $m \times n \times q$  grille is a pair of black lines of  $m$ -pixels in width separated by a white line of  $n$  pixels in width then separated by a black line  $q$ -pixels in width. Thus, a  $2 \times 1 \times 5$  grille is a repeating pattern of two black lines, one white line, two black lines, and then five lines white, and so forth. Alternatively, we could specify the same line pattern by a  $2 \times 1 \times 2 \times 5$  grille, where we are explicitly describing each line in the repeating pattern. The multiple-line grille can be obviously extended to simulate different patterns by adding lines such as an  $m \times n \times m \times n \times m \times q$  grille, which would be three  $m$ -pixel width lines separated by two  $n$ -pixel width lines and one  $q$ -pixel width line. If the  $q$  factor is omitted in the three-line specification it is understood that the  $m \times n$  pattern repeats continuously. It is important in such measurements to attempt to account for any contrast-reducing glare (veiling glare) in the measurement system. The reason for this measurement is to provide a more rigorous method to approximate character contrasts. The figure shows a  $1 \times 2 \times 4$  grille, which could also be expressed as a  $1 \times 2 \times 1 \times 4$  grille if each line thickness is specified. Obviously, it is clearer to represent each line by its number of pixels in the repeating pattern.

**Note:** Black and white are described here. Gray levels (or colors) may also be used provided all interested parties are in agreement and all reporting documentation clearly describes any changes.

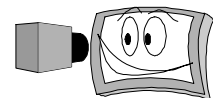
**SETUP:** Alternatively display a horizontal grille (if required) and then a vertical grille test pattern and arrange for a spatially resolving LMD to measure the luminance profiles at screen center. A correction must be made for veiling glare (see Veiling Glare and Lens Flare Errors section A101-1). Arrange to measure an integral number of rows (or columns). The grille that is required depends upon the people involved and the application. It must be negotiated by all interested parties. See Section 301 for standard setup details.

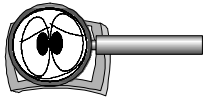
**SPECIFIC:** Equipment: Scanning or array LMD. Test pattern: horizontal grille, vertical grille (repeating on/off line pattern).



**PROCEDURE:** With an array or scanning LMD, measure luminance profiles for both horizontal and vertical grille patterns subject to above setup conditions. Obtain the net signal  $S$  as a function of distance with any

OPTICAL





background subtracted (this is the background inherent in the detector if a nonzero signal exists for no light input). A correction for veiling glare  $S_g$  must be made (see A101-1 Veiling Glare and Lens Flare Errors for proper procedures). See the figure for an illustration of the pixel configuration and data.

**ANALYSIS:** Perform a running window average (moving-window-average filter, see A218 for details) of the luminance profile where the averaging window width is as close as possible to the pixel pitch as rendered by the LMD. For an array detector this is however many detector array pixels are needed to cover one display pixel. There should be at least 10 or more detector pixels per display pixel, if possible. For example, if an array detector is used and with the magnification of the imaging lens there are 53 array pixels which cover the DUT pixel pitch, then the running average window width is 53 array pixels wide. From the resulting modulation curve determine (1) the net level of the grille black line  $S_b = S_d - S_g$ , where  $S_d$  is the minimum of the grille black lines, and (2) the net level of the grille white line  $S_w = S_h - S_g$ , where  $S_h$  is the average maximum of the grille white lines. Compute the small area contrast ratio  $C_G = S_w/S_b$  for horizontal and for vertical grille patterns. In summary:

$$\begin{aligned}
 S_w &= S_h - S_g \\
 S_b &= S_d - S_g \\
 C_G &= S_w/S_b \\
 C_m &= \frac{S_w - S_b}{S_w + S_b}
 \end{aligned}
 \quad , \text{ where }
 \begin{cases}
 S_g = \text{glare correction} \\
 S_h = \text{white line average (high)} \\
 S_d = \text{black line average (dim)} \\
 S_w = \text{net white value} \\
 S_b = \text{net black value} \\
 C_G = \text{grille contrast} \\
 C_m = \text{Michelson contrast or contrast modulation}
 \end{cases}$$

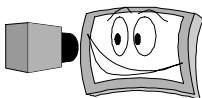
Analysis (Sample Data)	
Orientation	er.
Grille	1 x 2 x 4
Mask: $S_g$	1772
White: $S_h$	7559
Black: $S_d$	2467
$S_w$	5787
$S_b$	695
$C_G$	3.8
Orientation	or.
Grille	2 x 3 x 5
Mask: $S_g$	1653
White: $S_h$	7489
Black: $S_d$	2217
$S_w$	5836
$S_b$	564
$C_G$	10.3

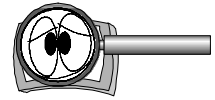
**REPORTING:** Report the grille contrast ratio  $C_G$  as a number to no more than three significant figures. Also report the type of grille pattern used. It is suggested that the mask, net white, and net black signals be presented as well. If luminance levels are required then the camera must be calibrated in  $cd/m^2$  for absolute measurements.

Reporting Results - Sample Data		
Grille Contrasts	Horizontal Grille	Vertical Grille
Grille type:	2x 3 x 5	1 x 2 x 4
$C_G$	10.3	3.8

**COMMENTS:** The contrast ratio of a display is very sensitive to an accurate black measurement, see Uncertainty Evaluations (A108) in the Metrology Appendix. There may be complications associated with making small area contrast measurements, see Veiling Glare and Lens Flare Errors (A101).

The purpose of the  $m \times n \times q...$  grille measurement is to approximate the contrast found with a character. When measuring the character contrast, the height of the character can influence the value of the black measured because of glare (at the very least). If glare is going to be measured by using a replica mask, making a mask the same size and shape of the character would be very difficult. It is much easier to produce an opaque black replica mask of a line than a character. The black measured on a character can change depending upon where the black is measured, the measurement of lines provides a more reproducible measurement. The reason for the  $m \times n \times q...$  grille is to simulate a character like a small “m” where the distance between the legs of the “m” might be two pixels and the leg width might be one pixel, but there may be three or more pixels separating the characters. Thus a  $1 \times 2 \times 1 \times 2 \times 1 \times 3$  grille might adequately simulate the “m” for this example.





## 303-6 DEFECTIVE PIXEL ANALYSIS

There are three parts of this analysis: (a) How we specify, categorize, and measure a defective pixel; (b) how we specify, categorize, and measure the clustering density; and (c) how we specify a minimum defective pixel separation (if such a specification is necessary). Since the clustering density—the number of defects per unit area or number of pixels—is a quantity that gets smaller as the quality of the screen improves, we define a metric that increases as the screen improves. The “clustering quality” or “defect dispersion quality” is defined as the number of good pixels per number of bad pixels. This clustering quality is large, generally several thousand, and increases with fewer defects. The clustering quality metric is also independent of screen size since it is based on the relative number of pixels rather than the area. All interested parties must mutually agree which specifications are employed to derive the defective pixel analysis.

### 303-6a Defective Pixel Characterization and Measurement

**DESCRIPTION:** We discuss a method to characterize pixel defects.

Defective Pixels are pixels that operate improperly when addressed with video information. For example, a pixel addressed to turn black may remain white. If it never changes state, it is said to be a **stuck** pixel. If it changes state without the proper addressing signal, it may be **intermittent**. Detailed classification of defective pixel types follows below.

For another method of classification of pixel defects that characterizes a display, ISO 13406-2 [2] may be used at the user's discretion. The ISO classification defines the class of the display based upon the number of defects. We clarify pixel defect types further.

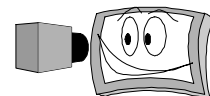
Note that defective column and rows are not truly pixel defects (e.g., driver-related problems, address-line problems, etc.), but may have the same characteristics as defined by defect types 1–5 in this section. It is up the user to determine if any row and pixel defects are acceptable. They would be reported as **defective rows** or **defective columns**. Often people find that column and row defects are unacceptable.

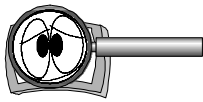
**Thresholds of observability:** In what follows we discuss pixels that are stuck on and stuck off by saying their luminance is either always above a white threshold or below a black threshold. There are two types of thresholds: luminance thresholds and lightness thresholds. Historically, the white threshold was 75 % of the full-white-screen luminance, and the black threshold was 25 %. The problem with this is that the luminance scale is a linear scale and does not relate well to what the eye sees as the white or black quality of the pixel. Thus, a 25 %-luminance-of-white added to black appears to the eye as a 57 % relative lightness. A much darker pixel than this would be quite visible against a dark background and could be objectionable. Also, the 75 %-luminance-of-white pixel appears to the eye as 89 % of white, and it may even be hard to identify well in a sea of white pixels. To describe the dark and light thresholds as what the eye would see we need to use a lightness scale, and  $L^*$  is the best candidate at the present time—see A209, Nonlinear Response of the Eye, and A201 Photometry and Colorimetry Summary. If we specify lightness thresholds as what the eye would perceive to be 25 % and 75 % lightness between black and white, we would need the luminance threshold of black at 4.415 % and of white at 48.28 % of the white luminance. What is important is what the eye sees, so we would suggest that the lightness thresholds be adopted. However, the luminance thresholds have such an ingrained history, we felt that we had to include them here. Whichever threshold criterion is chosen (or any other criterion used), it should be negotiated by the interested parties and should be reported clearly.

<b>Thresholds of Observability</b>			
Threshold Criterion	Required Luminance Thresholds, $L_{WT}$ , $L_{BT}$	Lightness Perceived by Eye, $L^*/L^*_w$	Partial Pixel Areas† $S_{UT}$ , $S_{LT}$
25 % Luminance ( $L$ )	25 %: $L_{BT} = 0.25L_w$	57.1 %	25 %: $S_{LT} = 0.25S_p$
75 % Luminance ( $L$ )	75 %: $L_{WT} = 0.75L_w$	89.4 %	75 %: $S_{UT} = 0.75S_p$
25 % Lightness ( $L^*$ )	4.415 %: $L_{BT} = 0.04415L_w$	25 %	4.415 %: $S_{LT} = 0.04415S_p$
75 % Lightness ( $L^*$ )	48.28 %: $L_{WT} = 0.4828L_w$	75 %	48.28 %: $S_{UT} = 0.4828S_p$

†  $S_p$  is the total area of the light-producing part of the pixel, e.g., the total subpixel area.

OPTICAL





**SETUP:** The visibility of pixel defects depends on both the type of defects and the video being displayed. For example, pixels that are stuck white will not be visible on an all white display but will be obvious on a black screen. Therefore the user must change the video content as appropriate to observe the defective pixels.

**PROCEDURE:** Defective pixels are usually assessed visually, as it is very difficult to properly measure them. A thorough analysis would be to measure each pixel and account for glare contributions to any dark pixel encountered. *Even if the defective pixels are identified by the eye and then measured to see if they fall within or without a threshold, veiling glare must be considered to obtain even an approximate measurement of a dark pixel in the presence of a white background—see A101, Veiling Glare and Lens Flare Errors.* Conditions for viewing pixel defects are subject to supplier/customer agreements. Guidelines may be considered as follows: Dark room conditions are recommended for the best viewing of pixel defects. The observer may look at any distance or angle to both observe the defects and assess them and may use a magnifying device to better categorize them by type. Again, any video pattern may be used to help observe defects. In the following material, *S* is a measure of areas associated with the pixel.

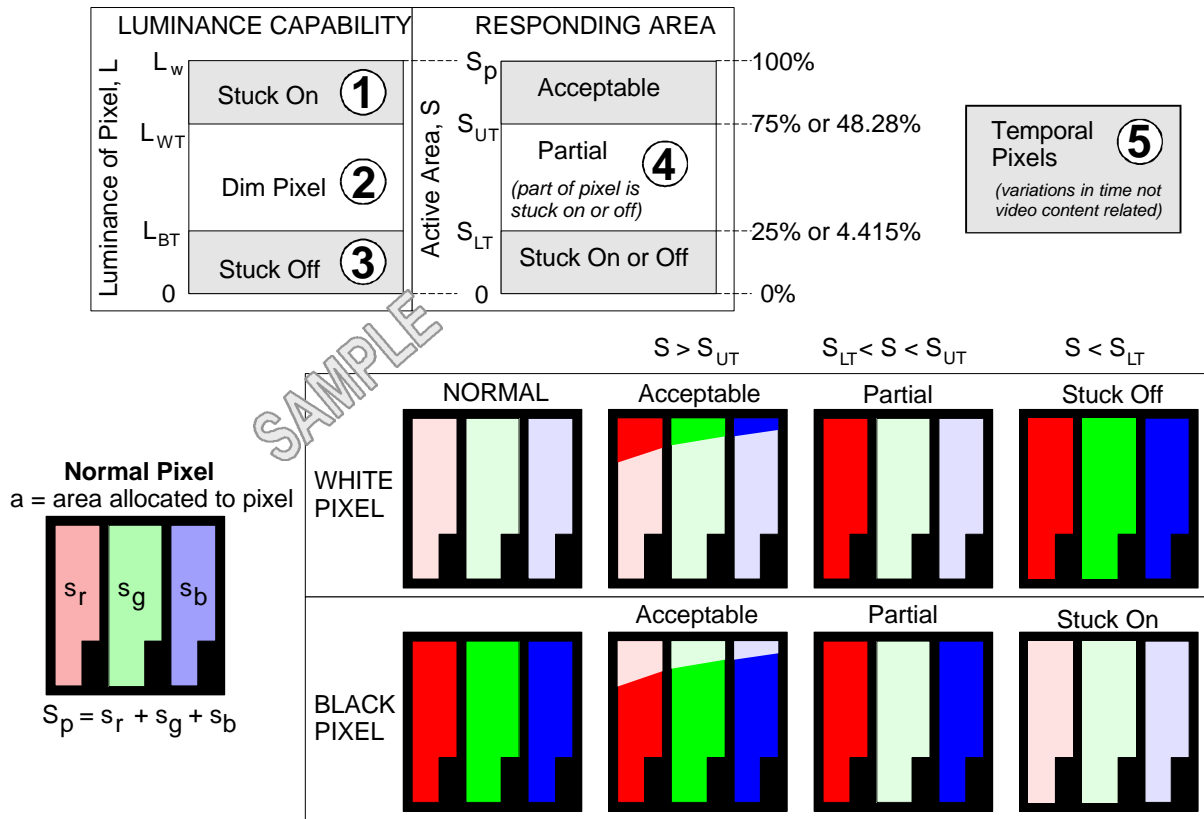
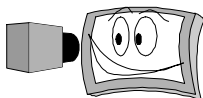
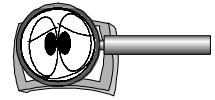


Fig. 1. Example of a hypothetical TFT LCD subpixel configuration.

**ANALYSIS:** In any final reported result, all fractional pixels are rounded up to a whole number. Five types or classifications define defective pixels. Type 1, 2, and 3 are luminance-related, type 4 is spatially related, and type 5 is temporally related. There is a white threshold level  $L_{WT}$ , a black threshold level  $L_{BT}$ , a partial-pixel-area upper threshold  $S_{UT}$ , and a partial-pixel-area lower threshold  $S_{LT}$ , upon which these classifications are based:

- 1) **On Pixels (Stuck On):** Luminance always above the white threshold independent of video content,  $L > L_{WT}$ . Can be observed using a black screen. These pixels appear as bright pixels on a black background.





- 2) **Dim Pixels (Stuck Dim):** Luminance is always between the white threshold and the black threshold independent of video content,  $L_{BT} < L < L_{WT}$ . They can be observed using a white and then a black screen. These pixels appear as a gray pixel independent of a white or black background.
- 3) **Off Pixels (Stuck Off):** Luminance is always below the black threshold,  $L < L_{BT}$ . They can be observed using a white screen. These pixels appear as dark pixels on a white screen.
- 4) **Partial Pixels:** Pixels that have defective subpixels or area defects within a pixel, e.g., part of the pixel is stuck on or off. If  $S_p$  is the light producing area of a normal pixel, e.g. the combined area of the subpixels, then there are three active-area regimes in which the pixel can operate: (1) The active area  $S$  of the pixel is less than the lower threshold  $S < S_{LT}$ , in which case the pixel is mostly inoperative and stuck either on or off. (2) The active area of the pixel is greater than the upper threshold  $S > S_{UT}$ , in which case the pixel is mostly operational and not to be considered a defective pixel. (3) The case of the partial pixel where the active area of the pixel is between the threshold limits  $S_{LT} < S < S_{UT}$ .
- 5) **Temporal Pixels:** Pixels that exhibit temporal variations not related to any steady-state video input. Temporal pixel defects may be intermittent, exhibit a sudden change of state, or be flickering. They can be observed using a white and/or a black screen.

(Note: For equating pixel defect types to those defined by ISO 13406[2], the ISO type 3 can be considered to be the combination of the type 3, 4, and 5 defined in this document.)

A complete pixel defect specification would include setting limits for each type of defect  $n_i$ . The total number of defects is given by the sum

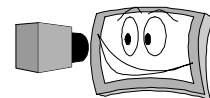
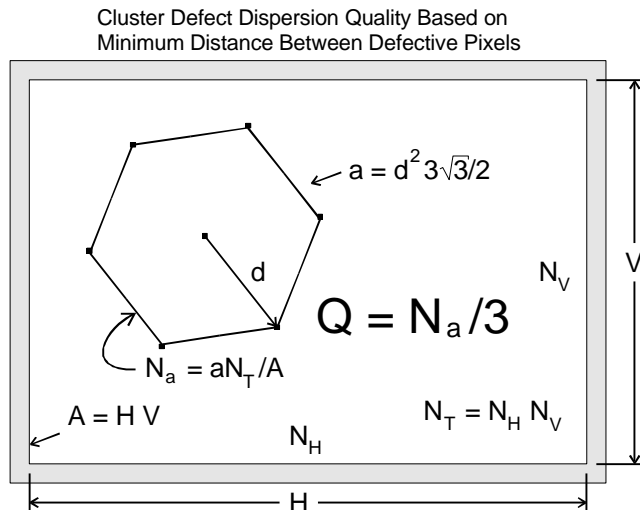
$$n_T = \sum_{i=1}^5 n_i \tag{1}$$

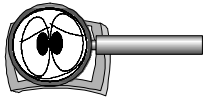
These defects are not likely to evenly distribute themselves about the screen. There may be some bunching. This leads to the idea of clustering specifications as well as defect counts.

Defect Analysis Reporting Template						
Criteria	Lower Thresholds (%)	$L_{BT}, S_{LT}$	Upper Thresholds (%)	$L_{WT}, S_{UT}$		Clustering Quality
Type	1	2	3	4	5	Defect Dispersion Quality
Name	Stuck On	Dim	Stuck Off	Partial	Temporal	
Number Allowed	$n_1$	$n_2$	$n_3$	$n_4$	$n_5$	<b>Q</b>
Patterns:	(Describe screens used and any special method.)					

### 303-6b Clustering Characterization and Measurement

**Clustering of Defects:** Clustering of defects is a way of characterizing the proximity or grouping of pixel defects. If a certain display has  $n$  defective pixels, then the proximity of the pixels can affect how objectionable the defects are and the usability of the display. For example, 20 pixel defects scattered randomly on a 1024x768 display will not be nearly as objectionable as they would be if they were clustered or contained within a confined area,





such as within 10 % of the area of the display. If a total of  $n_T$  defective pixels were distributed absolutely uniformly about the surface of the display, then the minimum defect density would be  $n_T/N_T$ . Note that the area of the display is not in the denominator, but the total number of pixels for the display. This density is a density of defective pixels compared to the total number of pixels  $N_T = N_H N_V$ ; therefore, this density is independent of display size. For example, if we allow  $n_T = 20$  px and we have a  $1024 \times 768$  screen, then the density would be  $2.57 \times 10^{-4} = 1/3891$  defective pixels per screen pixels. However, given that we have  $n_T$  defective pixels,  $n_T/N_T$  is the absolute lowest pixel density that may be obtained. Clearly that will not be the case in general. Therefore, we will expect that the clustering density specification will allow a higher pixel density than this minimum, probably significantly higher. Densities are not always very intuitive, so we introduce a **defect dispersion quality** metric as the inverse of the density:

*Defect dispersion quality or Clustering Quality:*  
 $Q$  = the number of acceptable pixels for each defective cluster pixel.

Often we will use “**clustering quality**” as a short name for  $Q$ . The clustering quality is the inverse of the clustering density. Given  $N_T$  as the total number of pixels in the display and  $n_T$  as the total number of defects, the maximum that the clustering quality can be is

$$Q_{\max} = N_T/n_T. \tag{2}$$

This is equivalent to requiring that the defects be absolutely uniformly spread over the surface of the screen—a situation that would be rarely obtained in practice.

Consider two defective pixels separated by a distance  $d$ . We want to develop an expression for the largest defect density based on that distance. The highest density is obtained by centering a hexagon on one pixel and imagining other pixels at the remaining vertices of the hexagon—all the pixels will be a distance  $d$  from each other, and the pattern can be repeated for the entire screen. How many pixels are there within the area of the hexagon? Image that the pixels were round and centered exactly at the vertices. One third of each vertex pixel lies within the hexagon. Thus, with six vertex pixels, one-third pixel each, plus the center pixel, we have the equivalent of three pixels per hexagon as worst-case packing. Obviously, this is an idealized case, but for large number of pixels, it should be adequate. The area of a hexagon with sides  $d$  is  $a = 3d^2 \sqrt{3}/2$ , and the number of pixels within  $a$  is  $N_a = aN_T / A$ . The clustering density is  $3/N_a$ , and the clustering quality is then  $Q = N_a/3$ . Of course, pixels don’t cluster in such a regular pattern. We can assume that they will randomly be distributed about the screen. We need to extend this to make it meaningful for randomly distributed pixels.

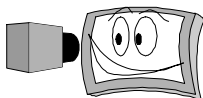
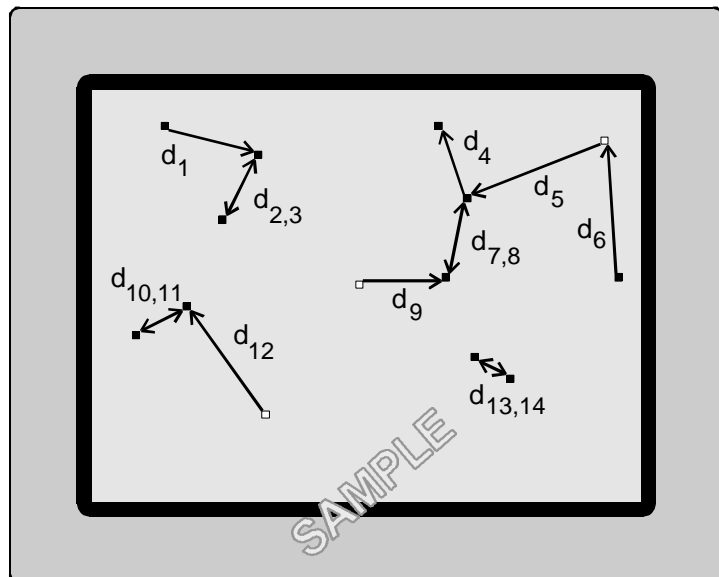
Consider a screen with defective pixels distributed randomly. We will assume square pixels. Each defective pixel  $i = 1, 2, \dots, n_T$ , will have a nearest neighbor a center-to-center distance  $d_i$  away. We define  $d$  to be the average nearest-neighbor distance between defective pixels or the mean minimum distance between defective pixels,

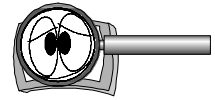
$$d = \frac{1}{n_T} \sum_{i=1}^{n_T} (d_i - P), \tag{3}$$

where we subtract the pixel pitch from each center-to-center distance  $d_i$  so that  $d$  goes to zero for all defective pixels touching each other in a row or column. In general, the  $P$  term will be of little consequence for many screens.

To determine the mean minimum distance between defective pixels, proceed as follows:

1. List the  $(x, y)$  position of all defective pixels in either a distance (e.g., in mm) or pixel coordinates.
2. For each defective pixel in the list, compute the minimum center-to-center distance to any other pixel in that list. Often a pair of nearby





defects will each have the same minimum distance to each other.

3. Compute the mean of the minimum center-to-center distances. If you use pixel coordinates instead of pixel distances, convert the pixel coordinates to a distance by multiplying the mean result by the pixel pitch  $P$ .

$$d_i \text{ measured in units of distance: } d = \frac{1}{n_T} \sum_{i=1}^{n_T} (d_i - P), \quad (4)$$

$$d_i \text{ measured in units of pixel coordinates: } d = \frac{P}{n_T} \sum_{i=1}^{n_T} (d_i - 1). \quad (5)$$

**NOTE:** If you are attempting to determine that a candidate DUT meets its specified clustering criterion  $Q$ , first locate the closest two defective pixels and determine their separation  $d'$ ; if the clustering quality factor  $Q'$  based on this distance  $d'$ ,  $Q' = d'^2 N_T \sqrt{3} / (2A)$  is greater than or equal to the specification requirement,  $Q' \geq Q$ , then it is not necessary to measure the distances between the rest of the defective pixels. The display definitely meets or exceeds the specified clustering quality. Alternatively, you can cut a circular hole in a piece of paper having a diameter of

$$d = \sqrt{(2QA) / (N_T \sqrt{3})}, \quad (6)$$

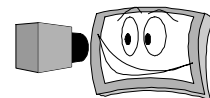
and search to see any two defective pixels can be found to fall within the circle. If not, then the display definitely meets or exceeds the clustering quality criterion. If using either of these tests, two pixels are found to be closer than  $d$  it does *not* mean that the display does not meet the clustering criterion. It simply means that a more thorough analysis will be required to determine the clustering quality, as described above.

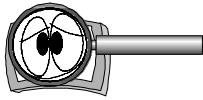
With this definition, the clustering can be defined by the average distance between defective pixels  $d$  or by the clustering quality  $Q$ . Assuming square pixels, there are two more ways to express clustering: the smallest fraction of the horizontal screen size permitted between defective pixels  $f = d/H$ , and the minimum number of horizontal pixels  $n_d = d/P$  permitted between defective pixels ( $P$  is the pixel pitch for square pixels).

If square pixels are not used, the formulation will work well replacing  $P$  with  $P' = \sqrt{P_H^2 + P_V^2}$ , provided  $d$  is confined to being always positive (in the event that all pixels touch or nearly touch—again, we can hardly expect this to be a routine problem).

**PROCEDURE:** There are two cases, you are trying to measure the clustering quality of a display or you are trying to specify the clustering quality of a display.

**Measurement of Clustering Quality:** Follow the three steps leading to Eqs. 4 and 5 to obtain the mean minimum distance between defective pixels  $d$ . The clustering quality is then  $Q = \frac{d^2 N_T \sqrt{3}}{2A}$ , where  $N_T$  is the total number of pixels making up the display and  $A$  is the area of the display. See the table for other means of determination  $d$  and  $Q$  when  $d$  is measured in the fraction of screen width or the number of pixels between defects.





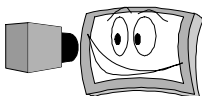
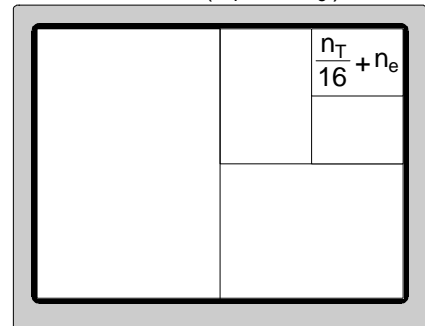
**Table 1.** Relationships Regarding Clustering Quality  $Q$

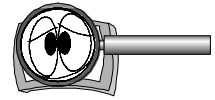
Based on $d$ (the mean nearest-neighbor distance or mean minimum distance between defective pixels)		
$Q = \frac{N_a}{3}$	Clustering quality	Number of acceptable pixels for three ideal defective pixels distributed uniformly—this is the basis of the model.
$Q = \frac{aN_T}{3A}$	Clustering quality	Clustering quality in terms of the area $a$ of a hexagon, the total number of pixels, and the area of the screen.
$a = \frac{d^2 3\sqrt{3}}{2}$	Area of hexagon with side $d$ .	
$Q = \frac{d^2 N_T \sqrt{3}}{2A}$	Clustering quality	Clustering quality expressed in terms of the mean minimum distance between defective pixels. <b>Measure <math>d</math>, calculate <math>Q</math>.</b>
$d = \sqrt{\frac{2QA}{N_T \sqrt{3}}}$	Mean minimum distance between defective pixels	Should you know $Q$ and you want to determine the mean minimum distance $d$ upon which the determination was made. <b>Given <math>Q</math>, determine <math>d</math>.</b>
$d = \frac{1}{n_T} \sum_{i=1}^{n_T} (d_i - P)$	$d$ measured in units of distance	
$d = \frac{P}{n_T} \sum_{i=1}^{n_T} (d_i - 1)$	$d$ measured in pixel coordinates	
Based on $f$ (the mean nearest-neighbor distance in terms of the fractional distance of the screen)		
$f = d / H$ , or $d = fH$	Characterizing $d$ by a fraction of the horizontal screen	
$Q = \frac{f^2 a N_T \sqrt{3}}{2}$ , derivation: $Q = \frac{d^2 N_T \sqrt{3}}{2A} = \frac{f^2 H^2 N_T \sqrt{3}}{2HV} = \frac{f^2 a N_T \sqrt{3}}{2}$		
Based on $n_d$ (the mean nearest-neighbor distance in terms of a number of pixels on the screen)		
$n_d = d/P$ , or $d = n_d P$	Characterizing $d$ by a number of pixels	
$Q = \frac{n_d^2 \sqrt{3}}{2}$ , derivation: $Q = \frac{d^2 N_T \sqrt{3}}{2A} = \frac{n_d^2 P^2 N_T \sqrt{3}}{2HV} = \frac{n_d^2 \sqrt{3}}{2}$		
Definitions used in the above:		
$N_a = aN_T/A$	Number of pixels in an area $a$	
$A = HV$	Area of the screen (the active, viewable, image-producing area)	
$N_T = N_H N_V$	Number of pixels on screen in terms of number of horizontal and vertical pixels	
$H = N_H P_H$ $H = N_H P$ (square pixels)	Number of horizontal pixels in terms of the horizontal pixel pitch	
$H = N_V P_V$ $H = N_V P$ (square pixels)	Number of vertical pixels in terms of the vertical pixel pitch	

**Determination of Requisite Clustering Quality:** An excellent way to estimate how many defects are tolerable is to subdivide the screen into boxes taking half of each box until you reach 1/16 the area. How many pixels will you tolerate in the small box? If you have already specified the total number of defects allowed  $n_T$ , then there can be  $n_T/16$  pixels plus some excess pixels  $n_e$ . You must select what  $n_e$  must be. The clustering quality is then  $Q = N_T/(n_T + 16n_e)$ . If you don't know what value for  $n_T$  is reasonable for your task, then you can specify how many defective pixels  $n$  you will tolerate in the 1/16 box, and then the clustering quality can be defined as  $Q = N_T/(16n)$ .

*Discussion:* Here you have some idea of how many defective pixels you will tolerate, that is, you know  $n_i$  ( $i = 1, 2, \dots, 5$ ) and  $n_T$ , or you know how many pixels you will tolerate in a 1/16 box. You probably will never dare require an absolute uniform distribution of

$$Q = N_T / (n_T + 16n_e)$$





defects using  $Q_{\max} = N_T/n_T = 39322$ , so what we need is a way to estimate a reasonable value if  $Q$ . It may be tempting to select a distance  $d$  and then calculate  $Q = d^2 N_T \sqrt{3}/2A$ . This can be done but it will probably not yield what you want. Consider an example. Suppose we desire a 1024×768 pixel screen having a horizontal size of 245 mm and vertical size of 184 mm, and we want  $d = 20$  mm to be the mean minimum distance between defects. This gives  $Q = 6043$ , and for the entire area  $A$  at that density of defects, we could have 130 defective pixels. So, let's say you limit the total number of defects to  $n_T = 20$  and you think you've taken care of the problem. Not so, for all the pixels could be clustered in one region of the screen all with a distance  $d$  between them, and that is probably not what you want either. Now use the 1/16 box: if the defects were evenly distributed, we'd find  $n_T/16 = 1.25$  pixels per 1/16 box. If you will allow one more pixel  $n_e = 1$ , then  $Q = 21845$ ; if  $n_e = 2$ , then  $Q = 15124$ . This in itself may not adequately solve the problem of specification, for even under the condition of using the 1/16 box criterion, you can still have two pixels touching and meet the cluster quality criterion established by the 1/16 box criterion. This is why we introduce the minimum defect separation below in 303-6c.

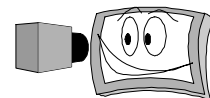
**Extension to More Complicated Clustering Quality Factors:** Clearly, should it be necessary and if a more detailed clustering description is required, a clustering quality could be defined for each type of pixel defect. Another way to deal with the different types of pixel defects if they are not considered equally objectionable, is to use a weighting factor  $w_i$  in the expression of the mean minimum distance between

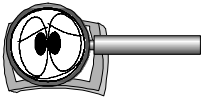
defective pixels:  $d = \frac{1}{n_T} \sum_{i=1}^{n_T} w_i w_j (d_i - P)$ , where  $w_i$  is the weighting factor for the  $i^{\text{th}}$  pixel and  $w_j$  is the

weighting factor for the its nearest neighbor, the  $j^{\text{th}}$  defective pixel. For example, the weights might be 1 for a stuck-on or stuck-off pixel, 1/2 for a dim pixel, 1/3 for a partial pixel, and 1 for a temporal pixel.

### 303-6c Minimum Defect Separation — $d_{\min}$

If two defective pixels are very close together and all other defective pixels are widely separated, the clustering quality may be met and the number of defective pixel types may also be met, but the fact that the two defective pixels are so close together may be objectionable. Thus, the minimum allowable distance between defective pixels  $d_{\min}$  may also be specified if it is necessary to do so. Again, this minimum distance can be specified in terms of the distance on the screen, the number of pixels in the separation, or the fractional width of the horizontal screen.





## 303-7 RESOLUTION FROM CONTRAST MODULATION

(effective resolution)

**DESCRIPTION:** We measure the resolution capabilities of a display compared to its addressability based on a threshold contrast modulation (Michelson contrast) associated with grille patterns.

**Addressability** refers to the number of pixels that can be separately controlled. **Resolution** refers to how well those pixels can appear separate and distinct to the eye. Describing resolution with a simple number, such as 1600 x 1200 pixels, is an approximation to a complicated subject. We define resolution here as the number of alternate black and white lines that can be displayed with a stated minimum contrast modulation (Michelson contrast), the threshold contrast modulation  $C_T$ . If the display fails to meet this criterion for a specified addressability, then the addressability cannot be claimed as resolution in describing the display—the actual resolution would be lower than the addressability. In the case of a CRT, displaying more pixels than that will lower the contrast modulation below the minimum acceptable visibility of lines. In the case of discrete-pixel FPDs, such lowering of the resolution capabilities can arise from excessive inter-pixel crosstalk. Here, the contrast modulation is defined as:

$$C_m = \frac{L_w - L_b}{L_w + L_b}$$

We use two criteria to allow us to assign meaningful numbers to realizable resolution for two common applications. We examine the values for horizontal and vertical resolution separately.

*Text resolution* (and graphics) require crisp edge definition and clear whites and blacks. We define the resolution for this use as the maximum number of alternating black and white lines that can be displayed with a threshold contrast modulation  $C_T$  of 50 % or more. A contrast modulation of 50 % produces alternating lines that are highly visible.

*Image resolution* typically does not require sharp changes in luminance. For monitors displaying images rather than text, we define the resolution using a minimum  $C_T$  of only 25 %. A pattern of alternating black and white lines with 25 % contrast modulation is still visible.

Demanding a higher contrast modulation threshold for text than for images can mean that the claimed resolution may be lower for text in some cases. Two thresholds are suggested above depending upon the task. Other thresholds may be used if necessary provided all interested parties are in agreement. Different tasks may require different thresholds to be used.

**SETUP:** None. Measurements of  $N \times N$  grille contrast modulations are specified in 303-2.

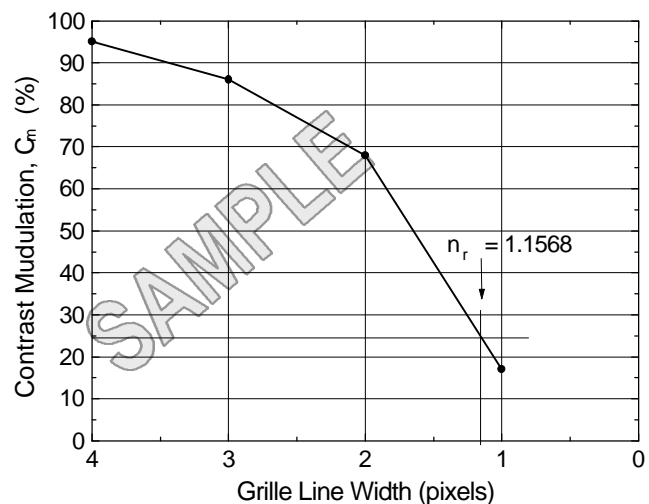
**PROCEDURE:** None. Measurements of  $N \times N$  grille contrast modulations are made in 303-2.

**ANALYSIS:** Calculate the resolution in number of resolvable pixels:

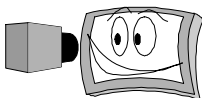
$$\text{Resolution} = \frac{\text{\# of Addressable Lines}}{n_r}$$

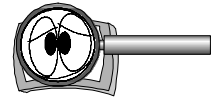
where  $n_r$  is the calculated grille line width in pixels for which the value of  $C_m$  is estimated by linear interpolation to be equal to the contrast modulation threshold  $C_T$ , for example, 25 % as depicted in Fig. 1.  $C_m(n)$  specifies the contrast modulation from an  $n \times n$  grille.

If  $C_m(1) > C_T$  (e.g., 25 %), then  $n_r = 1$  and the resolution is equal to the number of addressable pixels. For  $C_m(1) < C_T$ , use linear interpolation to calculate the value of  $n_r$  from the measured  $C_m$  values nearest to the threshold  $C_T$  (e.g., 25 %). In general, use



**Fig. 1.** Use linear interpolation to determine the value of  $n_r$  from contrast modulation measurements.





values of  $C_m$  such that  $C_m(n) < C_T < C_m(n+1)$ , measured for grille patterns of  $n$ -pixels wide lines and  $(n+1)$ -pixels wide lines.

$$n_r = n + \frac{C_T - C_m(n)}{C_m(n+1) - C_m(n)}, \text{ for } C_m(n) < C_T < C_m(n+1)$$

**Example:** Let  $C_T = 25\%$ ,  $C_m = 17\%$  for 1-pixel grille patterns, and  $C_m = 68\%$  for 2-pixel grille patterns. Interpolate between these two data points to calculate the value of  $n_r$  for 25% modulation, that is, using  $C_T = 25\%$ : for  $n = 1$ ,  $C_m(1) = 0.17$ ;  $C_m(2) = 0.68$ . For these values,  $n_r$  and the resolution are found to be

$$n_r = n + \frac{C_T - C_m(n)}{C_m(n+1) - C_m(n)} = 1 + \frac{0.25 - 0.17}{0.68 - 0.17} = 1.1568$$

$$\text{Resolution} = \frac{\text{\# of Addressable Lines}}{n_r} = \frac{1024}{1.1568} = 885 \text{ lines.}$$

Apply this criterion to the measured contrast modulation data  $C_m$  to assess the resolution capabilities of the display in units of pixels in both horizontal and vertical directions.

**REPORTING:** Report the integer number of resolvable pixels using the values of  $C_m$  obtained in previous sections. Report as a pair of numbers for horizontal and vertical directions,  $C_{mH} \times C_{mV}$ , for each measurement location on the screen required.

Worst location is defined as the test location on the screen where the minimum combined horizontal and vertical contrast modulation occurs. The combined contrast modulation is the magnitude calculated using the root-mean-of-squares:

$$C_m = \sqrt{(C_{mH}^2 + C_{mV}^2)/2},$$

where  $C_{mH}$  is horizontal contrast modulation and  $C_{mV}$  is vertical contrast modulation of white lines.

**COMMENTS:** Resolution is often the first specification one asks about a display. It is essential to distinguish between the concepts of *addressability* and *resolution*:

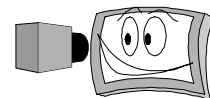
- **Addressability** states the number of locations at which a pixel (dot) can be displayed on the screen. However, that does not guarantee that the spot of light is small enough to actually *distinguish* adjacent addressable spots.
- **Resolution** is the number of pixels (or lines) that can be adequately distinguished across the screen.
- **Contrast modulation**  $C_m$  is considered by some to be the best and most complete single-metric description of the ability of a display to exhibit information.

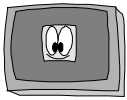
If the display were perfect, the screen would show a series of full white bars with perfectly black bars between them, yielding a  $C_m$  of 100%. In reality, several factors combine to spread the light out so that the pattern is one of light and dark gray bars, not black and white. Among these are:

- The ability of the display to form a narrow line, e.g., problems with crosstalk.
- The accuracy with which the three color beams merge together (in the case of a CRT).
- Halation – the leakage of light from bright areas of the image into the dark areas because of reflections off the covering material, the interior parts of the display, and the display pixel surface.

A pixel definition based solely on  $C_m$  relies only on relative peak and valley luminances independent of absolute luminance. The ANSI pixel defined in ANSI/NAPM IT7-215 limits the allowable luminance rolloff at higher frequencies by requiring the peak luminance of the display at the highest spatial frequency does not degrade below 30% of the low-frequency peak luminance, specifically that of the 4 x 4 checkerboard pattern. The ANSI pixel modulation is defined as the (peak - valley) luminance of a 1-on/1-off grille relative to the (white - black) luminance of the ANSI large-area 4 x 4 checker board test pattern. Using linear interpolation, an estimate of the ANSI pixel can be computed using results obtained by measurement procedures described in FPDM Sections 303-2 (NxN Grille Contrast Ratio) and 303-9 (Checkerboard Contrast Ratio).

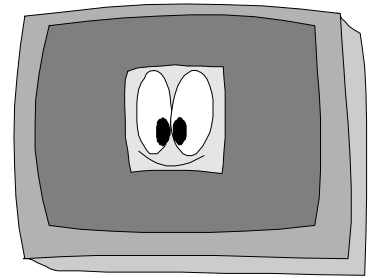
Reporting Results — Sample Data			
Threshold:	25 (0.25)		
Horizontal		Vertical	
$C_{mH}$ 1x1	0.17	$C_{mV}$ 1x1	0.34
$C_{mH}$ 2x2	0.68	$C_{mV}$ 2x2	0.88
$C_{mH}$ 3x3	0.86	$C_{mV}$ 3x3	0.94
$C_{mH}$ 4x4	0.95	$C_{mV}$ 4x4	0.98
$n$	1	$n$	
$n_r$	1.157	$n_r$	1
Addressability	1024	Addressability	768
Resolution	885	Resolution	768





## 304 BOX-PATTERN MEASUREMENTS

Box-pattern measurements refer to placing rectangular boxes on the screen and comparing one box with another, with the background, or combinations of boxes. There are three kinds of measurements outlined below. Note cautions and conventions described in the boxes at the base of the page. Box contrast measurements are to be made as additional measurements. They should never be substituted for full-screen contrast measurements for any direct-view display (with the exception of projection systems). Also, be careful whenever a measurement of black is made when white is present on the screen. Use a cone mask to eliminate light corruption of black; see A101 (Veiling-Glare and Lens-Flare Errors). We often specify fixed-box sizes of 1/5 to 1/6 of the screen linear dimensions. There may be occasions where other fixed-box sizes are required. All reporting documentation must clearly specify a departure from this specification, and all interested parties must agree to the change.



### CENTERED BOX MEASUREMENTS

- 304-1 LUMINANCE & CONTRAST OF BOX
- 304-2 CENTERED BOX ON-OFF LUMINANCE & CONTRAST
- 304-3 TRANSVERSE CONTRAST OF BOX
- 304-4 GRAY SCALE OF BOX
- 304-5 COLOR GAMUT OF BOX
- 304-6 COLOR SCALES OF BOX

### CENTERED BOX OF VARIABLE SIZE

- 304-7 HALATION
- 304-8 LUMINANCE LOADING

### FULL-SCREEN BOX PATTERNS

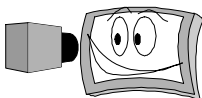
- 304-9 CHECKERBOARD LUMINANCE AND CONTRAST ( $n \times m$ )

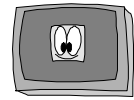
**WARNING:** When making measurements with white areas on the screen the black measurement can be grossly inaccurate unless proper accounting (and/or correction) is made for veiling glare or lens flare (A101-1).

**NOTE:** The full-screen contrast ratio is the contrast metric that is always assumed unless specified otherwise for direct-view display technologies (not necessarily projection systems or any display that places a lens between the pixel surface and the viewed image—head-mount, head-up, etc.). Any other contrast metric must be properly identified explicitly if it is not this full-screen contrast ratio. We strongly suggest the above  $C_R$  in any characterization of direct-view displays. If a non-perpendicular viewing angle is used it must be reported with the contrast value.

For example, if someone simply says that the contrast of their display is such-and-such, it must be referring to the full-screen  $C_R$  above. If a box contrast is used then it must be stated “the box contrast is...,” similarly for a 4 x 4 checkerboard contrast, “the 4 x 4 checkerboard contrast is...” In any case we strongly suggest that the above  $C_R$  always be reported.

If a viewing angle is employed such as 4° up vertically and  $C_R = 400$  whereas  $C_R = 250$  for the perpendicular we report as “The viewing contrast at 4° vertically up from perpendicular is 400:1,” or “400:1 at 4° up.” If the contrast at perpendicular is also included, state it clearly: “The contrast at the perpendicular is 250:1,” or “250:1 at 0°.”





# 304-1 LUMINANCE & CONTRAST OF CENTERED BOX

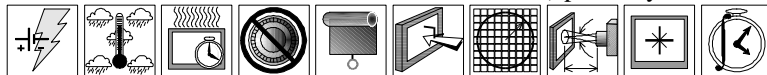
**DESCRIPTION:** We measure the luminance of the center of a white centered box 1/5 to 1/6 the size of the diagonal with a black background. (Optionally: a black box of the same size on a white background.) The surrounding black screen is measured at eight positions and the average, maximum, and minimum contrast is calculated.

**Units:** none. **Symbol:**  $C_B$ .

Box contrast ratios can be different than full-screen contrast ratios because of loading effects of the display. Sometimes it is desired to know how the contrast performance of the display changes from full screen to a small area.

**SETUP:** Arrange to measure the center luminance of a white box centered - on the screen (negative pattern) and the surrounding black area. (Optionally a positive pattern with a black box with a white background may additionally be measured.) The box should be in the range of 1/5 to 1/6 the diagonal of the screen. Arrange to measure the surrounding black area at eight points surrounding the white box at a distance of the size of the box from the center of the screen (see the figure). See Section 301 for any standard setup details.

**SPECIFIC:** Pattern: Centered white box on black (optionally black box on white).



**PROCEDURE:** Measure the luminance of the center  $L_C$  of the box where we define  $L_C \equiv L_5$ . For contrast measurements, determine the luminance of the black surround at the eight points ( $L_i, i = 1,2,3,4,6,7,8,9, i \neq 5$ ) half the thickness of the box away from the box (see figure). Be sure to avoid glare contamination of the black measurement. It is suggested that a black-gloss cone mask be used to prevent glare. See Veiling-Glare and Lens-Flare Errors (A101) for details on measurements of black in the presence of white.

**ANALYSIS:** Calculation of the contrast ratio given by the white luminance divided by the black luminance:  $C_B = L_w/L_b$ . The box contrast ratio is the average of the eight readings. Also determine the maximum and minimum contrasts  $C_{Bmax}, C_{Bmin}$ .

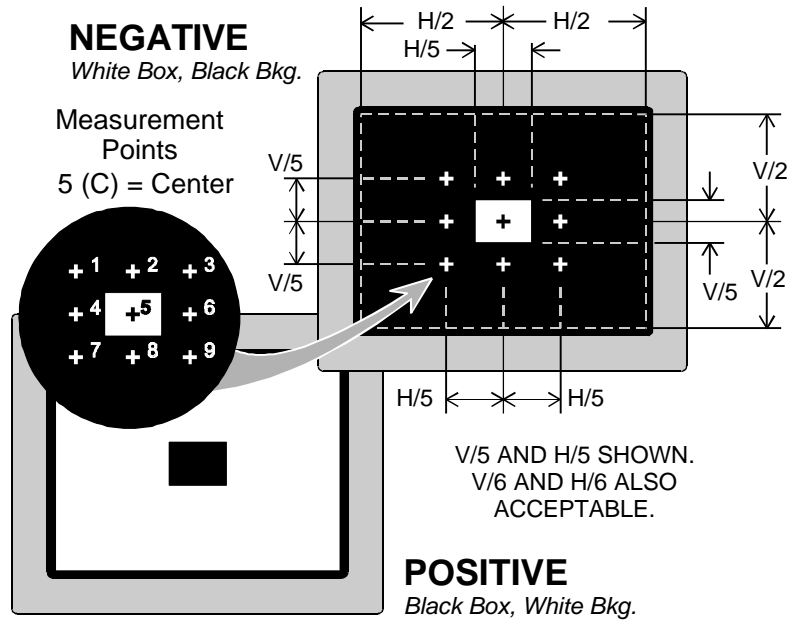
Negative: White box on black background:

$$\text{NEGATIVE: } C_B = \frac{8L_C}{\sum_{i \neq 5} L_i}, \quad C_{Bmin} = \frac{L_C}{L_{max}}, \quad C_{Bmax} = \frac{L_C}{L_{min}};$$

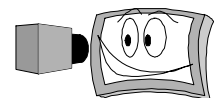
Optionally: Positive: Black box on white background:

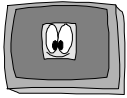
$$\text{POSITIVE (optional): } C'_B = \frac{1}{8L_C} \sum_{i \neq 5} L'_i, \quad C'_{Bmin} = \frac{L'_{min}}{L'_C}, \quad C'_{Bmax} = \frac{L'_{max}}{L'_C};$$

where the implicit sum is over  $i = 1, 2, 3, 4, 6, 7, 8, 9 (i \neq 5)$ ,  $L_{min}$  and  $L_{max}$  are the minimum and maximum luminances of the eight black luminance measurements made in the black background,  $L_{min} = \min(L_i)$ ,



**WARNING:** When making measurements using the (optional) positive pattern, the black measurement can be grossly inaccurate unless proper accounting (and/or correction) is made for veiling glare or lens flare (A101-1).





$L_{\max} = \max(L_i)$ . Similarly, if the positive pattern is (optionally) also measured,  $L'_{\min}$  and  $L'_{\max}$  are the minimum and maximum white luminance of the eight white luminance measurements made in the white background.

**REPORTING:** Report the luminance of the centered box. For contrast measurements, report the luminance of the eight black readings and the separate contrasts obtained. Also report the average as the box contrast ratio  $C_B$ . Report all contrasts to no more than three significant figures. Be sure that the significant figures of the box contrast ratio does not exceed the significant figures of the black measurements.

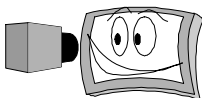
Analysis and Reporting of Sample Data		
Pattern:	Negative: White on Black	
Black at 1	Black at 2	Black at 3
0.45 cd/m <sup>2</sup>	0.71 cd/m <sup>2</sup>	0.42 cd/m <sup>2</sup>
330:1	210:1	360:1
Black at 4	White luminance	Black at 6
0.68 cd/m <sup>2</sup>	151 cd/m <sup>2</sup>	0.62 cd/m <sup>2</sup>
220:1	Ave.: $C_B = 270:1$	240:1
Black at 7	Black at 8	Black at 9
0.49 cd/m <sup>2</sup>	0.64 cd/m <sup>2</sup>	0.51 cd/m <sup>2</sup>
310:1	230:1	290:1

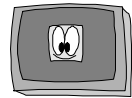
**COMMENTS:** Be careful of making black measurements in the presence of white. See Veiling-Glare and Lens-Flare Errors (A101) for details. Be careful with the use of masks since reflections off the mask can also corrupt the black measurement. A black-gloss cone mask is suggested.

**NOTE:** The full-screen contrast ratio is the contrast metric that is always assumed unless specified otherwise for direct-view display technologies (not necessarily projection systems or any display that places a lens between the pixel surface and the viewed image—head-mount, head-up, etc.). Any other contrast metric must be properly identified explicitly if it is not this full-screen contrast ratio. We strongly suggest the above  $C_R$  in any characterization of direct-view displays. If a non-perpendicular viewing angle is used it must be reported with the contrast value.

For example, if someone simply says that the contrast of their display is such-and-such, it must be referring to the full-screen  $C_R$  above. If a box contrast is used then it must be stated “the box contrast is...,” similarly for a 4 x 4 checkerboard contrast, “the 4 x 4 checkerboard contrast is...” In any case we strongly suggest that the above  $C_R$  always be reported.

If a viewing angle is employed such as 4° up vertically and  $C_R = 400$  whereas  $C_R = 250$  for the perpendicular we report as “The viewing contrast at 4° vertically up from perpendicular is 400:1,” or “400:1 at 4° up.” If the contrast at perpendicular is also included, state it clearly: “The contrast at the perpendicular is 250:1,” or “250:1 at 0°.”





## 304-2 CENTERED BOX ON-OFF LUMINANCE & CONTRAST

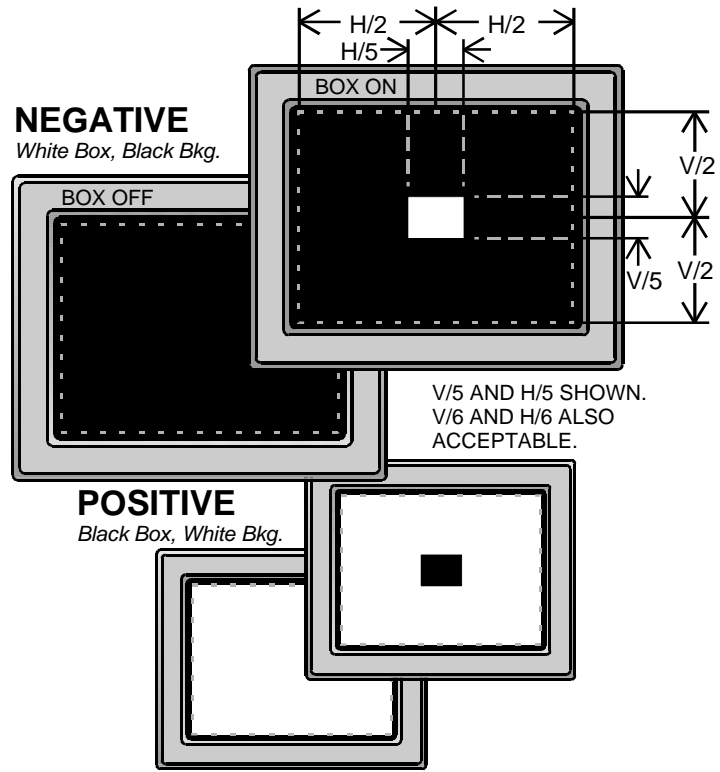
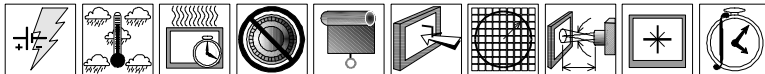
**DESCRIPTION:** We measure the contrast ratio of a white centered box 1/5 to 1/6 the size of the diagonal against a full black screen (optionally a black box on white screen). **Units:** none. **Symbol:** none.

Box contrast ratios can be different than full-screen contrast ratios because of loading effects of the display or other factors. Sometimes it is desired to know how the performance of the display changes from full screen to a small area.

The box contrast is the ratio of luminance of the white box to the luminance of the black background  $C_B = L_w/L_b$ . This is the negative pattern (white box on black). Additionally a positive pattern can be employed to determine the box contrast for a black box on a white screen  $C_B = L_w/L_b$ , or the positive pattern.

**SETUP:** Arrange to measure the center luminance of a white box centered on the screen and a black screen without the box. The box should be in the range of 1/5 to 1/6 the diagonal of the screen. See Section 301 for any standard setup details.

**SPECIFIC:** Centered white box, then black screen.



**PROCEDURE:** Measure the luminance of the center of the box  $L_w$ . Turn off the box and measure the luminance of the full black screen  $L_b$ .

**ANALYSIS:** Calculate the contrast ratio:  $C_B$  (and optionally  $C'_B$ ) according to Eq. 1.

**REPORTING:** Report the contrast ratio as the on-off box contrast ratio.

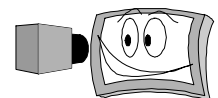
**COMMENTS:** Other sizes of rectangles may be used provided they are agreeable to all interested parties and are clearly reported in any document..

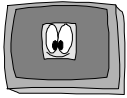
Analysis and Reporting	
$L_w$	0.732
$L_b$	94.3
$C_B$	129

**NOTE:** The full-screen contrast ratio is the contrast metric that is always assumed unless specified otherwise for direct-view display technologies (not necessarily projection systems or any display that places a lens between the pixel surface and the viewed image—head-mount, head-up, etc.). Any other contrast metric must be properly identified explicitly if it is not this full-screen contrast ratio. We strongly suggest the above  $C_R$  in any characterization of direct-view displays. If a non-perpendicular viewing angle is used it must be reported with the contrast value.

**WARNING:** When making measurements using the (optional) positive pattern, the black measurement can be grossly inaccurate unless proper accounting (and/or correction) is made for veiling glare or lens flare (A101-1).

OPTICAL





### 304-3 TRANSVERSE CONTRAST OF CENTERED BOX

(EIAJ's window contrast ratio)

**DESCRIPTION:** We measure the contrast ratio of a centered box 1/5 to 1/6 the size of the diagonal of the screen by measuring the luminance  $L_w$  of the center of the white box (box on = white) and measure the luminance  $L_b$  of the black at the same position with the box off (or full-screen black).

**NOTE:** This measurement is a subset of or contained within the measurements specified in 304-1 (Luminance and Contrast Ratio of Box).

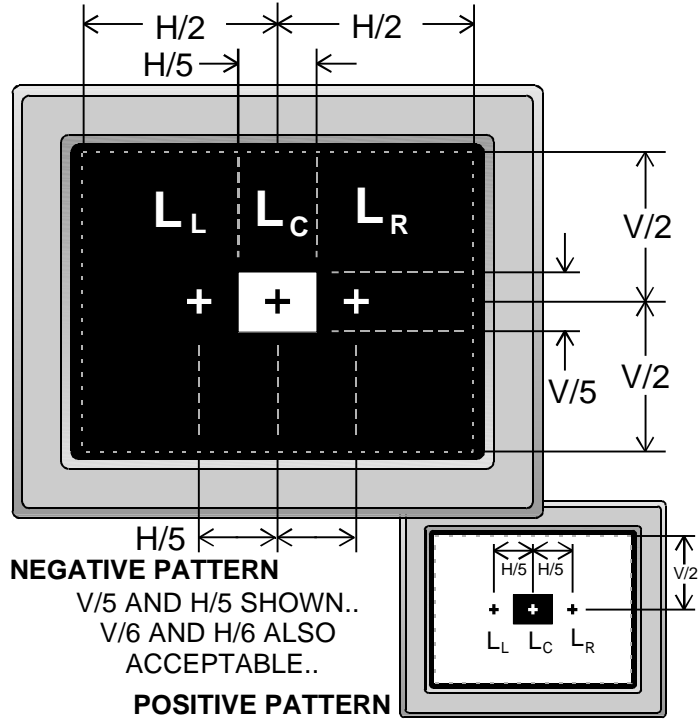
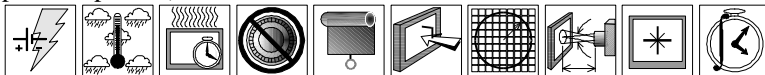
There are two configurations: negative, with a black background and white box; and the (optional) positive, with white background and black box. The contrasts of the negative box  $C_B$  and the positive box  $C'_B$  are given by

$$C_B = \frac{2L_C}{L_L + L_R}, \quad C'_B = \frac{L_L + L_R}{2L_C}, \quad (1)$$

where  $L_C$  is the luminance at the center position,  $L_L$  is the luminance at the left position, and  $L_R$  is the luminance at the right position. (The factor of two comes from the average of the two background measurements.)

**SETUP:** Arrange to measure the center luminance of a white box centered on a black screen (negative pattern). (And optionally the positive pattern.) The box should be in the range of 1/5 to 1/6 the diagonal of the screen. See Section 301 for any standard setup details.

**SPECIFIC:** Centered white box on black screen (and optionally inverse positive pattern).



Reporting Results (Sample Data)	
Pattern	egative (white ox)
$L_L$	0.451 cd/m <sup>2</sup>
$L_R$	0.492 cd/m <sup>2</sup>
$L_C$	95.6 cd/m <sup>2</sup>
$C_B$	101

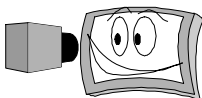
**PROCEDURE:** Measure the center luminance of the white box. Then measure the black luminance of on each horizontal side of the box at a distance of one half the box size from the edge of the box.

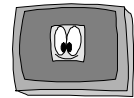
**ANALYSIS AND REPORTING:** Calculate the box contrast  $C_B$  according to Eq. 1. (Optionally add  $C'_B$ .)

**COMMENTS:** Be careful in making the black measurement. Avoid glare corruption of black by using a black-gloss cone mask. See Veiling-Glare and Lens-Flare Errors (A101) for details on measurements of black in the presence of white.

**NOTE:** The full-screen contrast ratio is the contrast metric that is always assumed unless specified otherwise for direct-view display technologies (not necessarily projection systems or any display that places a lens between the pixel surface and the viewed image—head-mount, head-up, etc.). Any other contrast metric must be properly identified explicitly if it is not this full-screen contrast ratio. We strongly suggest the above  $C_R$  in any characterization of direct-view displays. If a non-perpendicular viewing angle is used it must be reported with the contrast value.

**WARNING:** When making measurements using the (optional) positive pattern, the black measurement can be grossly inaccurate unless proper accounting (and/or correction) is made for veiling glare or lens flare (A101-1).

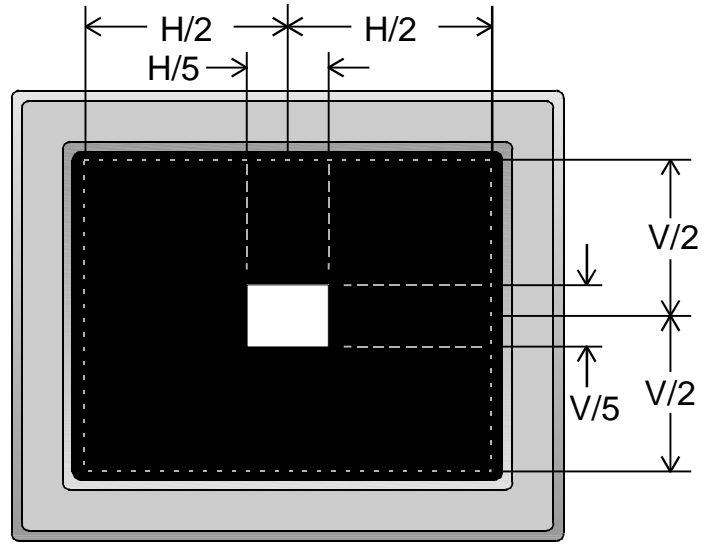




## 304-4 GRAY SCALE OF CENTERED BOX

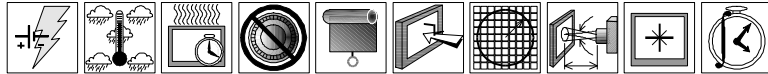
**DESCRIPTION:** We measure the luminance of a gray box for eight (optionally 16 or more) gray levels from white to black. A gamma value can be determined if appropriate. See Gray Scale of Full Screen (302-5).

**SETUP:** Arrange to measure the center luminance of a box centered on the screen for eight (optionally 16 or more) gray levels for the box from white to black. The box should be in the range of 1/5 to 1/6 the diagonal of the screen. See Gray Scale of Full Screen (302-5) for details on establishing the gray scale. See Section 301 for any standard setup details.



V/5 AND H/5 SHOWN. V/6 AND H/6 ALSO ACCEPTABLE.

**SPECIFIC:** Centered white box, then black screen.



**PROCEDURE:** Measure the center box luminance of each of the gray levels from white to black.

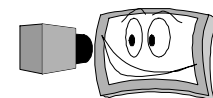
**ANALYSIS:** See the section on Gray Scale of Full Screen (302-5) for any analysis and, optionally, a determination of a gamma value.

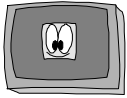
**REPORTING:** Report all the gray luminance levels. Optionally report any gamma value. See Gray Scale of Full Screen (302-5) for examples.

**COMMENTS:** See Gray Scale of Full Screen (302-5) for comments regarding the gamma value.



RUSTIC METROLOGY





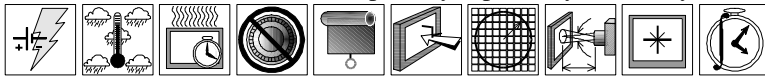
### 304-5 COLOR GAMUT OF CENTERED BOX

**DESCRIPTION:** We measure the luminance and chromaticity coordinates (gamut) of a centered box 1/5 to 1/6 the size of the diagonal for all the primary (optionally secondary) colors at the center of the screen.

See the section on Gamut and Colors of Full Screen (302-4) for any details.

**SETUP:** Arrange to measure the center luminance and chromaticity coordinates of a box centered on the screen for all the fully saturated primary colors (optionally secondary colors). The box should be in the range of 1/5 to 1/6 the diagonal of the screen. See Section 301 for any standard setup details.

**SPECIFIC:** Centered box of each primary (optionally secondary) colors.



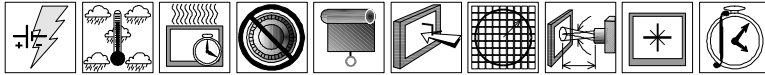
**PROCEDURE, ANALYSIS, REPORTING, and COMMENTS:** See the section on Gamut and Colors of Full Screen (302-4) for any details.

### 304-6 COLOR SCALES OF CENTERED BOX

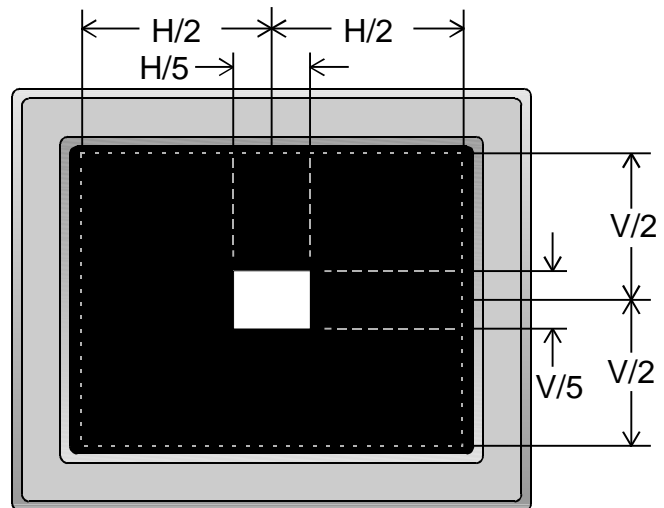
**DESCRIPTION:** We measure the luminance scale of the primary colors as eight (optionally 16 or more) box color levels go from the highest luminance of the color to black. Optionally, a gamma value may be determined for each color if appropriate.

**SETUP:** Arrange to measure the center luminance of a box centered on the screen for all the fully saturated primary colors (optionally secondary colors) for eight levels of color intensity. The box should be in the range of 1/5 to 1/6 the diagonal of the screen. See Section 301 for any standard setup details. See Color Scales of Full Screen (302-6) for further details.

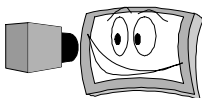
**SPECIFIC:** Centered box of each primary (optionally secondary) colors at eight levels.

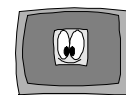


**PROCEDURE, ANALYSIS, REPORTING, and COMMENTS:** See Color Scales of Full Screen (302-6) for further details



V/5 AND H/5 SHOWN  
V/6 AND H/6 ALSO ACCEPTABLE.

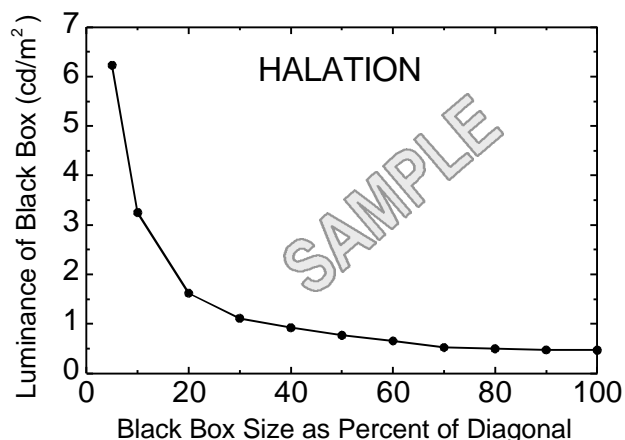
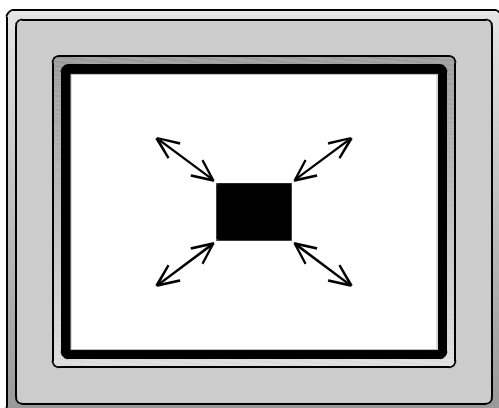




## 304-7 HALATION

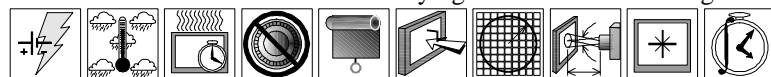
**DESCRIPTION:** We measure the luminance of a black box with a white background as the size of the box is adjusted from a small fraction of the screen to full screen.

Halation is said to occur when light from surrounding white areas corrupts a black area on the screen. This measurement is a method to characterize the amount of halation for a black box at the center of a white screen.



**SETUP:** Arrange for a box to vary in size from 5 % of the screen diagonal to the full screen. See Section 301 for any standard setup details.

**SPECIFIC:** Centered black box of varying sizes on a white background.



**PROCEDURE:** Use a sequence of centered black boxes on a white background with the size of the boxes being  $kH \times kV$  where  $k = 0.05, 0.1, 0.2, \dots, 0.9, 1.0$ . If the smaller boxes are less than 110 % of your minimum measurement FOV, arrange a cone mask (see A101) over the screen with a hole of diameter 0.045 times the lesser of the  $H$  or  $V$ , and make all measurement with the mask and LMD rigidly fixed in place. The readings won't reflect the true luminance, but we are only going to need ratios. Start with measuring the white full screen luminance and then do all the boxes. Plot the luminance of the box vs. the area of the box ( $HV k^2$ ) or the luminance of the box vs. the  $k$  factor (in percent or decimal).

**ANALYSIS & REPORTING:** Calculate the ratio of the difference between maximum box luminance  $L_{max}$  and the full-screen black luminance  $L_b$  to the full-screen white luminance  $L_w$  as the halation in percent  $100\%(L_{max} - L_b)/L_w$ .

**REPORTING:** Report the full-screen white and black luminances, the minimum box size used, the maximum box luminance (usually the smallest box), and the resulting halation.

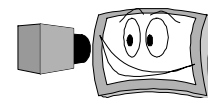
**COMMENTS:** Be careful in making the black measurement. Avoid glare corruption of black by using a black-gloss cone mask. See Veiling-Glare and Lens-Flare Errors (A101) for details on measurements of black in the presence of white.

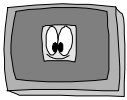
Analysis — Sample Data	
White ( $L_w$ )	95.7
Box % Diag.	$L_{box}$ cd/m <sup>2</sup>
5 % ( $L_{max}$ )	6.23
10 %	3.25
20 %	1.62
30 %	1.11
40 %	0.923
50 %	0.769
60 %	0.655
70 %	0.523
80 %	0.498
90 %	0.473
100 % ( $L_b$ )	0.468
Halation	6.0

Reporting (Sample Data)	
$L_w$	95.7
$L_b$	0.468
Min. Box	5
$L_{max}$	6.23
Halation	6.0

**WARNING**  
 This measurement can be grossly inaccurate unless proper accounting (and/or correction) is made for veiling glare or lens flare (A101-1).

OPTICAL

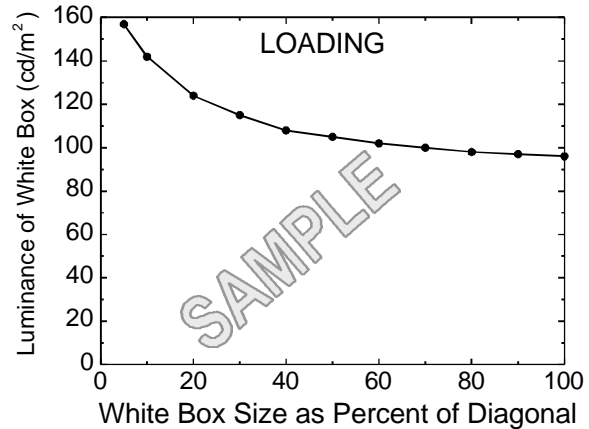
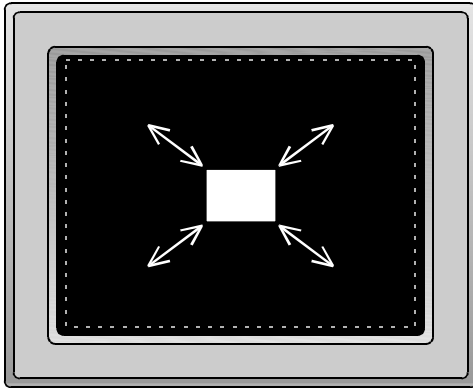




## 304-8 LUMINANCE LOADING

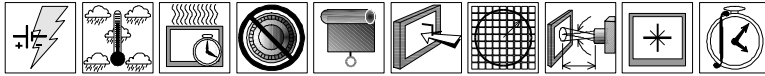
**DESCRIPTION:** We measure the luminance of a white box with a black background as the size of the box is adjusted from a small fraction of the screen to full screen.

Luminance loading is said to occur when the luminance of a white area on a screen changes as the white area changes its size. In some cases this can be a desirable effect, in other cases it can be objectionable. This method is a way to characterize the effect luminance loading.



**SETUP:** Arrange for a box to vary in size from 5 % of the screen diagonal to the full screen. See Section 301 for any standard setup details.

**SPECIFIC:** Centered white box of varying sizes on a black background.



**PROCEDURE:** Use a white box on a black background. Start with full-screen white and go down to 0.05Hx0.05V as with halation (previous measurement, 304-7). Plot the results.

**ANALYSIS:** Calculate the ratio of the difference in percent of the extreme value from the full-screen white  $L_{ext}$  and full-screen white  $L_w$ . The loading is  $100\% (L_{ext} - L_w)/L_w$ .

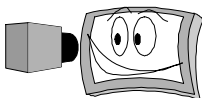
**REPORTING:** Report the full-screen white, the minimum box size used, the maximum box luminance (usually the smallest box), and the resulting loading.

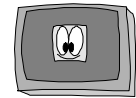
**COMMENTS:** It is advisable to use a black-gloss cone mask for all measurements since there can be a small error in the LMD where the measured luminance is slightly dependent upon the size of the area to which the lens is exposed. See Veiling-Glare and Lens-Flare Errors (A101) for details on measurements of a white region of changing size.

Analysis – Sample Data	
Box % Diag.	$L_{box}$ cd/m <sup>2</sup>
5 % ( $L_{ext}$ )	157
10 %	142
20 %	124
30 %	115
40 %	108
50 %	105
60 %	102
70 %	100
80 %	98.1
90 %	97.3
100 % ( $L_w$ )	96.2
Loading	63

Reporting (Sample Data)	
$L_w$	96.2
Min. Box	5
$L_{ext}$	157
Loading	63

OPTICAL





### 304-9 CHECKERBOARD LUMINANCE & CONTRAST (n × m)

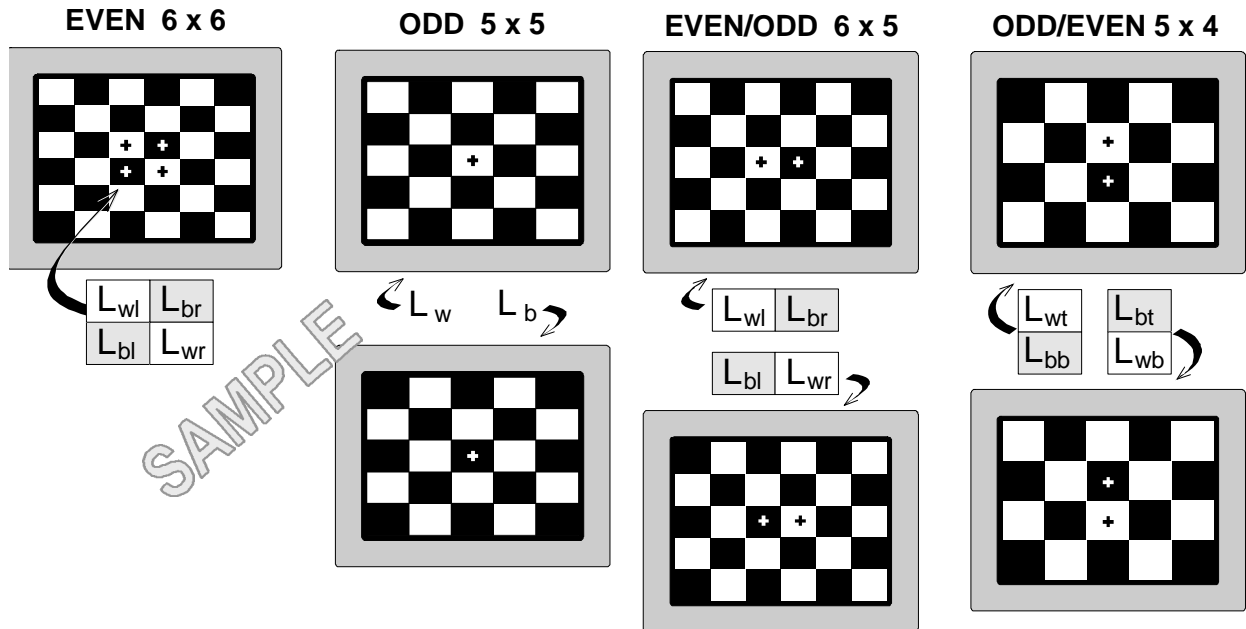


**DESCRIPTION:** We measure the black and white luminances at the vicinity of the center of a checkerboard pattern and calculate the contrast.

The specification  $n \times m$  is the number of columns ( $n$ ) by the number of rows ( $m$ ). There are several types of checkerboards. One has even rows and columns in each dimension. Another has odd rows and columns in each dimension. Most will use either the even or odd patterns. There are two types that mix even and odd that will probably be rarely, if ever, used. The only type of checkerboard what will be measured using only one pattern is the even checkerboard. All the other types (containing an odd component) require two with one being the negative of the other. In the figure we show some examples for illustration. The contrast ratio is  $C_C = L_w/L_b$ , where  $L_w$  and  $L_b$  are either the center measurements in the case of the odd checkerboard or averages of white and black boxes about the center in all other cases:

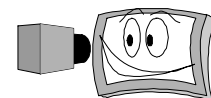
$$\text{ODD: } C_C = \frac{L_w}{L_b}, \quad \text{EVEN \& EVEN/ODD: } C_C = \frac{L_{wl} + L_{wr}}{L_{bl} + L_{br}}, \quad \text{ODD/EVEN: } C_C = \frac{L_{wt} + L_{wb}}{L_{bt} + L_{bb}}. \quad (1)$$

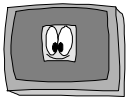
Here, the first letter in the subscript refers to black or white, and the second letter in the subscript is “l” for left, “r” for right, “t” for top, and “b” for bottom. See the figure.



OPTICAL

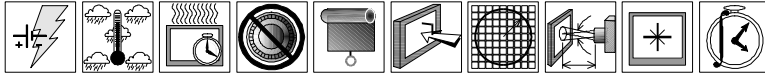
Summary of Checkerboard Formats					
Checkerboard Pattern		Required Patterns	White	Black	Contrast
Columns	Rows		$L_w$	$L_b$	$C_C = L_w/L_b$
Even	Even	1	$L_{wl} + L_{wr}$	$L_{bl} + L_{br}$	$C_C = \frac{L_{wl} + L_{wr}}{L_{bl} + L_{br}}$
Odd	Odd	2	$L_w$	$L_b$	$C_C = \frac{L_w}{L_b}$
Even	Odd	2	$L_{wl} + L_{wr}$	$L_{bl} + L_{br}$	$C_C = \frac{L_{wl} + L_{wr}}{L_{bl} + L_{br}}$
Odd	Even	2	$L_{wt} + L_{wb}$	$L_{bt} + L_{bb}$	$C_C = \frac{L_{wt} + L_{wb}}{L_{bt} + L_{bb}}$





**SETUP:** Arrange to measure the black and white luminances at the center of the boxes at or in the vicinity of the center of a checkerboard pattern. If either the number of columns or the number of rows is odd, then the negative of the pattern must also be measured. See Section 301 for any standard setup details.

**SPECIFIC:** Checkerboard pattern (also its negative if either the number of columns or rows is odd).



**PROCEDURE:** Display the desired checkerboard pattern. The luminances are measured at the center of the boxes ( $\pm 3\%$  of the screen diagonal) nearest the center of the screen according to the scheme shown in the figure (the “+” signs indicate the measurement positions). For **even** checkerboards measure the luminance at the center of the four boxes positioned next to the center of the DUT. For **odd** checkerboards measure at the center of the screen for each of the two (negative and positive) patterns obtaining the black and white luminance directly. For **even/odd** checkerboards measure the luminance of black and white on each side of the center of the screen for both the negative and positive patterns. For **odd/even** checkerboards measure the luminance of black and white above and below the center of the screen for both the negative and positive patterns.

**ANALYSIS:** See Table 1 for an outline of the procedure. For **even**, **even/odd**, and **odd/even** checkerboards, using the appropriate formula in Eq. 1, obtain the average of the black and white recorded luminances then calculate the contrast. For **odd** checkerboards calculate the contrast from the black and white luminances from the two patterns.

**REPORTING:** Report the  $n \times m$  checkerboard used, the black luminance, the white luminance, and the checkerboard contrast to no more than three significant figures. Use the average luminance values when reporting the black and white luminances for the even, even/odd, or odd/even checkerboards.

**COMMENTS:** Be careful in making the black measurement. Avoid glare corruption of black by using a black-gloss cone mask. See Veiling-Glare and Lens-Flare Errors (A101) for details on measurements of black in the presence of white.

**Note: (1)** The obvious limit to the checkerboard is the alternating-pixel checkerboard (301-3h) where each pixel is either dark or light in the checkerboard pattern. This also may be employed. However, distinguishing between even or odd is unimportant. A sampling of the dark and light pixels in the center area would be more reasonable. Small area measurements techniques must be used (A101-2). **(2)** There may be instances where a white and black checkerboard is not as useful as a checkerboard composed of two different gray levels (or even colors). There can be no objection to such modifications provided all interested parties are agreeable, and the modification is clearly documented in any report.

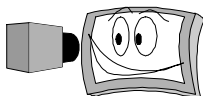
Analysis – Sample Data Even Checkerboard			
Checkerboard	6 x 6		
$L_{wl}$	101	$L_{bl}$	0.451
$L_{wr}$	105	$L_{br}$	0.477
$L_w$	103	$L_b$	0.464
$C_c$	245		

Reporting (Sample Data)	
Checkerboard	5 x 5
$L_w$	103
$L_b$	0.464
$C_c$	245

Analysis – Sample Data Odd Checkerboard	
Checkerboard	5 x 5
$L_w$	103
$L_b$	0.464
$C_c$	245

**NOTE:** The full-screen contrast ratio is the contrast metric that is always assumed unless specified otherwise for direct-view display technologies (not necessarily projection systems or any display that places a lens between the pixel surface and the viewed image—head-mount, head-up, etc.). Any other contrast metric must be properly identified explicitly if it is not this full-screen contrast ratio. We strongly suggest the above  $C_R$  in any characterization of direct-view displays. If a non-perpendicular viewing angle is used it must be reported with the contrast value.

**WARNING:** When making measurements using the (optional) positive pattern, the black measurement can be grossly inaccurate unless proper accounting (and/or correction) is made for veiling glare or lens flare (A101-1).

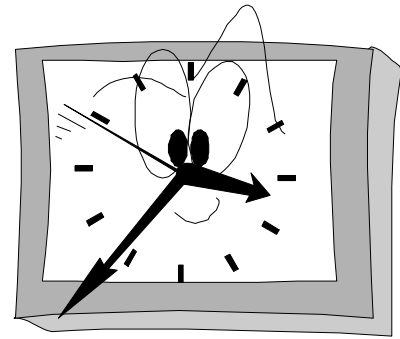




## 305 TEMPORAL PERFORMANCE

This section covers the measurement of phenomena for which the time dependence is desired. The detector required to measure the response time or transition time of any phenomena should have a response of better than 1/10 the fastest part of the phenomena under measurement. Our present offering is as follows:

- \* 305-1 RESPONSE TIME
- 305-2 RESIDUAL IMAGE
- 305-3 WARM-UP-TIME MEASUREMENT
- 305-4 DOMINANT FLICKER COMPONENT
- 305-5 FILTERED FLICKER



\* Part of the Suite of Basic Measurements (SBM).



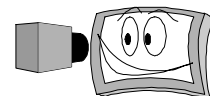
I see flicker and you don't. Now what do we do?



It says here for you to leave the room.

**NOTE:** The full-screen contrast ratio is the contrast metric that is always assumed unless specified otherwise for direct-view display technologies (not necessarily projection systems or any display that places a lens between the pixel surface and the viewed image—head-mount, head-up, etc.). Any other contrast metric must be properly identified explicitly if it is not this full-screen contrast ratio. We strongly suggest the above  $C_R$  in any characterization of direct-view displays. If a non-perpendicular viewing angle is used it must be reported with the contrast value.

**WARNING:** When making measurements of black with lighter colors on the screen (including white) the measurement can be grossly inaccurate unless proper accounting (and/or correction) is made for veiling glare or lens flare (A101).

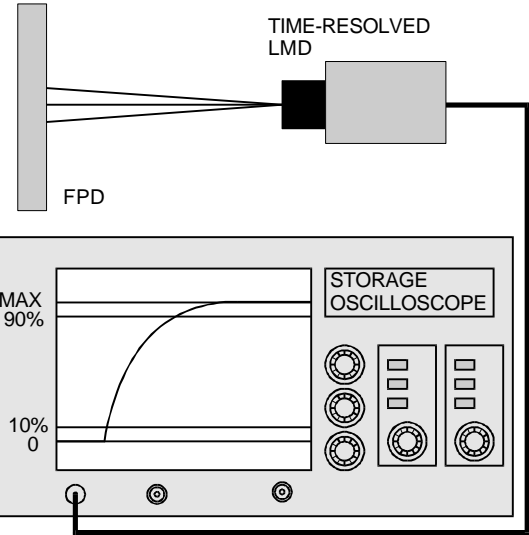




### 305-1 RESPONSE TIME

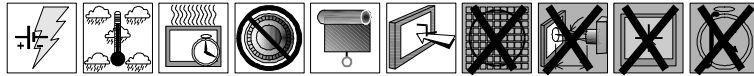


**DESCRIPTION:** The response time of a pixel is a measure of how fast the pixel can turn on and turn off. A slow response time can greatly affect the display of animation or motion video as well as the ability to follow a moving cursor. Here we measure the electro-optical step response function (SRF) resulting from pixel activation/deactivation, and report the pixel turn-on, turn-off, and image-formation times. **Units:** s, ms. **Symbols:**  $T_{on}$ ,  $T_{off}$ ,  $T_f = T_{on} + T_{off}$ , respectively.

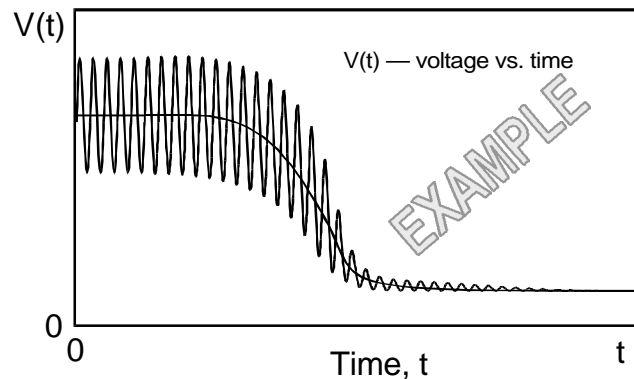


**SETUP:** The SRF is measured with an LMD capable of producing a linear response to rapid changes in luminance. The LMD response time and sample time should be less than one tenth the minimum transition time:  $T_{LMD} < 0.1 \cdot \min(T_{on}, T_{off})$ . The LMD need not be dark field corrected, and does not require photopic correction unless the color of the test pattern changes between  $L_w$  (full white) and  $L_b$  (full black). LMD samples as a function of time are typically collected, stored, processed, and displayed by a storage device such as a computer or storage oscilloscope. See section A106 (Detector Linearity Diagnostic) and section A110 (Temporal Response Diagnostics) for more information. The required pattern is discussed in the Procedure section below. See Section 301 for any standard setup details.

**SPECIFIC:** As discussed above.



**PROCEDURE:** Change the test pattern from the off state to the on state, and measure the resulting positive SRF (PSRF). The PSRF curve should include steady state on ( $L_{100}$ ) and off ( $L_0$ ) reference levels representing  $L_w$  and  $L_b$ . Change the test pattern from the on state to the off state, and measure the resulting negative SRF (NSRF).



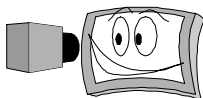
Frame refresh, backlight modulation or other sources may superimpose a periodic ripple on top of the SRF curve. If this ripple affects measurement repeatability, it may be controlled by a “tuned” moving window average filter (assuming a digitized output of the LMD): Let the ripple period be  $t$ , the LMD sample rate be  $s$ , the raw time-dependent light measurements taken at intervals of  $1/s$  be  $L_i$ , and  $\Delta N$  be the number of light data points collected during the ripple period  $\Delta N = t s$ , then the resultant moving-window-average-filtered signal  $S_i$  is given by

$$S_i = \frac{1}{\Delta N} \sum_{n=i}^{n=i+\Delta N-1} L_n .$$

See the appendix A218 (Digital Filtering by Moving Window Average) for more information.

The shape, position, color, intensity, and blink rate of an appropriate test pattern depends on the display technology, and should satisfy the following requirements:

1. The test pattern should alternately switch between  $L_w$  and  $L_b$  unless otherwise noted. Some technologies exhibit fast response times for white-black transitions, but much slower response for gray-scale transitions. If a white-black (on-off) transition is not used, it must be clearly specified to all interested parties.

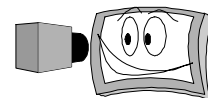
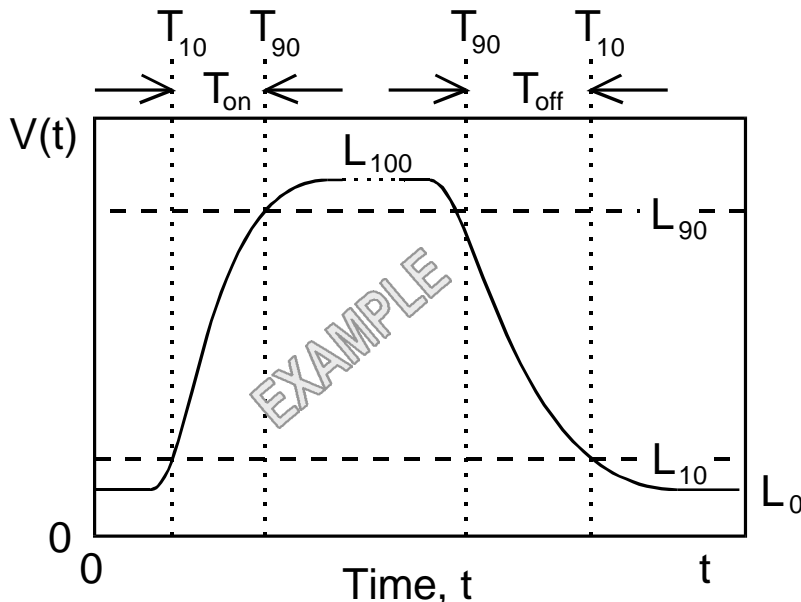




2. The test pattern blink rate should be slow enough to ensure that both the leading and trailing edges of the recorded PSRF/NSRF waveform are flat, so that  $L_{100}$  and  $L_0$  can be accurately determined. If this requirement cannot be met,  $L_{100}$  and  $L_0$  may be measured separately as long as they do not drift significantly during the SRF measurements.

In the event that the luminance asymptotically approaches the steady state value and, therefore, does not lend itself to a reasonable measurement of these response times, it is permissible to use a level line that is 5 % away from the steady-state level line as the 0 % or 100 % level line. Use as a criterion for implementing a 5 % shift as follows: if the 10 % to 90 % response time is more than three times 20 % to 80 % response time, then the 5 % shifted level reference line may be used. Alternatively, the 20 % to 80 % response time may be employed as a replacement for the 10 % to 90 % response time. Such a usage must be noted in any reporting document.

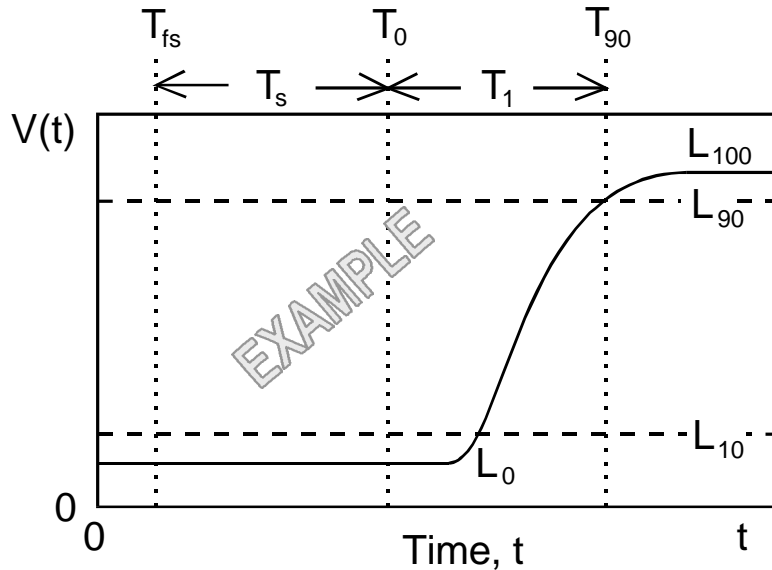
3. The test pattern may be smaller than the detector image area if the filtered luminance contribution of the background (detector image area not covered by the test pattern) is constant. Non-constant backgrounds may alternatively be removed using image-processing techniques (not covered in this document—“an exercise for the student”).
4. In general, the test pattern should be as small as possible, since we are (ideally) measuring the response of a single pixel. As a practical matter, LMDs often produce larger signal to noise ratios and more repeatable measurements when larger targets are used. Larger targets may be used if the following two requirements (5 and 6) are met:
5. When multi-pixel test patterns are generated and displayed in a raster based display system, it is possible for the test pattern update to be occasionally split across two or more display refresh cycles. When this problem can not be eliminated (by techniques such as frame-synchronous palette switching), it should be reduced as much as practical (typically, by using targets with a small number of rows). Anomalous large measurements of  $T_f$  caused by test pattern splitting should be discarded.
6. Even within a single display refresh cycle, some time is typically required to electrically address/command the pixels in the test pattern from the on state to the off state. The Test Pattern Update Time ( $T_{TPU}$ ) is the time between the first and last pixel updates in the selected test pattern. The size, shape and position of the test pattern should be selected so that  $T_{TPU} < 0.1T_f$ . Note that for most display technologies, the largest possible value for  $T_{TPU}$  is the refresh time  $T_R$ : in this case, if  $T_R < 0.1T_f$ , the  $T_{TPU}$  requirement is met. Note also that the test pattern should not span the seam on dual-scanned displays or tiled displays, since this will cause  $T_{TPU}$  to equal  $T_f$ . Since  $T_{TPU}$  can be difficult to calculate or measure, the following diagnostic may be used instead of an actual  $T_{TPU}$  measurement/calculation: Measure  $T_f$  twice, once using the intended test pattern, and the second time using a very small test pattern (a single pixel if possible). If the two measurements agree within 5 %, then the  $T_{TPU}$  requirement is met.





**ANALYSIS:** Apply ripple filters as necessary. Calculate  $L_{\text{range}} = L_{100} - L_0$ ,  $L_{10} = 0.1L_{\text{range}} + L_0$  and  $L_{90} = 0.9L_{\text{range}} + L_0$ . Find the times  $T_{10}$ ,  $T_{140}$  at which the PSRF equals  $L_{10}$ ,  $L_{90}$  (using linear interpolation between the bounding data points) and record  $T_{\text{on}} = T_{90} - T_{10}$ . In a similar way, measure the NSRF and record  $T_{\text{off}} = T_{10} - T_{90}$ .

**REPORTING:** Report the test pattern used (position, size, color, and blink on/off times), the LMD sample rate, the filtering used (if any),  $T_{\text{on}}$ ,  $T_{\text{off}}$ , and  $T_f$ . Optionally, the raw and filtered SRF curves may be included with the reporting sheet. If multiple independent measurements are made, report the mean of the resulting values.



**COMMENTS:**  $T_{\text{on}}$  and  $T_{\text{off}}$  only measure the optical SRF curve: any delay between the electrical activation of a pixel and the start of the pixel's optical SRF is not measured. The alternate measurement method described here measures the two additional values  $T_1 = \text{PSRF time from electrical activation to } T_{90}$ , and  $T_2 = \text{NSRF time from electrical deactivation to } T_{10}$ . This measurement procedure is intended to be identical to the procedure in section 5.2 of EIAJ ED-2522. Note that this procedure requires access to DUT electrical signals and timing information.

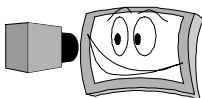
The electrical activation/deactivation time ( $T_0$ ) is the time when the centermost pixel of the test pattern is addressed by the DUT hardware. Since this time is difficult to measure directly, it is normally calculated as  $T_0 = T_{\text{fs}} + T_s$ , where  $T_{\text{fs}}$  is an electrical start of frame synchronization signal (typically acquired from the DUT signal connector), and  $T_s$  is the scanning time from  $T_{\text{fs}}$  to centermost pixel of the test pattern. (Typically calculated from the DUT timing diagrams).



Your specs say a backlight of 300000 hours...?! What life metric did you use?



Um... we measured it at one hour and then again at two hours and extrapolated to zero luminance.





## 305-2 RESIDUAL IMAGE

(latent image, burn-in, image retention)



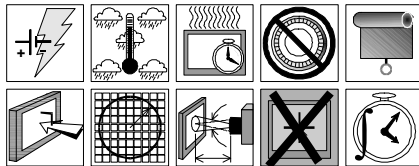
**NOTE:** This measurement can cause irreparable damage to the display.

**DESCRIPTION:** Measure the residual image of a high-contrast checkerboard. **Units:** in percent of full-screen white. **Symbol:**  $R_W$  for white,  $R_B$  for black.

This is a measurement of how the screen is affected by long-term static images. We will see how a long-term static  $5 \times 5$  checkerboard affects the display of a full-white screen and a full-black screen. Initially, we will measure the full screens of both white and black at three locations to account for any local luminance nonuniformities. Then we burn in the checkerboard. Finally examine full screen white and black to see if there is any residual image.

**SETUP:** Arrange to measure the display at three points left of center a distance of the checkerboard box width, at center, and right of center a distance of a box width. Depending upon how uniform the screen is, it may be necessary to measure at the exact same three locations throughout the procedure. This will require a reproducible positioning of the LMD relative to the screen. You will need to display a white full screen, a black full screen, and a  $5 \times 5$  checkerboard pattern of black and white boxes with a black box at the center and box size of  $1/5$  of the screen.

**SPECIFIC:** Full-screen white, full screen black, and  $5 \times 5$  checkerboard patterns.



### PROCEDURE:

#### Initial Measurements:

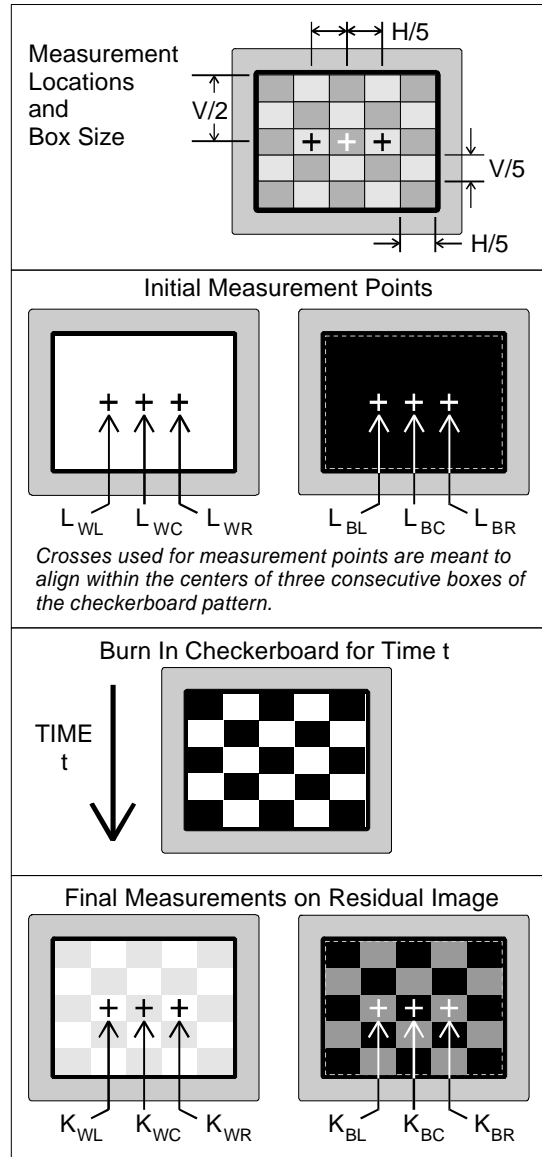
Display a white full screen and measure the center luminance  $L_{WC}$  and the luminance on each side of center  $L_{WR}$  and  $L_{WL}$  (for right and left) a distance of  $20\%$  ( $H/5$ ) of the screen horizontal width  $H$ . Similarly, display a full black screen and measure the luminances  $L_{BC}$ ,  $L_{BR}$ ,  $L_{BL}$  at the same three locations.



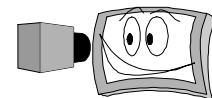
**Burn-in:** Burn-in the checkerboard image by allowing it to remain displayed continuously for the a certain number of hours  $t$  agreed to by all interested parties (the number of hours  $t$  is reported). Near the end of the burn-in time align the LMD to measure at the same three locations.

**Final Measurements:** At the end of the burn in time, switch the DUT directly from a checkerboard to a white full screen, after a time interval upon which all interested parties agree  $t_R$  (or as soon as possible) measure the luminance at the three locations (center, right, left)  $K_{WC}$ ,  $K_{WR}$ ,  $K_{WL}$ . Then switch the display to a black full screen, and measure the luminances at the three locations (center, right, left)  $K_{BC}$ ,  $K_{BR}$ ,  $K_{BL}$ . These measurements should be made in as small a time as is easily possible.

**ANALYSIS:** In what follows, we will be using ratios of these luminance values. By using ratios, we eliminate the effects of overall luminance degradation of the display from either an extended warm-up period or from aging.



OPTICAL





We also need to account for any nonuniformity inherent in the screen for the three measurement points. From the initial measurements determine the uniformity correction factors for white and black screens from the initial luminance measurements ( $L_{WC}, L_{WR}, L_{WL}, L_{BC}, L_{BR}, L_{BL}$ ):

$$\text{Nonuniformity Corrections: } U_W = \frac{L_{WR} + L_{WL}}{2L_{WC}}, \quad U_B = \frac{L_{BR} + L_{BL}}{2L_{BC}}. \quad (1)$$

The residual image factors are then obtained from the final luminance measurements ( $K_{WC}, K_{WR}, K_{WL}, K_{BC}, K_{BR}, K_{BL}$ ):

$$\text{Residual Image Factors: } R_W = 1 - U_W \frac{2K_{WC}}{K_{WR} + K_{WL}}, \quad R_B = U_B \frac{[(K_{BR} + K_{BL}) / 2] - K_{BC}}{\max(K_{WC}, K_{WR}, K_{WL})}. \quad (2)$$

$R_W$  is the fractional amount that the white center has changed relative to the adjacent sides corrected by the white nonuniformity factor.  $R_B$  is the fractional amount that the black center has changed relative to the adjacent sides corrected by the black nonuniformity factor compared to the maximum luminance of the white screen at the three locations. Negative values for  $R_W$  or  $R_B$  indicate reversals from the checkerboard pattern.

**REPORTING:** Report the burn-in time  $t$  in hours (the agreed upon time interval, in the examples we show 5 hours as an illustration only), the measurement time after burn-in ( $t_R$ ), and the measured residual image of white  $R_W$  and black  $R_B$  in percent of white full screen to no finer precision than 0.1 %.

**COMMENTS:** This measurement does not account for sensitivity of residual images from colors or gray-scales. Be sure to use a small enough measurement aperture to be completely contained within a checkerboard measurement box area. It is suggested that at least 20 % of the measured area should extend past the measurement aperture area on all sides. The luminances for the white and black screens at the center and on each side of the center must be measured in the same time frame (within a few minutes). It cannot be measured before the end of the Burn-in period. The residual image factors may not be uniform over the entire display area. Areas with the most pronounced amount of residual image should be assessed. If it appears to generally be uniform, then measuring at the center of the screen and the adjacent boxes is preferred. **Note:** If deemed appropriate by all interested parties and provided any modifications are clearly stated in all reporting documentation (1) Other patterns may be used. (2) This measurement can be extended to be used with points other than at the center of the screen.

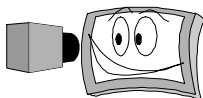
Reporting (Sample Data)	
Residual Image	
Burn-in, $t$	5 h
$R_W$	17.8
$R_B$	5.4
$t_R$	A AP

Analysis (Sample Data)	
Quantity	Value
$L_{WC}$	94.6
$L_{WR}$	92.1
$L_{WL}$	93.5
$L_{BC}$	0.502
$L_{BR}$	0.453
$L_{BL}$	0.487
$U_W$	0.981
$U_B$	0.936
$t$	5 h
$t_R$	A AP
$K_{WC}$	70.0
$K_{WR}$	85.2
$K_{WL}$	82.9
$K_{BC}$	0.736
$K_{BR}$	5.422
$K_{BL}$	5.218
$R_W$	17.8
$R_B$	5.4

**RECOVERY:** There is no set way to recover from a residual image. Recovery procedures range from maintaining a full-screen white for a long period of time, displaying a changing series of images, to displaying the negative image of the image that originally produce the residual image. The manufacturer should be contacted for any possible recovery technique.

**NOTE:** Don't be fooled by the values of these measurements. A 5 % change in white luminance is hard to see, but if you add 5 % of the white luminance to the luminance of a black box, it will be very noticeable. To get a better idea of what your eye sees, calculate the CIE  $L^*$  values (see A201, Photometry and Colorimetry Summary) and use these instead of the luminances in the above equations as a comparison.

For example, a 5 % decrease in white from a burn in would, using  $L^*$  instead of luminance, give an observable residual image of  $R'_W = 1.7$  %. However, take that same 5 % of white and add it to the center black box and the observable residual image is much more obvious,  $R'_B = 36.8$  %. This says that the noticeability of the 5 % white added to the black is much greater than the noticeability of the 5 % drop in white—as we would expect. In our sample data above the white value of  $R_W = 17.8$  % would become  $R'_W = 6.3$  % if we used  $L^*$  values instead of luminance values. So it would still be relatively small compared to the visibility of a 5 % luminance modification of black. If the white value was  $R_W = 75$  % [ $2L_{WC}/(L_{WR} + L_{WL}) = 0.252$ ] then to the eye,  $R'_W = 36.8$  %, and only then would it appear as noticeable as a 5 % luminance modification of black. The discrepancy between the linear luminance values and the visually observable values comes from the cube-root factor in the  $L^*$  determination that attempts to model the response of the eye.



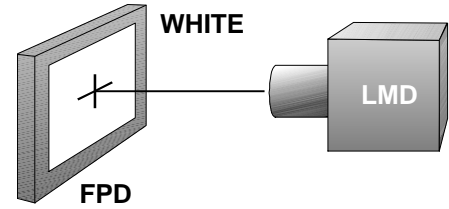


## 305-3 WARM-UP-TIME MEASUREMENT

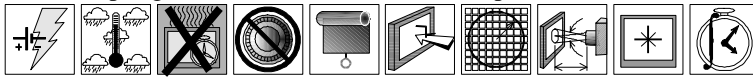
(time to reach luminance stability)

**DESCRIPTION:** Measure the time required to reach stable luminance output assessed by a luminance instability of  $\pm 5\%$  per hour of operation or less using a white full-screen center measurement of the luminance.

Before making measurements on the DUT, it is important that it has had sufficient time to reach operating stability. If this is not done, changes in performance might be attributed to some deficiency of the display and not because the warm-up was inadequate. This is a verification test if there is concern over, need to change, or desire to measure the warm-up time. The 20-min standard warm-up time should be used unless there is a technical reason for doing otherwise. If the DUT is turned on prior to this measurement, we recommend that you let the display equilibrate to the ambient temperature for a period of 3 h or longer. A shorter cool-down time can be used if it has been established as being adequate for the DUT. (Adequacy is established by turning on the display and measuring  $L(t)$  as described below. Then let the display cool for 3 h whereby the display is turned on and  $L(t)$  is re-measured. Let the display cool for 2 h and then turn it on and re-measure  $L(t)$ . Repeat this process for as many shorter times you wish. If for any cool-down time period shorter than 3 h the luminance as a function of time is within 2 % of the entire luminance-versus-time curve obtained for the three-hour period, then the shorter period may be used.)



**SETUP:** *Do not warm up the DUT prior to making these measurements!* Arrange to display a white full screen and arrange to measure the center luminance of the screen as soon as the screen displays the white full-screen image. If the display had been on previously, wait three hours or longer with the display turned off before attempting a measurement of the warm-up time. See Section 301 for any standard setup details.



**PROCEDURE & ANALYSIS:** When the DUT is turned on record the time as  $t_0$ . Measure  $L_1$  at  $t_1$  as soon as you can after a full white screen is displayed. Continue to measure the luminance  $L_i$  at time intervals of ten minutes or less (there is no objection to measuring as often as you wish and the intervals don't have to be the same); the time of the beginning of the measurement is  $t_i$ . Try to record all times to an uncertainty of 10 s or less. As the luminance levels off to its stable value, look for the shortest time  $t_s$  where all the luminance values fall within  $\pm 5\%$  of the final value for a duration  $\Delta t$  of one hour.

Mathematically,  $t_s$  is the shortest time for which  $L - \delta L \leq L_i \leq L + \delta L$  for all  $L_i$  within the time interval  $t_s$  to  $t_s + \Delta t$ , where  $L$  is the final value of  $L_i$  at the end of the same interval  $t_i$  to  $t_s + \Delta t$  and  $\delta L = 0.05L$  (5 % of the average).

**REPORTING:** Report the warm-up time in minutes to no more than two significant figures. If the warm-up time is measured to be less than 2 min, it is permissible to report the warm-up time in seconds.

**COMMENTS:** Generally, the default 20-min warm-up time is adequate and will

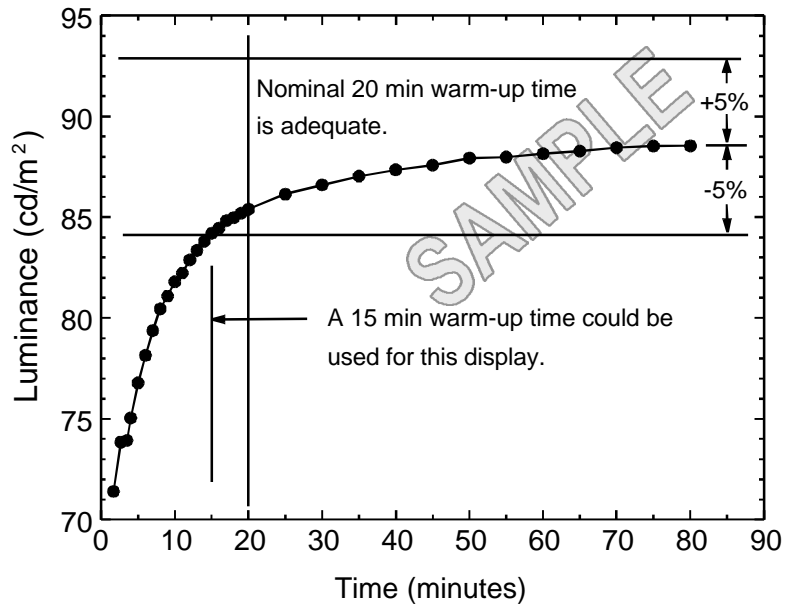
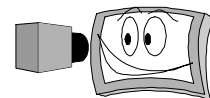


Fig. 1. Warm-up time measurement of an AMLCD

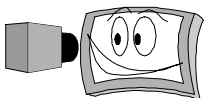
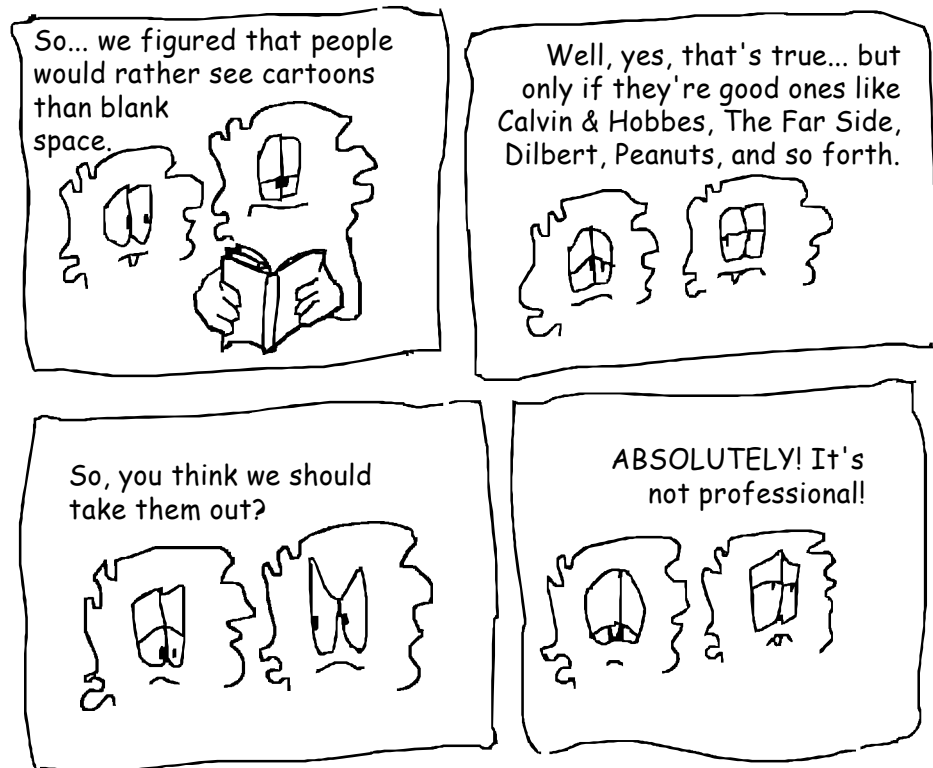
OPTICAL





rarely have to be validated. However, there may be situations which require a warm-up time measurement: The recommended 20-minute warm-up period is an estimated adequate time for most displays, the tester may wish to more precisely determine the warm up time needed for a specific display technology. Conversely, it may be required to use a longer warm-up time to assure luminance stability. Once an adequate warm up time has been established by the above method, it may be considered to be the normal warm up time (instead of the default 20 min) for the technology and conditions under which it was determined, if desired.

In reality, absolute luminance stability can never be achieved since there are long-term stability and life issues associated with displays. Luminance will decay over the lifetime of the display, since it requires energy transfer, which will have efficiency losses. For example, if the lifetime is rated at 10,000 hours for a 100 cd/m<sup>2</sup> display, and the display degrades linearly to zero light (which it does not do), the luminance is degrading at the rate of 0.010 cd/m<sup>2</sup>/h or 0.01 % per hour. In some cases, luminance may actually increase in time for some life of the display before the life degrading cycle begins. Small luminance changes over long periods such as these are ignored for warm up. Don't forget about the stability of the luminance measurement with refreshed displays or ac-fluorescent backlights because of a finite integration time of the LMD (see A102, Spatial Invariance and Integration Times, for more details on finite integration times and diagnoses).





## 305-4 DOMINANT FLICKER COMPONENT

(EIAJ flicker level, ISO flicker)

**DESCRIPTION:** We measure intensity as a function of time, then use Fourier analysis to compute flicker intensity as a function of frequency, and finally calculate flicker levels and report the frequency and flicker level of the highest flicker peak. **Units:** Hz, dB

On some display technologies, certain viewing angles, test patterns, colors, and/or drive levels may cause the display to appear to flicker, even though a constant test pattern is displayed. See section 301-3f (Flicker Visibility Assessment) for a discussion of flicker, and for a subjective flicker test that may be performed during warm-up.

**SETUP:** The nominal test pattern is constant full screen white at maximum drive ( $L_w$ ). If other empirically or analytically derived worst-case test patterns are used, the changed color, drive level, pattern, and/or viewing angle should be listed in the report.

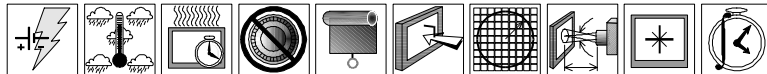
On some displays, gray scale is displayed using multiple refresh frames. Use the DUT design documentation to calculate  $F_{\text{repetition}}$  (normally the frame refresh rate divided by some integer), which is the gray scale image repetition frequency.  $F_{\text{repetition}}$  may also be derived from manual or automatic inspection of the intensity waveform.

Intensity as a function of time may be measured with the same LMD used in 305-1 “Response Time”, with the following additional requirements (other apparatus may be used if the same results are obtained):

1. The LMD must be dark field (zero) corrected.
2. The LMD must be photopically corrected unless it is known that there is no color shift as a result of flicker.
3. The LMD output should be low-pass filtered, with band pass of 0 to 150Hz( $\pm 3\text{db}$ ), and -60db at the sample frequency. This filtering can be done in the LMD itself, or by filtering oversampled data using a digital filter such as the moving-window-average filter.

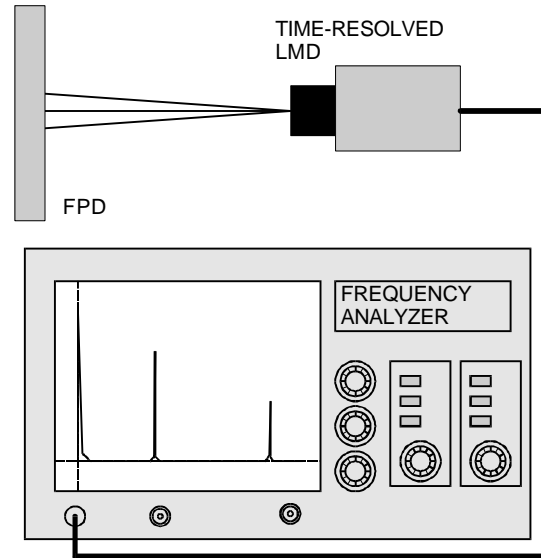
Intensity as a function of frequency is computed by Fourier analysis. The measurement procedure below assumes the use of a fast Fourier transform (FFT) on a digital computer. Other analysis procedures may be used if the same results are obtained. The sample frequency  $F_{\text{sample}}$  should be adjusted so that  $N_{\text{samples}} = F_{\text{sample}} / F_{\text{repetition}}$  is at least 64, and a power of two (64, 128, 256, ...). If  $F_{\text{sample}}$  cannot be adjusted, the intensity data should be digitally re-sampled to achieve the same effect. This sample rate restriction helps to calculate accurate flicker peaks by insuring that the sub-harmonics of  $F_{\text{repetition}}$  are not split between two FFT frequency range “buckets”. Other techniques may also be used as long as the same results are obtained. See section 301 for any standard setup details.

**SPECIFIC:** Described above.

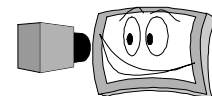


**PROCEDURE:**

1. Display the selected test pattern, and wait until the test pattern is stable.
2. Collect the array  $f_{\text{raw}}[0 \dots N_{\text{samples}} - 1]$  intensity data samples at the sample frequency  $F_{\text{sample}}$ .
3. Calculate the FFT coefficients and the corresponding flicker levels. For each FFT frequency, the resulting coefficient is weighted by (multiplied by) the corresponding scaling factor in the table below. This weighting is performed to adjust the measured flicker levels to match the approximate temporal flicker sensitivity of the human eye, where flicker sensitivity decreases as the flicker frequency increases.



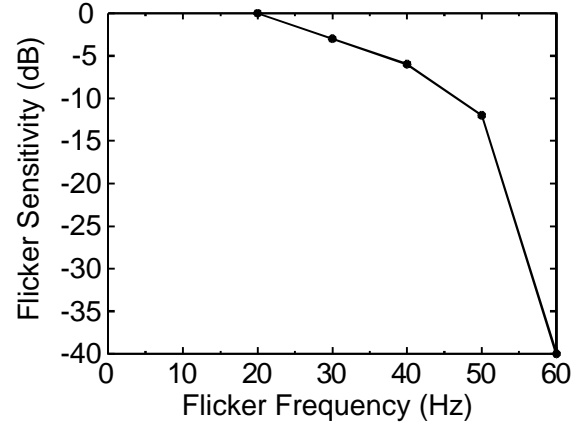
OPTICAL





**Table 1. Flicker Weighting Factors**  
Use linear interpolation between the listed frequencies.  
“Scaling: dB” is equivalent to “Scaling: Factor”

Frequency: Hz	Scaling: dB	Scaling: Factor
20	0	1.00
30	-3	0.708
40	-6	0.501
50	-12	0.251
>= 60	-40	0.010



**ANALYSIS:**

1. Validate the FFT algorithm as per the FFT validation section in the comments below.
2. Use  $f_{raw}[ ]$  to calculate  $f_{fttc}[0 \dots (N_{samples}/2) - 1]$ , the array of FFT coefficients, each representing the flicker intensity for a certain frequency range. Note that the center frequency of  $f_{fttc}[n] = nF_{sample}/N_{samples}$ . Also note that  $f_{fttc}[0]$  is the DC, or average, intensity.
3. Scale the  $f_{fttc}[ ]$  array by the human visual sensitivity factors in the Table 1, using linear interpolation between the listed values, yielding the scaled FFT coefficient array  $f_{sfttc}[ ]$ .
4. For each element in  $f_{sfttc}[ ]$ , calculate the flicker level =  $20\log_{10}(2f_{sfttc}[n]/f_{sfttc}[0])$  dB. (This is the equation for calculating dB directly from the validated FFT coefficients. If the flicker level is to be calculated from "power spectrum" FFT coefficients, where each coefficient has been squared, EITHER take the square root of each coefficient to yield the validated form, OR use the alternate equation flicker level =  $10\log_{10}(\text{power}[n]/\text{power}[0])$  dB.) Here, we are calculating the weighted flicker level at each frequency in decibels with respect to the mean luminance.

**REPORTING:** Report any variations from standard setup/test pattern,  $F_{repetition}$ ,  $F_{sample}$ , and the frequency and value of the largest flicker level. Optionally, report all flicker levels.

**COMMENTS:** This measurement is intended to be consistent with section 5.13, “Flicker”, in EIAJ ED-2522. If the LMD is photopically corrected and calibrated, the FFT coefficient array  $f_{fttc}[ ]$  is identical to the array  $FFT(v)$  in section B.2.2 “Fourier Coefficients” in ISO 13406-2 Annex B. Please note that the flicker weighting factors shown are from the EIAJ document. Other weighting factors may be used, as long as all interested parties agree and the alternate factors are clearly reported in all documentation. **Warning:** Display flicker can cause discomfort in varying degrees depending on the individual, and can precipitate epileptic seizures in susceptible individuals [see P. Wolf and R. Goosses, Relation of photosensitivity to epileptic syndromes, J. Neurol., Neurosurg., and Psychiat. 49, 1386-1391 (1986)]. The problem tends to be worse for frequencies near 10 Hz, for greater modulation depths, for greater angular subtense of the flicker, and for redder light. If any display has a substantial flicker component near 10 Hz, this is cause for concern.

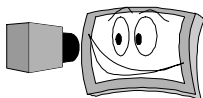
The FFT algorithm should return un-normalized results, with the average of the sampled values as the first term. The FFT algorithm can be validated using the following procedure:

1. Set  $N_{samples}=64$ ;  $f_{raw}[0 \dots 47] = 100$ ;  $f_{raw}[48 \dots 63] = 0$ .
2. Perform the FFT calculation.
3. The first four resulting terms of  $f_{fttc}[ ]$  should be {75.00, 22.50, 15.94, 7.54}, or these values scaled by any constant amount. Noncompliant FFT algorithms might be corrected by replacing the first term with the average of the sampled values, or by scaling the remaining terms by a factor of two.
4. Worked Example: Use the raw data as in #1 above, and  $F_{repetition}=15$  Hz. (This might represent some hypothetical bi-level display with a 60 Hz refresh rate, using the four frame encoding (1,1,1,0) to represent 75 % full white.) The maximum flicker level for this hypothetical display is -4.4 dB at 15 Hz.

**Table 2. Sample Data**

Index	$f_{fttc}$	Freq. (Hz)	Weight	$f_{sfttc}$	Flicker Level (dB)
0	75	DC	1	75	-----
1	22.5	15	1	22.5	-4.4
2	15.94	30	0.708	11.29	-10.4
3	7.54	45	0.376	2.84	-22.4

OPTICAL





## 305-5 FLICKER MODULATION AMPLITUDE

**NOTE:** This measurement is currently under study and is presented here as a possible useful alternative to more complicated flicker measurements.

**DESCRIPTION:** We provide a simple flicker characterization—called flicker modulation amplitude (FMA)—by measuring the time-dependent amplitude modulation of the screen luminance filtered according to an empirical flicker sensitivity function based on frequency.

This is a simplified measurement of flicker phenomena that may assist in the establishment of design and acceptance criteria on the phenomena giving rise to flicker (without requiring FFT analysis). It may be useful for simple modulations of the luminance. Please note that the flicker visibility threshold data shown are from the EIAJ document (see 305-4 for more details). Other flicker visibility threshold data may be used, as long as all interested parties agree and the alternate factors are clearly reported in all documentation.

On some display technologies, certain viewing angles, test patterns, colors, and/or drive levels may cause the display to appear to flicker, even though a constant test pattern is displayed. See section 301-3f (Flicker Visibility Assessment) for a discussion of flicker, and for a subjective flicker test that may be performed during warm-up.

**SETUP: Equipment:** In order to capture the time-dependence of the luminance, an LMD that has a sufficiently fast response must be used (this is your responsibility to establish this—see A110 for temporal response diagnostics). The output of the LMD must be properly terminated at the filter (to avoid signal reflections within the connecting cable). An oscilloscope measures the output of the filter. The LMD must also not saturate at the peak of the luminance profile (check this out by removing the filter and looking at the output of the LMD directly). The filter is provided to electronically replicate the flicker visibility threshold curve used, and can be either analog (shown) or be achieved by digital processing. The filter should be tested. The LMD can be at any specified angle from the normal and measure anywhere on the screen that provides the worst case flicker.

**Test Pattern:** The nominal test pattern is a constant full screen. Empirically or analytically derived worst-case test patterns are used with the color, drive level, pattern, and/or viewing angle should be listed in the report. (See section 301-3f, Flicker Visibility Assessment, for further discussion about flicker characteristics and determining patterns to be used.) Flicker may be examined with ambient lighting, but the luminance measurements should be made in a darkroom

**SPECIFIC:** Worst-case test pattern described above. See Section 301 for any standard setup details.

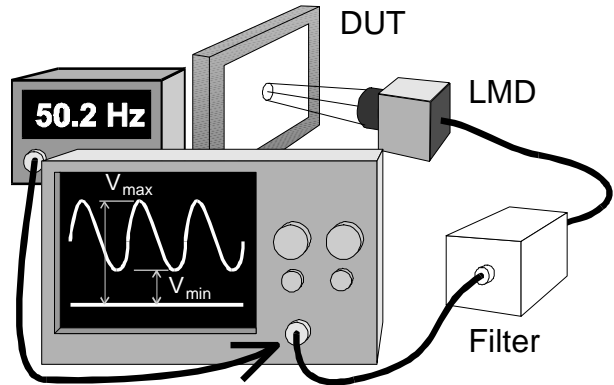
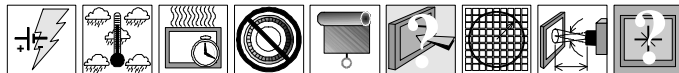


Fig. 1. Equipment with optional frequency counter.

EIAJ Flicker Sensitivity vs. Frequency		
Freq. (Hz)	Flicker Sensitivity (dB)	Scaling: Factor $F(f)$
$f$		
20	0	1.00
30	-3	0.708
40	-6	0.501
50	-12	0.251
$\geq 60$	-40	0.010

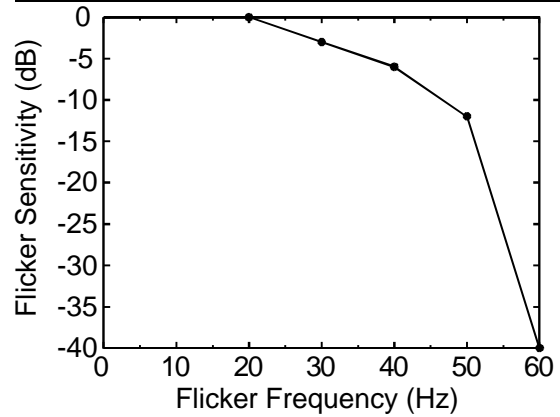
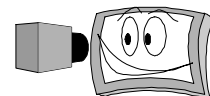


Fig. 2. EIAJ flicker sensitivity curve.

OPTICAL





**PROCEDURE & ANALYSIS:**

The analysis and procedure below assumes the filtered luminance profile  $V(t)$  and not the unfiltered luminance profile.

1. Determine the worst case flicker pattern. For example, while changing the gray levels from white to black, determine the peak-to-peak modulation of the filtered luminance  $V_{pp}$  (use ac coupling) and compare it to the approximate average dc level  $V_{dc}$  (use dc coupling). Look for the pattern that produces the largest ratio  $V_{pp}/V_{dc}$ .
2. Determine the frequency of the modulation  $f$  as the inverse of the modulation period  $T$ . A frequency counter may be used to determine this provided it is connected after the filter.
3. Measure the filtered luminance as a function of time according to the above setup conditions. Set the time base of the oscilloscope for no more than 10 ms per division. Use dc coupling.
  - a) Determine the location of the ground line (i.e., zero luminance level,  $V_0$ ) by blocking all light to the LMD, as with a lens cap.
  - b) Measure the maximum of the waveform  $V_{max}$ .
  - c) Measure the minimum of the waveform  $V_{min}$ .
  - d) Determine the percent flicker modulation amplitude (FMA) as follows.

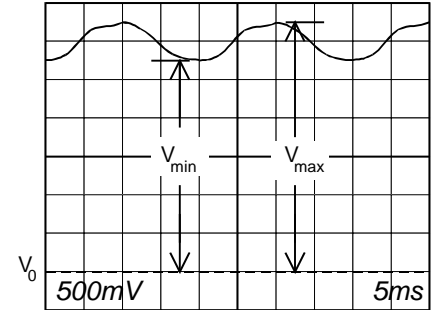
$$FMA = 100\% \frac{V_{max} - V_{min}}{V_{max}}$$

For small modulation amplitudes (less than 13 %) that are difficult to read or measure on the oscilloscope screen using dc coupling, a good approximation will be obtained by measuring the peak-to-peak luminance amplitude modulation  $V_{pp}$  using ac coupling and comparing it to the approximate dc level  $V_{dc}$  obtained from dc coupling.

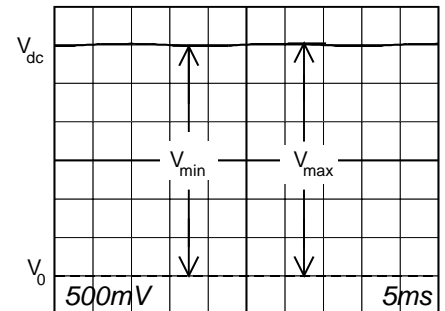
$$FMA = 100\% \frac{V_{pp}}{V_{dc}} \quad (\text{for small signals only}).$$

**REPORTING:** Report  $V_{max}$ ,  $V_{min}$ , (or for small signals  $V_{pp}$  and  $V_{dc}$ ), and the main frequency  $f$  to no more than three significant figures, and report the FMA to no more than two significant figures. Also report the pattern that was chosen. If the LMD is located at a non-perpendicular direction and does not measure the center of the screen, it should be reported.

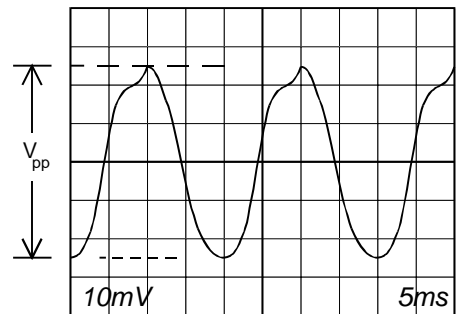
**COMMENTS:** There may be differences in the result obtained from this measurement and the FFT method (305-4), such as for flicker with numerous frequency components of relatively high magnitude or if there are low repetition rate components of the flicker. Any low repetition rate component of the flicker can be viewed as part of the results. **Warning:** Display flicker can cause discomfort in varying degrees depending on the individual, and can precipitate epileptic seizures in susceptible individuals [see P. Wolf and R. Goosses, Relation of photosensitivity to epileptic syndromes, J. Neurol., Neurosurg., and Psychiat. 49, 1386-1391 (1986)]. The problem tends to be worse for frequencies near 10 Hz, for greater modulation depths, for greater angular subtense of the flicker, and for redder light. If any display has a substantial flicker component near 10 Hz, this is cause for concern.



a)  $V_0 = \text{LMD zero reference level}$  dc coupling



b)  $V_0 = \text{LMD zero reference level}$  dc coupling

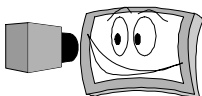


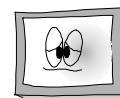
c) ac coupling

**Fig. 3.** Examples of oscilloscope traces: a) 15% FMA, b) & c) with small modulation providing 1.6% FMA

**Reporting — Sample Data**

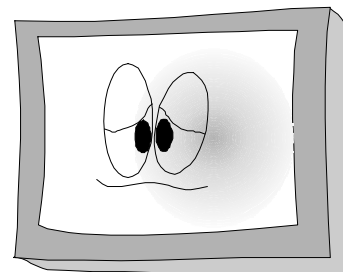
Example	Pattern	Level	# Levels	$V_{max}$ or $V_{dc}$	$V_{min}$ or $V_{pp}$	$T$ (ms)	$f$ (Hz)	FMA
Fig 3a	gray	5	16	6.5V	5.5V	20	50	15 %
Fig. 3b & c	gray	8	16	3V	0.050V	20	50	1.6 %





## 306 UNIFORMITY

Uniformity refers to a metric that characterizes the changes in luminance or color over the surface of a screen. However, just the differences are not the only thing important. The gradient of the luminance shift over the screen is also important. A screen that slowly changes in luminance 20 % over its entire surface would not readily be noticed to the eye. But if that change were to occur over a one-degree range from the viewer's perspective, it would be noticeable. We start with sampled uniformity because of its simplicity. More measurements will be added as the procedures become fully developed.



**Luminance uniformity** (or nonuniformity) is a measure of how well the luminance remains constant (or changes) over the surface of the screen. A 100 % uniformity would indicate that the luminance is perfectly uniform across the area of the screen. A 90 % uniformity would indicate that the screen suffers from a small deviation from perfection. We also speak of nonuniformity. A 10 % nonuniformity would mean the screen is almost perfect. Sometimes people mean nonuniformity when they say uniformity. For this reason we define both here. Most of the titles in this section refer to uniformity, largely because of tradition. However, the desired metric is usually the nonuniformity. Suppose we measure the luminance at several points on the screen and determine the minimum  $L_{\min}$  and maximum  $L_{\max}$  of that sample set. Uniformity and nonuniformity are defined by:

$$\text{Uniformity} = 100\% \frac{L_{\min}}{L_{\max}}, \quad (1)$$

and

$$\text{Nonuniformity} = 100\% \frac{L_{\max} - L_{\min}}{L_{\max}} = 100\% \left( 1 - \frac{L_{\min}}{L_{\max}} \right). \quad (2)$$

**Color uniformity** refers to how well the color remains constant over the surface of the screen. Conversely, nonuniformity of color characterizes how the color changes over the surface of the screen. The nonuniformity of colors is best specified by the maximum color difference (using some color difference metric) between any two points on the screen. We recommend the use of the  $\Delta u'v'$  color difference metric, where

$$\Delta u'v' = \sqrt{(u'_1 - u'_2)^2 + (v'_1 - v'_2)^2}, \quad (3)$$

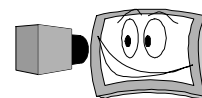
where  $(u'_1, v'_1)$  and  $(u'_2, v'_2)$  are any two colors, and the relationship between the  $(x, y)$  chromaticity coordinates and the  $(u', v')$  coordinates is

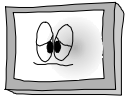
$$u' = \frac{4x}{3 + 12y - 2x}, \quad v' = \frac{9y}{3 + 12y - 2x}. \quad (4)$$

Roughly speaking, two adjacent color patches can usually be distinguished with a  $\Delta u'v' \geq 0.004$ , but for separated colors, a shift of  $\Delta u'v' \geq 0.04$  is often required to notice a color change (see A201).

**Sampled vs. Area Uniformity:** There are at least two types of uniformity: sampled uniformity and area uniformity. Sampled uniformity refers to comparing several discrete points on the screen and provides a quick check of the uniformity. Area uniformity requires the use of a scanning or array LMD to obtain a measure of the uniformity for the entire display surface. Such measurements can be difficult and require expensive equipment. For this reason, sampled uniformity is helpful.

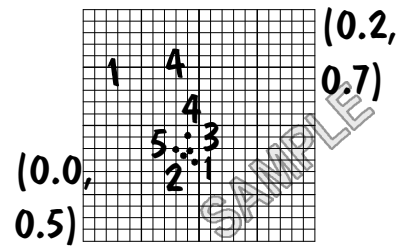
**Sampled Uniformity:** There are several ways to define sampled uniformity for **luminance**: **(1)** Determine the largest deviation from the average: If  $L_{\text{ave}} - L_{\min} > L_{\max} - L_{\text{ave}}$  then use  $\Delta L = L_{\min} - L_{\text{ave}}$  otherwise let  $\Delta L = L_{\max} - L_{\text{ave}}$  (this is the extreme value; it will preserve the sign of the greatest deviation). The nonuniformity could then be expressed by  $100\% \Delta L / L_{\text{ave}} \equiv 100\% \max |L_i - L_{\text{ave}}| / L_{\text{ave}}$ . **(2)** Base the nonuniformity on the average value  $100\% (L_{\max} - L_{\min}) / L_{\text{ave}}$ , or **(3)** the standard deviation  $100\% s_L / L_{\text{ave}}$ , where  $s_L$  is the standard deviation of the  $L_i$  for  $i = 1, 2, \dots$ . **(4)** Base the nonuniformity on the center measurement  $100\% \max |L_c - L_i| / L_c$ . **(5)** Base the nonuniformity on the deviation from the maximum  $100\% (L_{\max} - L_{\min}) / L_{\max}$ . The working group felt that this last measure of sampled nonuniformity was the most natural representation of sampled uniformity. We would suggest





that this measure of uniformity, using five points, be employed when displays are compared based upon a sampled uniformity.

For colors, the maximum color difference  $\Delta u'v'$  between the most separated sampled pair of colors in the color space must be determined. You might be able to avoid having to calculate the color difference metric for all the sampled pairs if you graph the  $(u', v')$  colors and are able to clearly select the largest separation between any two sampled colors. If it is obvious which pair is furthest apart, the maximum color difference is  $\Delta u'v'$  for that pair. On the SBM reporting sheet there is a small array to permit the graphing of the  $(u', v')$  coordinates over a small area of the  $(u', v')$  space (usually a width and height of 0.1 or 0.2 will suffice). If it is difficult to clearly identify the greatest separation, graphing will at least help in selecting the most likely pairs, otherwise  $\Delta u'v'$  will have to be calculated for all pairs and the maximum determined.

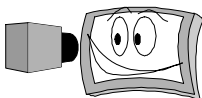
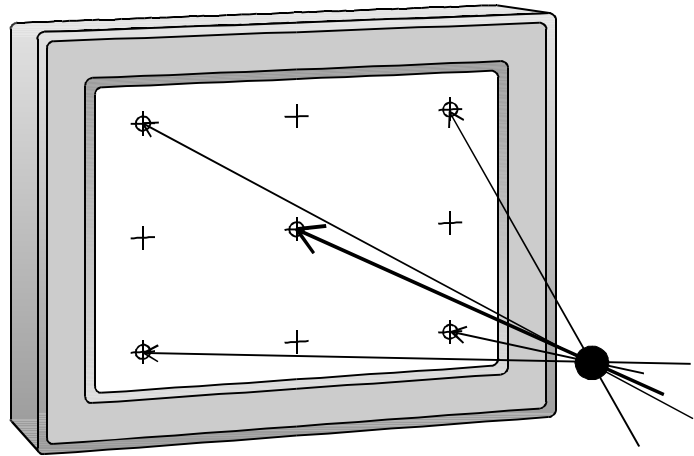


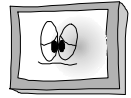
**Weighted Sampled Uniformity:** There may be a reason for weighting the sampled uniformity measurement so that more emphasis is placed on the center of the screen. Again, such a change is acceptable provided all interested parties are in agreement with the modified procedure. In such a case we would define weights  $w_i \leq 1$  associated with each sampled position  $i$ . For example, at each sampling point, a luminance measurement is made  $L_i$ . An average value for all luminances is determined  $L_{ave}$  (or the center value could be used), and a new set of modified luminances  $L_i'$  are calculated:  $L_i' = L_{ave} + w_i(L_i - L_{ave})$ . The nonuniformity, or uniformity, would then be determined based upon this new set of weighted luminances. This kind of scheme might be used for displays where the most important areas are at the center of the screen and nonuniformities at the edges of the screen are of less importance. Whatever weighting scheme is used, all interested parties must agree to the use of such uniformity metrics, and any reporting documentation must clearly state the modified procedure..

**Other Sampling Schemes:** We illustrate a symmetrical sampling of the screen using five or nine points. *The working group suggests that a five-point sampled uniformity based on the maximum luminance be used for comparisons between displays.* This is a suggestion. There may be important reasons for using other schemes, nine point, 25 point, etc. Other sampling schemes are allowed provided it is made clear in any reporting document and all interested parties agree to such modifications to the procedures. For example, one way is to divide the screen into small squares along a diagonal, one of which includes the center, along with a square in each corner of the screen. The brightest, the dimmest, and the center measurement sample points in the uniformity measurement will be used in the uniformity testing—a three point sampled uniformity. There is no objection to doing this. Simply use the same procedure with the new locations. See the ISO 13406 standard.

**Combinations:** Combinations of sampled uniformity measurements and other measurements are possible. For example, you might be interested in the uniformity of the viewing angle. This would mean making a viewing angle measurement at the uniformity sampling points. Such combinations are straightforward applications of two procedures in this document.

**Viewing Point:** In many of the following measurements, the view from the perpendicular of the flat screen surface is specified. This may not always be the type of uniformity measurement that is useful for certain displays and certain tasks. A display might look very uniform from infinity (all views perpendicular from the screen, similar to a distant viewer using a telescope to see the screen), but not have nearly the same uniformity when viewed from a typical reading distance 30 cm to 50 cm away from its center. Thus, a sampled uniformity may be more meaningful if the luminance of the display is measured through a viewing point. That is, the configuration of the luminance meter and the display is arranged so that the luminance meter is always viewing through the same point in space located at a specified direction from the normal of the screen and at a specified



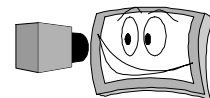


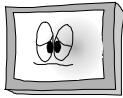
distance from the screen. This configuration replicates what you would have if you were to take a full-frame picture of the display from the position of the viewing point. Such changes are acceptable provided all interested parties are in agreement with the procedural modifications and the modifications are clearly stated in all reporting documentation.

**Average Values:** The averages calculated are the average of the data obtained. It will often be the case that any metric calculated using the average values will be different from the average value of the metric applied to each sampling position. That is, the average of the contrast ratios calculated for each point  $\Sigma L_{wi}/L_{bi}$  will, in general, not be equal to the contrast ratio of the averages  $\Sigma L_{wi}/\Sigma L_{bi}$ . In our examples this amounts to noting that the column averages cannot be directly cross-correlated along the rows. As another example, consider the  $(x_i, y_i)$  pairs that determine the color temperature of each sample point  $T_i$ . The average of the  $(x, y)$  values  $(x_{ave}, y_{ave})$  do not, in general, provide the same color temperature as the average of the color temperatures for all the sample points. [See the definition of CCT in the Glossary for a method to determine CCT from  $(x, y)$ .]

**CONTENTS:** (The \* indicates the measurement is a part of the SBM.)

- \* 306-1 SAMPLED UNIFORMITY OF WHITE
- \* 306-2 SAMPLED UNIFORMITY OF BLACK
- \* 306-3 SAMPLED UNIFORMITY OF CONTRAST RATIO
- 306-4 SAMPLED UNIFORMITY OF COLORS
- 306-5 SAMPLED UNIFORMITY OF DARK GRAY
- \* 306-6 ANOMALOUS NONUNIFORMITY





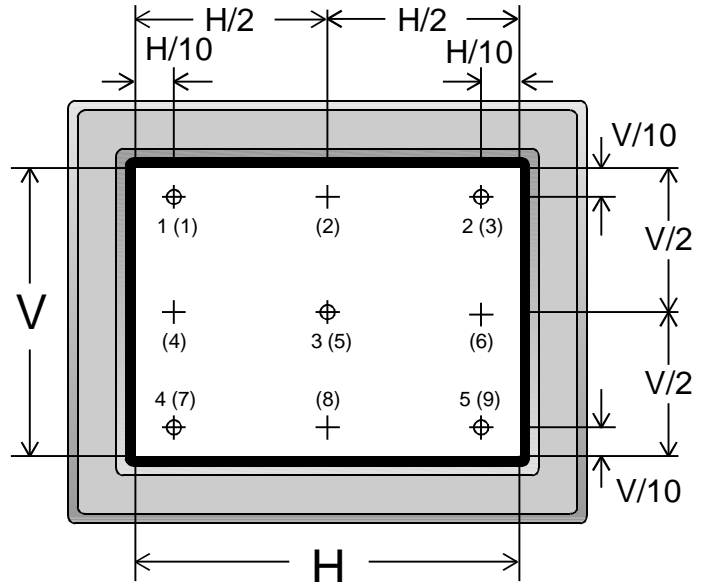
**306-1 SAMPLED UNIFORMITY & COLOR OF WHITE**  
 (luminance uniformity, full-bright uniformity)



OPTICAL

**DESCRIPTION:** We measure the luminance and (optionally) the chromaticity coordinates of full-screen white at five (or nine) specified points on the screen. The luminance nonuniformity in percent maximum deviation from the maximum white luminance and (optionally) the maximum color difference  $\Delta u'v'$  are reported. The uniformity of the correlated color temperature (CCT) can also be optionally measured. **Units:** in percent for luminance, none for color difference. **Symbol:** none.

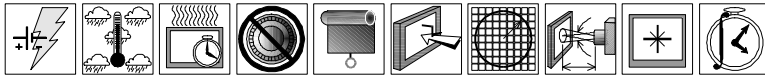
**SETUP:** Display a white full-screen test pattern and arrange the luminance meter to measure the luminance at five (or nine) positions—see the figure. The points are numbered left-to-right and top-to-bottom (as you would read English). The edge points (four or eight of them) are 1/10 the screen height and 1/10 the screen width from the edge of the image displaying surface.



⊕ Denote 5-point locations. + Denote 9-point locations.  
 1, 2, 3, 4, 5 (1), (2), (3), ..., (9)

Positioning uncertainty need only be  $\pm 3\%$  of screen diagonal. See Section 301 for any standard setup details.

**SPECIFIC:** Full screen white test pattern



**PROCEDURE:** Measure the luminance  $L_i$  ( $i=5$  or  $9$ ) and (optionally) the chromaticity coordinates [either  $(x, y)$  or  $(u', v')$ ] at the five (or nine) locations subject to above set-up conditions. Five points are suggested for comparison purposes. At the same time as measuring the white screen for luminance, you may wish to optionally record the CCT if your LMD has that capability and you need that information (see the Glossary for the determination of CCT from chromaticity coordinates).

**ANALYSIS:** From the measured set of luminance values  $L_i$  ( $i=5$  or  $9$ ) determine the minimum luminance  $L_{min}$  and the maximum luminance  $L_{max}$ , and calculate the average  $L_{ave}$ . Calculate the nonuniformity according to

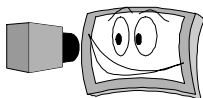
$$\text{Nonuniformity} = 100\% \frac{L_{max} - L_{min}}{L_{max}} = 100\% \left( 1 - \frac{L_{min}}{L_{max}} \right)$$

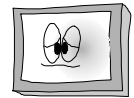
For the color of white, obtain the  $(u', v')$  coordinates either by direct measurement if your LMD will permit, or via calculation from the  $(x, y)$  chromaticity coordinates.

$$u' = \frac{4x}{3 + 12y - 2x}, \quad v' = \frac{9y}{3 + 12y - 2x}$$

Determine the largest color difference between the pairs of the sampled colors of white  $\Delta u'v'$ .

$$\Delta u'v' = \sqrt{(u'_1 - u'_2)^2 + (v'_1 - v'_2)^2}$$





**REPORTING:** Report the number of samples used. Report  $L_{min}$ ,  $L_{max}$ , and the nonuniformity to no more than three significant figures. Report the nonuniformity in percent. Report the maximum color difference to no smaller uncertainty than  $\pm 0.001$ . If CCT is optionally measured, use no more than four significant figures.

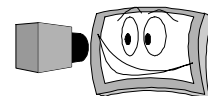
**COMMENTS:** Other color difference metrics such as  $\Delta E$  may be useful for some applications—see A201 for more information on color spaces.

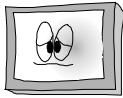
Analysis and Reporting — Sample Data									
9 pt	5 pt	$L_w$	$L_b$	$C_U$	$x_w$	$y_w$	$u'_w$	$v'_w$	CCT
1	1	109	1.02	107	0.250	0.650	0.097	0.568	6838
2									
3	2	87.8	0.91	96.5	0.235	0.690	0.087	0.574	6968
4									
5	3	115	1.05	110	0.250	0.700	0.092	0.578	6700
6									
7	4	75.1	2.15	34.9	0.262	0.765	0.090	0.591	6396
8									
9	5	97.3	1.53	63.6	0.225	0.722	0.080	0.579	7027
Ave.		96.8	1.33	82.4	Max $\Delta u'v'$ ↓ 0.024				6786
Min.		75.1	0.91	34.9					6396
Max.		115	2.15	110					7027
Nonuniformity		35	58	68					8.9

OPTICAL



Yes, I know this is late. ...  
 Yes, ... Please remove those three paragraphs.  
 ... But it is important! ...  
 But. ... I may get FIRED!  
 ... Well, can you go get it back from the printers?  
 ... You know, you're doing a great job with editing this thing....





## 306-2 SAMPLED UNIFORMITY OF BLACK

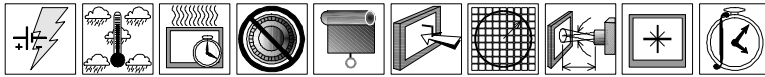


**DESCRIPTION:** We measure the luminance of full-screen black at five (or nine) specified points on the screen and report the nonuniformity in percent maximum deviation from the maximum black luminance. **Units:** in percent. **Symbol:** none.

The uniformity of black can be very important to some display tasks, particularly when large areas of black are used or the display is used in a dark room.

**SETUP:** Display a black full-screen test pattern, and arrange the luminance meter to measure the luminance at five (or nine) positions—see the figure. The points are numbered left-to-right and top-to-bottom (as we would read English). The edge points (four or eight of them) are 1/10 the screen height and 1/10 the screen width from the edge of the image displaying surface. Positioning uncertainty need only be  $\pm 3\%$  of screen diagonal, the normal direction should be maintained. See Section 301 for any standard setup details.

**SPECIFIC:** Full screen black test pattern



**PROCEDURE:** Measure the luminance  $L_i$  ( $i=5$  or  $9$ ) at the five (or nine) locations subject to above set-up conditions.

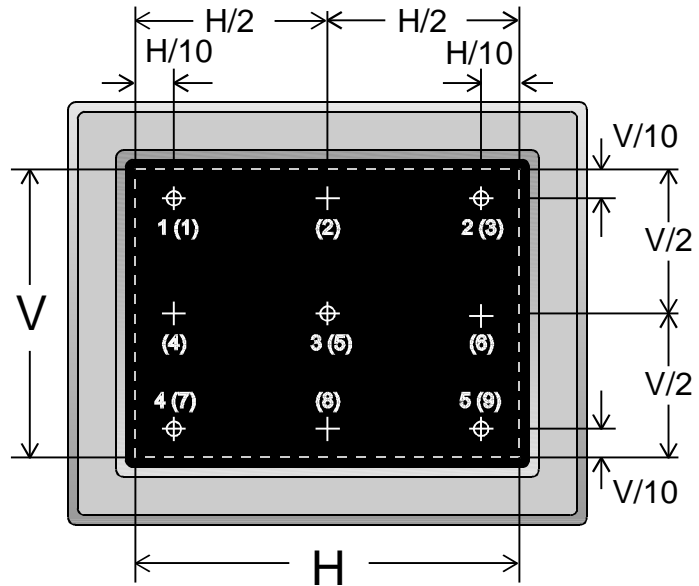
**ANALYSIS:** From the measured set of luminance values  $L_i$  ( $i=5$  or  $9$ ) determine the minimum luminance  $L_{\min}$  and the maximum luminance  $L_{\max}$ . Calculate the average  $L_{\text{ave}}$ . Calculate the nonuniformity according to

$$\text{Nonuniformity} = 100\% \frac{L_{\max} - L_{\min}}{L_{\max}} = 100\% \left( 1 - \frac{L_{\min}}{L_{\max}} \right).$$

**REPORTING:** Report the number of samples used. Report  $L_{\min}$ ,  $L_{\max}$ , and the nonuniformity to no more than three significant figures. Report the nonuniformity in percent.

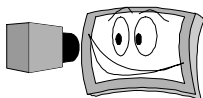
**COMMENTS:** Measurements of black can be subject to large errors.

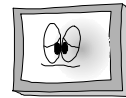
Be sure your LMD is adequate for the task. Since a ratio of luminance levels is used in determining the nonuniformity, the LMD does not have to be calibrated in  $\text{cd}/\text{m}^2$ , but it must be linear and photopic.



⊕ Denote 5-point locations. + Denote 9-point locations.  
1, 2, 3, 4, 5 (1), (2), (3), ..., (9)

Analysis and Reporting (Sample Data)		
Nonuniformity = $100\% (L_{\max} - L_{\min}) / L_{\max}$		
9 point	5 point	$L_b - \text{cd}/\text{m}^2$
1	1	1.02
2		
3	2	0.910
4		
5	3	1.05
6		
7	4	2.15
8		
9	5	1.53
Ave.		1.33
$L_{\min}$		0.910
$L_{\max}$		2.15
Nonuniformity		58





**306-3 SAMPLED UNIFORMITY OF CONTRAST RATIO**



**DESCRIPTION:** We calculate the contrast ratio at each of the five (or nine) points of full-screen sampled white uniformity (306-1) and full-screen sampled black uniformity (306-2) and report the nonuniformity of contrast in percent maximum deviation from the maximum contrast. **Units:** none, it is a ratio. **Symbol:**  $C_U$ .

Contrast uniformity may be important for critical tasks where proper scene or pattern rendering is important to proper recognition or presentation of information.

**SETUP:** None. Uniformity measurements of full-screen white and black are made previously.

**PROCEDURE:** None. Uniformity measurements of full-screen white and black are made previously.

**ANALYSIS:** Calculate the contrast ratio  $C_U = L_w / L_b$  for each sampled point on the screen. Determine the maximum and minimum contrast  $C_{max}$ ,  $C_{min}$ , and calculate the contrast nonuniformity

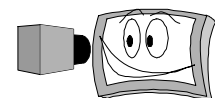
$$\text{Nonuniformity} = 100\% \frac{C_{max} - C_{min}}{C_{max}} = 100\% \left( 1 - \frac{C_{min}}{C_{max}} \right)$$

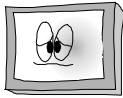
**REPORTING:** Report the contrast ratios to no more than three significant figures. Report the nonuniformity as a percent to no more than two significant figures.

**COMMENTS:** Other contrast metrics than a simple ratio of white to black luminances may be found to be useful.

Analysis and Reporting - Sample Data				
Nonuniformity = 100% (1 - C <sub>min</sub> /C <sub>max</sub> )				
9 point	5 point	L <sub>w</sub> - cd/m <sup>2</sup>	L <sub>b</sub> - cd/m <sup>2</sup>	C <sub>U</sub>
1	1	109	1.02	107
2				
3	2	87.8	0.91	96.5
4				
5	3	115	1.05	110
6				
7	4	75.1	2.15	34.9
8				
9	5	97.3	1.53	63.6
Ave.		96.8	1.33	82.4
Min.		75.1	0.91	34.9
Max.		115	2.15	110
Contrast Nonuniformity			68	

OPTICAL



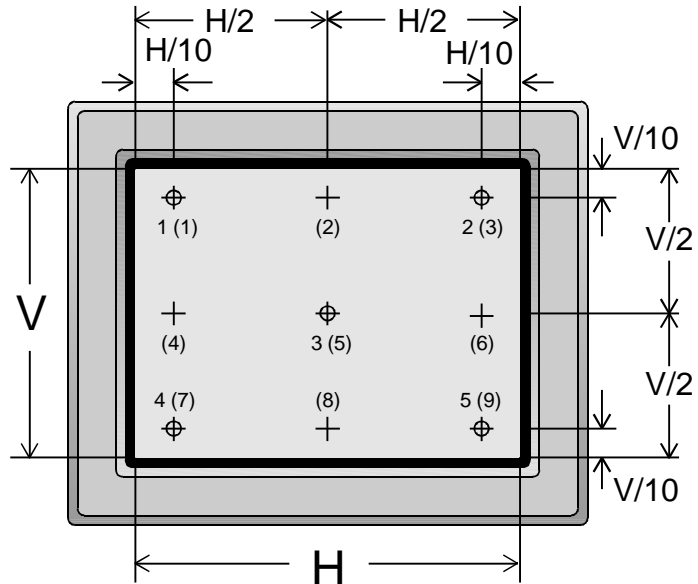


### 306-4 SAMPLED UNIFORMITY OF COLORS

**DESCRIPTION:** We measure the luminance and chromaticity coordinates of any full-screen color at five (or nine) specified points on the screen and report the luminance nonuniformity and maximum color difference. **Units:** in percent for luminance, none for color difference. **Symbols:** none.

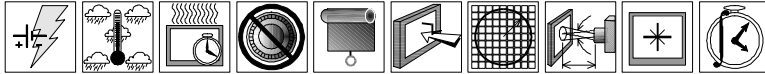
The uniformity of colors can be important in realistic rendering of objects on the screen. The uniformity involves not only the luminance but also the color as measured by chromaticity coordinates. This procedure permits any color to be used (white and gray are also colors), but often there is interest in the uniformity of the primary or secondary colors.

**SETUP:** Display a colored full-screen test pattern, and arrange the luminance meter to measure the luminance at five (or nine) positions—see the figure. The points are numbered left-to-right and top-to-bottom (as you would read English). The edge points (four or eight of them) are 1/10 the screen height and 1/10 the screen width from the edge of the image displaying surface. Positioning uncertainty need only be  $\pm 3\%$  of screen diagonal, the normal direction should be maintained. See Section 301 for any standard setup details.



⊕ Denote 5-point locations. + Denote 9-point locations.  
1, 2, 3, 4, 5 (1), (2), (3), ..., (9)

**SPECIFIC:** Full screen color test pattern



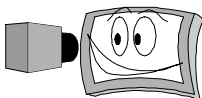
**PROCEDURE:** Measure the luminance  $L_i$  ( $i=5$  or  $9$ ) and the chromaticity coordinates [either  $(x, y)$  or  $(u', v')$ ] at the five (or nine) locations subject to above set-up conditions.

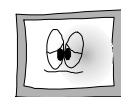
**ANALYSIS:** From the measured set of luminance values  $L_i$  ( $i=5$  or  $9$ ) determine the minimum luminance  $L_{min}$  and the maximum luminance  $L_{max}$ , and calculate the average  $L_{ave}$ . Calculate the nonuniformity. For the color, obtain the  $(u', v')$  coordinates either by direct measurement if your LMD will permit, or via calculation from the  $(x, y)$  chromaticity coordinates. Determine the largest color difference between the pairs of the sampled colors of white  $\Delta u'v'$ . (We suggest you graph the  $(u', v')$  and narrow down the largest differences rather than calculate all pairs of  $\Delta u'v'$ )

**REPORTING:** Report the number of samples used. Report  $L_{min}$ ,  $L_{max}$ , and the nonuniformity to no more than three significant figures. Report the nonuniformity in percent. Report the maximum color difference to no smaller uncertainty than  $\pm 0.001$ . If CCT is optionally measured, use no more than four significant figures.

**COMMENTS:** Other color difference metrics such as  $\Delta E$  may be useful for some applications—see A201 for more information on color spaces.

Analysis and Reporting — Sample Data						
9 pt	5 pt	$L$	$x$	$y$	$u'$	$v'$
1	1	109	0.250	0.650	0.097	0.568
2						
3	2	87.8	0.235	0.690	0.087	0.574
4						
5	3	115	0.250	0.700	0.092	0.578
6						
7	4	75.1	0.262	0.765	0.090	0.591
8						
9	5	97.3	0.225	0.722	0.080	0.579
Ave.		96.8				(0.2,
Min.		75.1	Max			0.7)
Max.		115	$\Delta u'v'$			
Nonunif.		35	0.024	0.5)		



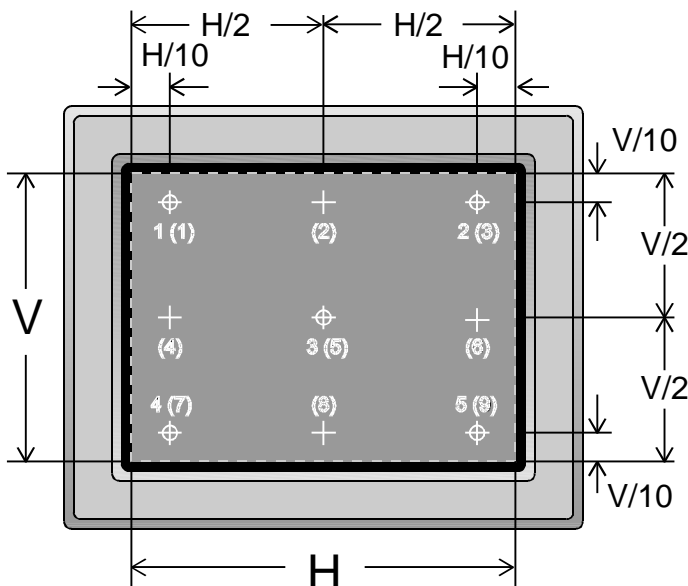


### 306-5 SAMPLED UNIFORMITY OF DARK GRAY

**DESCRIPTION:** We measure the luminance of full-screen dark gray at five (or nine) specified points on the screen and report the percent maximum deviation from the average value. (Optionally, the chromaticity coordinates can also be measured and the maximum color shift  $\Delta u'v'$  be determined) **Units:** in percent. **Symbols:** none.

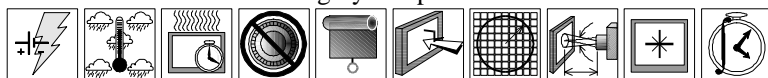
Dark gray screens can sometimes reveal more nonuniformities than either white or black.

**SETUP:** Display a dark gray full-screen test pattern having a luminance of from 3 % to 5 % of the full-screen white luminance. Arrange the luminance meter to measure the luminance at five (or nine) positions—see the figure. The points are numbered left-to-right and top-to-bottom (as you would read English). The edge points (four or eight of them) are 1/10 the screen height and 1/10 the screen width from the edge of the image displaying surface. Positioning uncertainty need only be  $\pm 3\%$  of screen diagonal. See Section 301 for any standard setup details.



⊕ Denote 5-point locations. 1, 2, 3, 4, 5  
 + Denote 9-point locations. (1), (2), (3), ..., (9)

**SPECIFIC:** Full screen dark gray test pattern



**PROCEDURE:** Measure the luminance  $L_i$  ( $i=5$  or  $9$ ) at the five (or nine) locations subject to above set-up conditions. Optionally measure the chromaticity coordinates.

**ANALYSIS:** From the measured set of luminance values  $L_i$  ( $i=5$  or  $9$ ) determine the minimum luminance  $L_{min}$  and the maximum luminance  $L_{max}$ , and calculate the average  $L_{ave}$ . Calculate the nonuniformity according to

$$\begin{aligned} \text{Nonuniformity} &= 100\% \frac{L_{max} - L_{min}}{L_{max}} \\ &= 100\% \left( 1 - \frac{L_{min}}{L_{max}} \right) \end{aligned}$$

Optionally calculate the largest color shift  $\Delta u'v'$ .

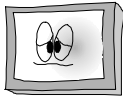
**REPORTING:** Report the number of samples used. Report  $L_{min}$ ,  $L_{max}$ , and the nonuniformity to no more than three significant figures.

Report the nonuniformity in percent. Optionally report any color shift in  $\Delta u'v'$  to no more than three significant figures.

**COMMENTS:** Another color difference metric than  $\Delta u'v'$  may be used if all interested parties agree.

Analysis and Reporting (Sample Data)		
Nonuniformity = $100\% (L_{max} - L_{min}) / L_{max}$		
Center FullScrn White		115
Center Dark Gray		4.83
Gray Level (0-7)		1 (4.2 )
9 point	5 point	$L_i - \text{cd/m}^2$
1	1	4.02
2		
3	2	5.35
4		
5	3	4.83
6		
7	4	8.72
8		
9	5	6.97
Ave.		5.98
$L_{min}$		4.02
$L_{max}$		8.72
Nonuniformity		54

OPTICAL

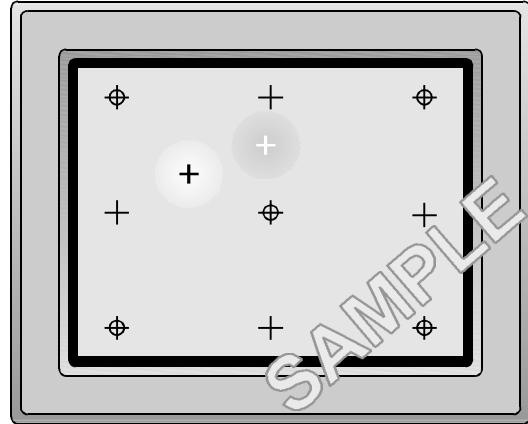


### 306-6 ANOMALOUS NONUNIFORMITY



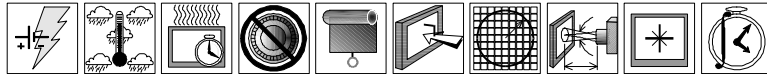
**DESCRIPTION:** Measure the luminance and optionally the chromaticity coordinates of full-screen white at the dimmest (darkest) and the brightest areas (spots) (or the areas that exhibit the largest color shift) and calculate the nonuniformity. **Units:** in percent. **Symbols:** none.

Anomalous nonuniformity is a measure of the worst-case nonuniformity for the standard measurement area of the LMD (500 pixels). It is particularly useful when the sampled uniformity measurement shows little nonuniformity, but there are obvious areas or spots between the sampled points that are clearly nonuniform. See the figure where we show two areas (spots) on a full white screen that show an obvious nonuniformity that the sampled uniformity measurements with five or nine sample points would miss. One spot in the figure is brighter than most of the rest of the white screen, and the other spot is darker. (This is not always necessarily the case. The screen can have either a dark spot or a light spot that differs from most of the rest of the screen.) This measurement is for those anomalous bad regions that cover an area of 500 pixels or more—this is not a measurement of pixel defects in a small several-pixel-size region of the screen. If there are no obvious regions of nonuniformity, then this measurement may not be useful. Optionally, for color there can be objectionable color changes not on the sampled uniformity points that need to be documented.



**SETUP:** Display a white full-screen test pattern. Arrange the luminance meter to measure the luminance and optionally the chromaticity coordinates at the brightest spot and the darkest or dimmest spot (or the two spots that exhibit the largest color shift)—see the figure. See Section 301 for any standard setup details.

**SPECIFIC:** Full screen black test pattern



**PROCEDURE:** Measure the luminance of the center of the brightest spot  $L_{max}$  and then the center of the darkest or dimmest spot  $L_{min}$  subject to above set-up conditions, or at the two spots that exhibit the largest color difference. The chromaticity coordinates can also be measured if the luminance uniformity is being characterized.

**ANALYSIS:** Calculate the nonuniformity. 
$$\text{Nonuniformity} = 100\% \frac{L_{max} - L_{min}}{L_{max}} = 100\% \left( 1 - \frac{L_{min}}{L_{max}} \right)$$

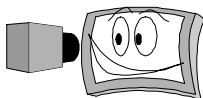
Optionally, calculate the color difference  $\Delta u'v' = \sqrt{(u'_1 - u'_2)^2 + (v'_1 + v'_2)^2}$ .

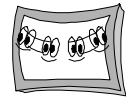
**REPORTING:** Report  $L_{min}$ ,  $L_{max}$ , and the nonuniformity to no more than three significant figures. Report the nonuniformity in percent. Optionally, report the chromaticity coordinates and the  $\Delta u'v'$  color difference metric. Report the maximum color difference to no smaller uncertainty than  $\pm 0.001$ . It may or may not be useful to report the location of the measured spots.

**COMMENTS:** See 301-3d Mura Assessment and 301-3g Video and Image Artifacts Assessment for related descriptions of nonuniformity.

Analysis and Reporting — Sample Data					
	$L_w$	$x_w$	$y_w$	$u'_w$	$v'_w$
An. Low	125	0.250	0.650	0.097	0.568
An. High	55.3	0.225	0.722	0.080	0.579
An. Non.	56	Anomalous $\Delta u'v'$		0.020	

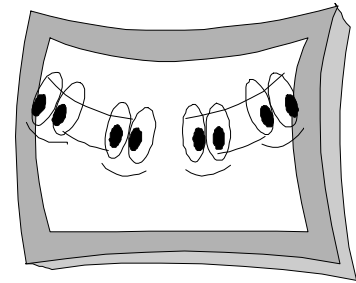
OPTICAL





## 307 VIEWING ANGLE PERFORMANCE

The viewing angle characteristics of the display are measured by making center measurements of full screen (as described in Section 302) at off-normal viewing angles. The different methods for the viewing angle measurements specified in this section (307-1, -2, -3, -4, -5) are similar except for the number of viewing angles measured. The following viewing angle measurements are specified (an \* denotes the measurement is part of the SBM):



**\*307-1 FOUR-POINT (H&V) VIEWING ANGLE** - This simple viewing angle measurement verifies manufacturer's claims at four horizontal and vertical (H&V) viewing angles about the screen, two horizontal, right, and left, and two vertical, up, down.

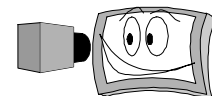
**307-2 THRESHOLD H&V VIEWING ANGLES** - This is a procedure to measure the four horizontal and vertical (H&V) viewing angles that meet an arbitrarily-defined threshold level of full-screen white luminance, full screen black luminance, contrast ratio, or color variation. H&V angles are determined for viewing directions where luminance varies by 50 % of the perpendicular value, or any other agreed-upon threshold value. Viewing angles are determined for contrast ratio ( $C_T = L_w/L_b$ ), where  $C_T = 10, 20, 50$ , or any other agreed-upon threshold value of contrast ratio such as 50 % of the perpendicular value. H&V angles are determined for viewing directions where color varies by  $\Delta C = 5$  relative to the perpendicular value, or any other agreed-upon threshold value of color shift.

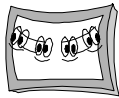
**307-3 GRAY-SCALE INVERSION H & V VIEWING ANGLES** - This measurement determines the H&V viewing directions at which contrast between any two adjacent gray levels diminishes to a value of one—the gray-scale inversion angles, by measuring the full-screen contrast ratio at the center of the screen for each of 8 gray levels (optionally 16) over a range of vertical and horizontal viewing angles, and computing the contrast ratio between two adjacent gray-level pairs. *NOTE: This measurement may not be useful for all displays that experience changes in the gray scale with viewing angle changes. Sometimes the levels don't quite cross, but it is hard to tell for certain. Sometimes the crossing is at such a small angle that it is very difficult to precisely determine the location of the crossover. In such cases the applicability of this measurement must be negotiated with all interested parties.*

**307-4 VIEWING CONE THRESHOLDS** - Similar to Section 307-2 for H&V viewing angles, this is a complex measurement of the full angular variation of the light for most of the  $2\pi$ -solid-angle hemisphere to determine those viewing angles that meet an arbitrarily-defined threshold level of change in full-screen luminance, contrast ratio, and color variation. Measurements are made at 300 to 400 different viewing angles to characterize the viewing cone in a  $360^\circ$  polar plot of data measured at five degree intervals of inclination angle relative to the normal direction and  $10^\circ$  intervals of azimuth (rotation) angle.

**307-5 GRAY-SCALE INVERSION VIEWING CONE** - Similar to Section 307-3 for H&V viewing angles, this complex measurement determines the viewing directions at which contrast between any two adjacent gray levels diminishes to a value of one—the gray-scale inversion angles, by measuring the full-screen contrast ratio at the center of the screen for each of 8 gray levels (optionally 16) over most of the  $2\pi$  solid angle hemisphere.

**REMARK:** The gray-scale inversion metrics described in 307-3 and 307-5 can also be extended to color inversions as functions of gray level and angle, as described at the end of Section 307-5.

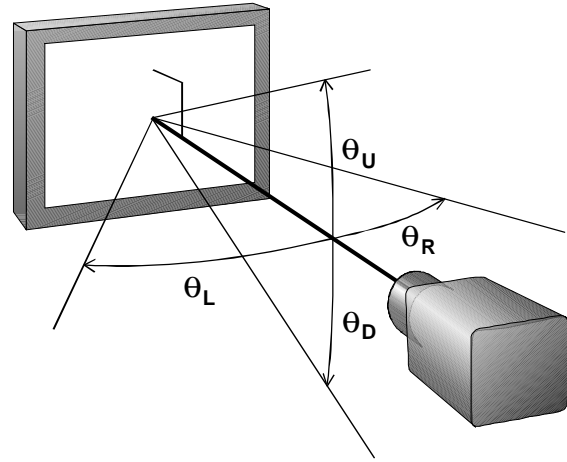




## 307-1 FOUR-POINT VIEWING ANGLE

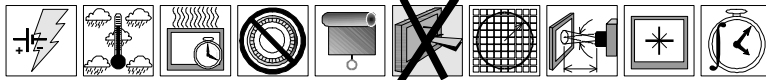
**DESCRIPTION:** We measure any optical quantity at the center of the screen at four viewing angles relative to the perpendicular direction (two vertical angles, up and down ; and two horizontal angles, right and left) specified by the display manufacturer. The resulting optical quantities are then compared with the manufacturer’s specifications.

For example, manufacturers often describe the full-screen contrast ratios attainable at four angles about the screen. This is a procedure to confirm these claims. Instead of contrast ratios, the white luminance, black luminance, chromaticity coordinates, color difference metrics compared to a perpendicular measurement of the center screen, color temperature, etc., can all be evaluated at these four points and compared with corresponding manufacturing data.



**SETUP:** Arrange the LMD to measure the desired optical quantity at screen center from the normal direction. Use a goniometric positioning device such as a rotating platter or discrete angle gauge blocks to assure an accurate angular alignment ( $\pm 1^\circ$ ) between the LMD and the screen normal for the four off-normal viewing directions: upward  $q_V = q_U$ , downward  $q_V = -q_D$ , sideways to the right  $q_H = q_R$ , and sideways to the left  $q_H = -q_L$ . See Section 301 for any standard setup details.

**SPECIFIC:** Full screen patterns appropriate to the optical quantities to be measured.



**PROCEDURE:** Make measurements of the desired optical quantities at center screen with the LMD positioned at each of the four off-normal viewing angles.

**ANALYSIS:** For each of the four viewing directions perform any required calculations (as with contrast, color metrics, etc.). (See 302, Center Measurements of Full Screen, for any details.)

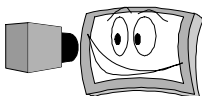
Analysis and Reporting — Viewing Angle Sample Data										
Direction	Angle	White				Black				
		$L_w$	$x_w$	$y_w$	CCT	$L_b$	$x_b$	$y_b$	$C_R$	
Up: $q_U$	15°	85.6	0.298	0.322	7478	1.59	0.271	0.292	52.9	
Down: $q_D$	10°	111	0.322	0.348	5967	3.79	0.269	0.285	29.2	
Right: $q_R$	30°	39.4	0.323	0.346	5903	0.553	0.268	0.290	71.2	
Left: $q_L$	30°	39.9	0.323	0.345	5920	0.609	0.270	0.297	65.4	
Direction	Angle	Red			Green			Blue		
		$L_{red}$	$x_{red}$	$y_{red}$	$L_{gm}$	$x_{gm}$	$y_{gm}$	$L_{blu}$	$x_{blu}$	$y_{blu}$
Up: $q_U$	15°	25.9	0.521	0.350	50.2	0.296	0.521	16.1	0.157	0.140
Down: $q_D$	10°	35.4	0.520	0.349	63.5	0.305	0.518	20.3	0.166	0.165
Right: $q_R$	30°	12.1	0.550	0.354	22.5	0.307	0.541	6.23	0.158	0.150
Left: $q_L$	30°	12.3	0.548	0.353	22.7	0.306	0.540	6.34	0.158	0.150

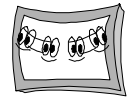
**REPORTING:**

Report the optical quantities measured and/or calculated. In the example we show a variety of measurements: luminance and chromaticity coordinates of full-screen white and black, color temperature, chromaticity coordinates and luminances of primary colors, and contrast.

**COMMENTS:** This measurement is a verification of the manufacturer’s specifications for the optical properties attainable at specified H&V viewing angles. The manufacturer must specify the angles and the value of the optical property to be measured at those angles.

OPTICAL



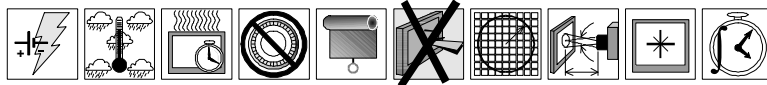


## 307-2 THRESHOLD-BASED H&V VIEWING ANGLES

**DESCRIPTION:** Measure the viewing angles up, down, left, and right that meet arbitrarily-defined threshold levels of full-screen luminance, contrast ratio, and/or color variation.

Horizontal and vertical (H&V) angles are determined for viewing directions where luminance varies by 50 % of the perpendicular value, or any other agreed-upon threshold value. Viewing angles are determined for a threshold contrast ( $C_T = L_w/L_b$ ) condition of 10:1 (optionally other threshold contrasts) using black-and-white full-screen center luminance measurements. Other contrasts may be specified to be the viewing angle where center full-screen contrast  $C_R = L_w/L_b$  degrades by 50 % from its perpendicular (not necessarily the maximum) value. Similarly, the viewing angles associated with a change of black toward white by a small fraction of the white level, e.g., 5 % of  $L_w$ , could also be specified. H&V angles are determined for viewing directions where color varies by  $\Delta E = 5$  relative to the perpendicular value, or any other agreed-upon value of color shift. The viewing angle for the threshold condition is obtained from linear interpolation of contrast data as a function of angles with the angular increment no greater than  $5^\circ$  in each of the four directions, up, down, left, and right, relative to the screen perpendicular. **Units:** none, a ratio. **Symbol:**  $C_T$  for viewing angle contrast threshold.

**SETUP:** Arrange the luminance meter to measure the luminance at screen center from the perpendicular direction. Use a goniometric positioning device such as a rotating platter or discrete angle gauge blocks to assure accurate angular alignments ( $\pm 1^\circ$ ) between the luminance meter and the screen perpendicular. Incrementally increase the angles from the perpendicular with a maximum increment of  $5^\circ$  in off-normal viewing directions: upward  $q_U$ , downward  $q_D$ , right  $q_R$ , and left  $q_L$ . Optionally, a colorimeter is required for obtaining CIE chromaticity coordinates or correlated color temperature (CCT) of white. See Section 301 for any standard setup details.

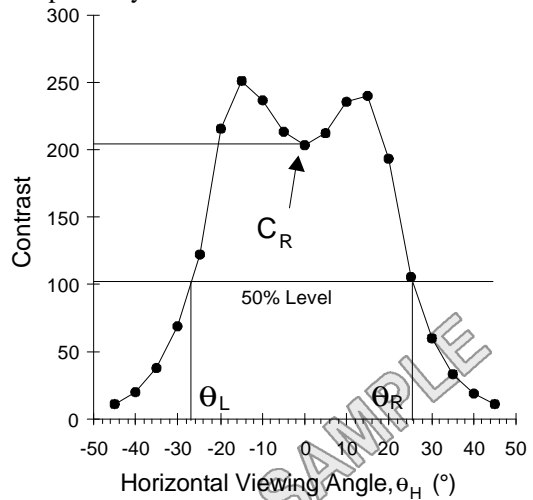


**SPECIFIC:** Full screen white and black patterns alternated (optionally primary colors).

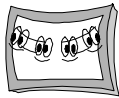
**PROCEDURE:** Make luminance measurements of full white and of full black at center screen with the luminance meter positioned at each of the off-normal H&V viewing angles. Optionally measure and record the CIE chromaticity coordinates of white, black, the full-screen primary colors, and/or the CCT of white.

**ANALYSIS:** For each white and black screen luminance measurement, compute the contrast ratio of white to black. Calculate the color difference values in  $\Delta U^*V^*$  or  $\Delta E$  units for each of the CIE  $x,y$  chromaticity coordinates measured on a full white screen using the perpendicular viewing direction as reference. Use linear interpolation to compute the four angular viewing directions upward  $q_U$ , downward  $q_D$ , right  $q_R$ , and left  $q_L$  that correspond to threshold levels of: (1) luminance, such as 50 % from its perpendicular value, (2) contrast ratio, such as  $C_T = 10$  (or other values such as 20, 50, or as previously agreed upon), and (3) color difference such as  $\Delta U^*V^* = 0.01$  or  $\Delta E = 5$ .

**REPORTING:** Report the viewing angles up, down, left, and right, for each threshold luminance, contrast ratio, and color difference to no more than three significant figures. Optionally, present plots of the computed contrast ratios, measured luminance values, chromaticity coordinates (or CCT) of white, and computed values of  $\Delta U^*V^*$  or  $\Delta E$  units along H&V axes.



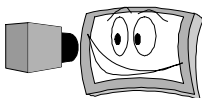
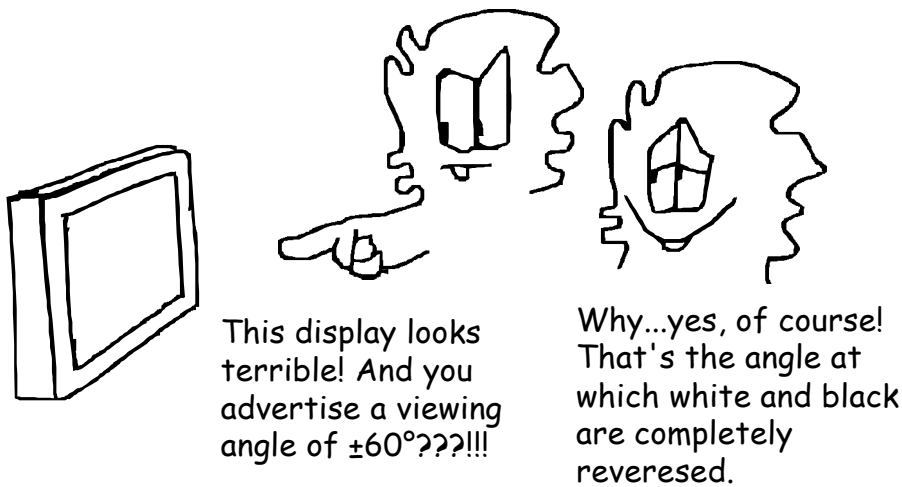
**Fig. 1.** Example of full-screen contrast ratio along the horizontal viewing angle.

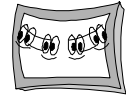


**COMMENTS:** This measurement may be used to verify manufacturer’s specifications for the contrasts attainable at specified H&V viewing angles. The 50 % contrast degradation level is similar to the 3dB falloff used as a measuring point in electronics. The extreme maximum contrast of a display may not necessarily be determined by this measurement since the viewing directions are limited to those tilted vertically along the y-axis and tilted horizontally along the x-axis of the display. A more complete assessment of the display dependencies on viewing direction is obtained through measurement of the full viewing angle cone presented in Section 307-4. Measurement of color difference of low-luminance black screens is not recommended due to limitations in sensitivity of most color meters (filter colorimeters, spectrometers, and spectroradiometers) Long integration times required to accurately measure color of many low luminance points along the viewing cone is considered impractical.

Reporting — Sample Data		
Threshold Contrast Viewing Angles		
	$C_T = 100$	$C_T = 50$
Direction	Angle	Angle
Up: $q_U$	11.2°	15.0°
Down: $q_D$	3.81°	7.12°
Right: $q_R$	23.5°	27.2°
Left: $q_L$	32.1°	33.2°

OPTICAL





### 307-3 GRAY-SCALE INVERSION

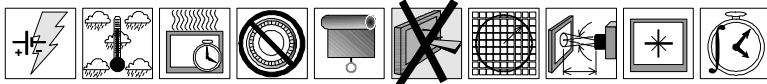
**DESCRIPTION:** This is a procedure to determine the gray-level inversion angles, which are the viewing directions for which the contrast ratio between any two adjacent gray levels diminishes to a value of one (the gray levels become indistinguishable).

This is done by measuring the full-screen contrast ratio at the center of the screen between pairs of each of 8 gray levels (optionally 16) over a range of horizontal and vertical (H&V) viewing angles. (Other angles than horizontal or vertical can be used provided all interested parties agree and they are clearly documented in any report. We limit our description to the horizontal and vertical since these are the most common directions used.) Viewing angles up, down, left, and right that meet the 1:1 threshold level of full-screen contrast ( $C_T = L_i/L_{i+1}$ ,  $i = \text{level}$ ) are determined from center-screen luminance measurements. The reported angle for the threshold condition is obtained by linear interpolation of contrast data measured as a function of H&V angles with the angular increment no greater than  $5^\circ$  in each of the four directions relative to the screen perpendicular. **Units:** none, a ratio. **Symbol:**  $C_T$  for consecutive gray-scale luminance ratio threshold.

**NOTE:** This measurement may not be useful for all displays that experience changes in the gray scale with viewing angle changes. Sometimes the levels don't quite cross, but it is hard to tell for certain. Sometimes the crossing is at such a small angle that it is very difficult to precisely determine the location of the crossover. Sensitivity to small signal changes can also be dramatic. In such cases the applicability of this measurement must be negotiated with all interested parties.

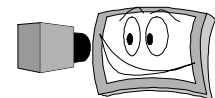
**SETUP:** Arrange the luminance meter to measure the luminance of each of eight (optionally 16) full-screen gray test patterns from black to white at screen center using a goniometric positioning device such as a rotating platter or discrete angle gauge blocks to assure an accurate angular alignment ( $\pm 1^\circ$ ) between the luminance meter and the screen perpendicular in vertical and horizontal viewing directions. It is helpful to establish initial approximations to the needed angles by visually inspecting a small target containing all the gray levels displayed near the center of the screen. (This can save taking a large amount of data, see Procedure). See Section 301 for any standard setup details.

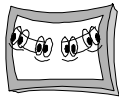
**SPECIFIC:** Full screen gray levels. See Section 303-5 or the glossary for details if it is not clear how to establish gray levels.



**PROCEDURE:** To obtain an approximate location of such gray-scale inversion points, it may be helpful to place a small target at center screen composed of all the gray levels in a pie shape or overlapping rectangles. The eye is very sensitive to edges and will quickly spot the angular locations of any gray-scale inversion. For each gray-scale pair establish the approximate angles for each main direction, up, down, left, and right; and record the number or value of the levels that become equal in luminance. If you use the gray-scale target to establish approximate inversion angles, you will be able to limit the data collected to luminance levels at those angles and at  $\pm 5^\circ$  on each side of those angles.

If you don't use the gray-scale target to establish approximations to the inversion angles, then the following laborious procedure will be required: Make luminance measurements of each full screen gray scale test pattern from white to full black at center screen with the luminance meter positioned at each of the off-normal vertical and horizontal viewing angles. Incrementally increase the angles from the perpendicular with a maximum increment of  $5^\circ$  in off-normal viewing directions (upward  $q_U$ , downward  $q_D$ , right  $q_R$ , and left  $q_L$ ) to determine the angles of view at which the luminance of the higher gray level,  $n+1$ , equals (and is therefore indistinguishable from) that of the lower gray level,  $n$ . See Section 301 for any standard setup details.

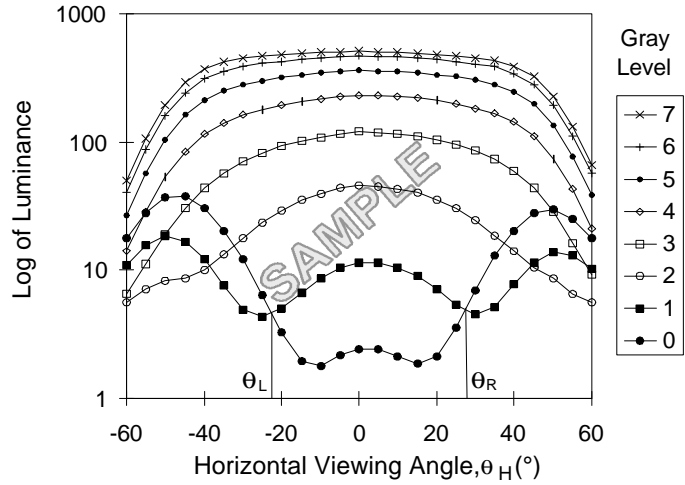




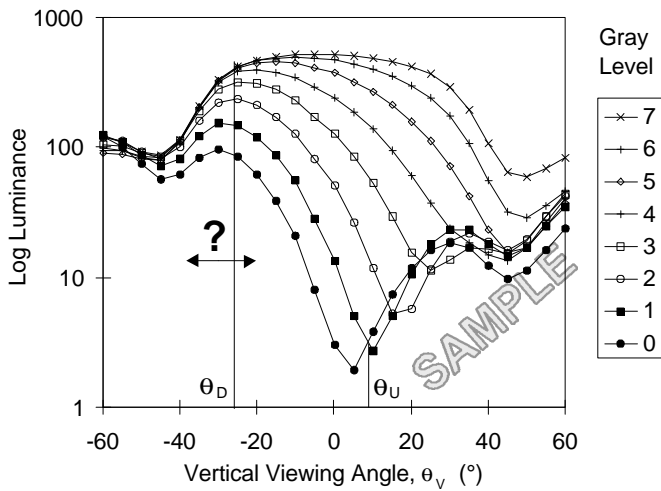
**ANALYSIS:** Use linear interpolation to compute the inversion angle viewing directions from the angle measurements on each side of the inversion angle corresponding to  $L_n = L_{n+1}$  for each adjacent gray level pair. Note that it would be prudent to position the LMD at these calculated angles and check the luminance of the gray levels in the event that a linear interpolation is not adequate to determine the inversion angle—a small correction of the angle’s value may be needed.

**REPORTING:** Report the smallest (worst case) angles for which an inversion occurs between any adjacent gray-level pair for each direction, up, down, left, and right to no more than three significant figures. Optionally, report all the viewing angles for each adjacent gray-level pair.

**COMMENTS:** This measurement is a determination of the viewing angles at which gray scale inversion occurs. The minimum angular range of gray scale inversion of a display may not necessarily be determined by

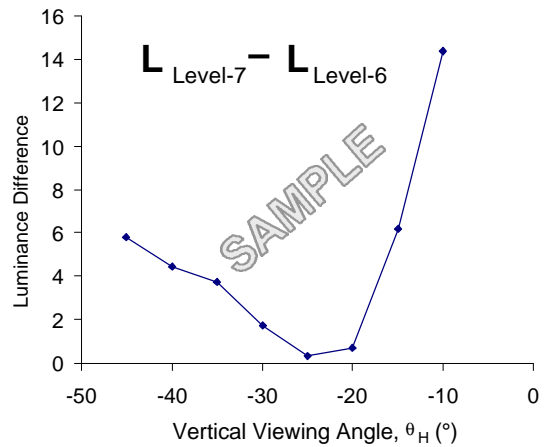


**Fig. 1.** Luminance in  $\text{cd}/\text{m}^2$  vs. horizontal viewing angle with gray-scale inversion angles clearly defined.



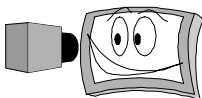
**Fig. 2.** Luminance vs. vertical viewing angle with gray-scale inversion not clearly defined.

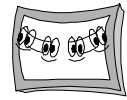
this measurement since the viewing directions are limited to those tilted vertically along the y-axis and tilted horizontally along the x-axis of the display. A more complete assessment of the display gray scale dependencies on viewing direction is obtained through measurement of the gray-scale angular dependence over the full viewing angle cone presented in Section 307-5. See the note in the Comments of Section 307-5 for possible ways to extend to color inversion.



**Fig. 3.** Difference in luminance between level 7 and level 6 showing that they don’t cross over and there is no gray-scale inversion (but it is close).

Analysis and Reporting Grayscale Inversion Viewing Angles			
Direction	$C_T = 1$ Angle	Gray Level Pair (0-7)	
		$L_{n+1}$	$L_n$
Up: $q_U$	$8.7^\circ$	level 1	level 0
Down: $q_D$	min. at $25^\circ$	level 1	level 0
Right: $q_R$	$27.2^\circ$	level 1	level 0
Left: $q_L$	$22.3^\circ$	level 7	level 6





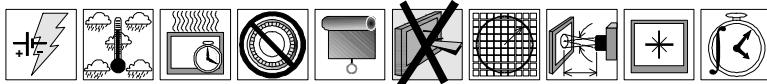
## 307-4 VIEWING-CONE THRESHOLDS

**DESCRIPTION:** Full screen luminance and chromaticity measurements are made at the center of the screen to create 360° polar plots identifying the location (locus of points on a two-dimensional curve) of threshold values for any optical quantity of interest—the luminance, chromaticity, a color metric, or contrast.

The data are measured at five degree intervals of inclination angle relative to the normal direction and 10 degrees intervals of azimuth ( $f$  rotation) angles to determine the viewing angles from the perpendicular where a criterion or threshold is met. For example, (1) the center full-screen luminance changes to an arbitrarily defined size such as 50 % (or other threshold) of its perpendicular value, (2) the full screen contrast ratio meets a threshold contrast ( $C_T = L_w/L_b$ ) condition of 10:1 (optionally other contrast ratios) and, (3) the color changes noticeably such as  $\Delta U'V' = 0.1$  compared to the perpendicular. Use linear interpolation to determine the viewing angles from those measured. **Units:** none, a ratio. **Symbol:**  $C_T$ .

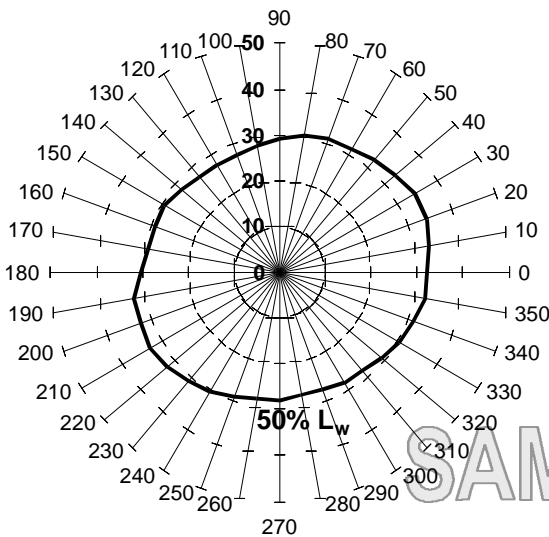
**SETUP:** Arrange the luminance meter to measure the luminance and chrominance (such as CIE  $x, y$  coordinates) at screen center from the normal direction. Use a goniometric positioning device such as a rotating platter or motorized positioning system to assure an accurate angular alignment ( $\pm 1^\circ$ ) between the luminance meter and the screen normal for incremental increases in off-normal viewing directions, 5 degree maximum increment size for inclination, 10 degree maximum increment for azimuth.

**SPECIFIC:** Full screen white and black patterns alternated (optionally primary colors)

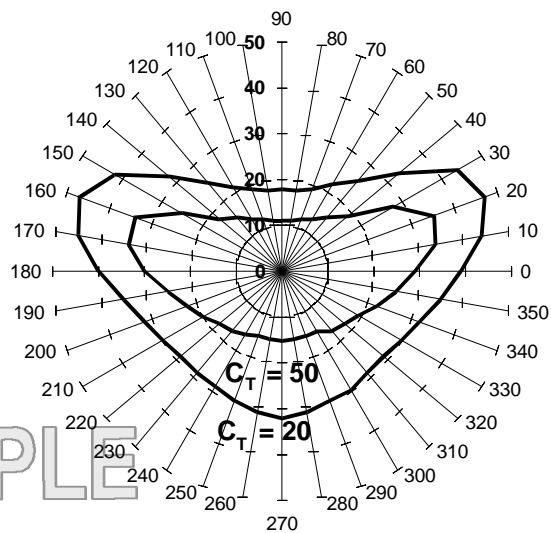


**PROCEDURE:** Make the required goniometric measurements of luminance and chromaticity coordinates of the required full-screen patterns with the luminance or color meter positioned at each of the off-normal viewing angles.

**DATA EXAMPLES:** LEFT—Example of constant luminance threshold set to 50 % degradation relative to perpendicular RIGHT—Example of off-normal angles for specified contrast ratio of full screen white and black for sampled azimuth angles

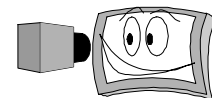


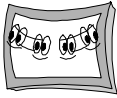
**Fig. 1.** Threshold angles for a 50% decrease in luminance from the full-screen-white-center-perpendicular value.



**Fig. 2.** Threshold angles for contrast degradation to 50:1 and 20:1 from the full-screen-white-center-perpendicular value.

OPTICAL



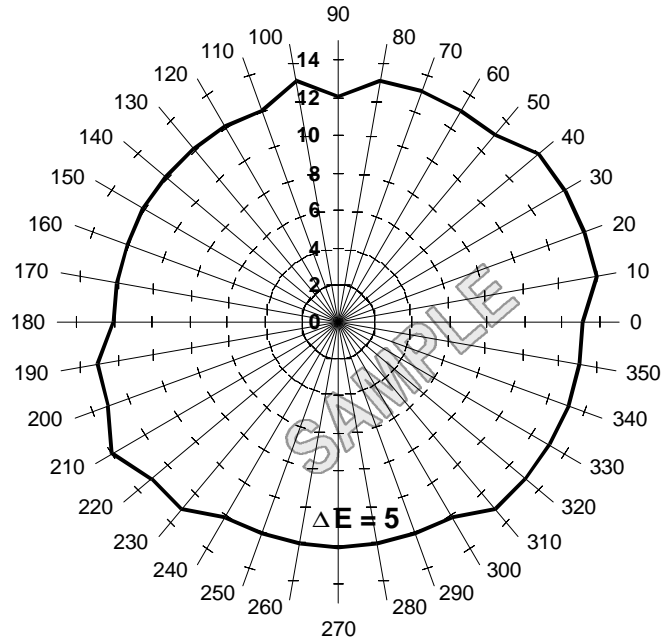


**ANALYSIS:** Provide the required analysis for the data desired. For example, for each white and black screen luminance measurements, compute the contrast ratio of white to black; or calculate the chroma difference values in  $\Delta u'v'$ , or  $\Delta E$  units for each of the CIE  $x, y$  chromaticity coordinates measured on a full white screen using the perpendicular viewing direction as reference. Use linear interpolation to compute the angular viewing directions that correspond to criterion or threshold levels. For example, (1) luminance, such as 50 % from its perpendicular value, (2) contrast ratio, such as  $C_T = 10$  (or other values such as 20, 50, or as previously agreed upon), and (3) color difference such as  $\Delta E = 5$ .

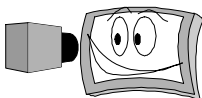
**REPORTING:** Present the interpolated viewing angles at each criterion or threshold values in the form of a polar plot, such as luminance, contrast ratio, and color difference. If data are presented in tabular form, show no more than three significant figures. If a single value for viewing angle is reported, report the minimum (worst case) inclination angle.

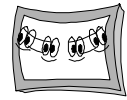
**COMMENTS:** This measurement is a determination of the viewing angles at which arbitrary levels of an optical quantity are determined, e.g., luminance, contrast, and color difference. Since the viewing directions are not limited to those tilted vertically along the y-axis and tilted horizontally along the x-axis of the display, but are obtained through measurement of the full viewing angle cone, the resulting polar representation of the data is considered to be a substantially complete assessment of the display's dependencies on viewing direction. Measurement of color difference of low-luminance black screens is not recommended due to limitations in sensitivity of most color meters (filter colorimeters, spectrometers, and spectroradiometers). Long integration times required to accurately measure color of many low luminance points along the viewing cone is considered impractical.

The 360° polar plots (some call them radar plots) portray the hemisphere in front of the display in a two-dimensional graph. The distance from the center of the graph is the polar angle in spherical coordinates  $q$  and the angle in the clockwise direction is the rotation angle  $f$  from the x-axis in spherical coordinates. In order to properly convert goniometric or viewing angle coordinates to spherical coordinates, see Section 300 for the coordinate transformations.



**Fig. 3.** Angles for a color change of  $\Delta E_{uv}^* = 5$  from the full-screen white center perpendicular value.



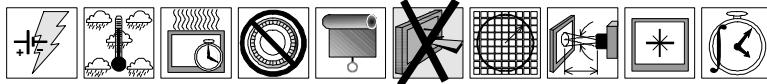


## 307-5 GRAY-SCALE INVERSION VIEWING CONE

**DESCRIPTION:** Full screen contrast ratio measurements are made at the center of the screen for each of 8 gray levels (optionally 16) from many viewing angles to determine at which viewing directions the contrast ratios between adjacent gray levels diminish to one.

**SETUP:** Arrange the luminance meter to measure the luminance of each of eight (optionally 16) full screen gray test patterns from black to white at screen center. There are several ways to obtain the data within the hemisphere in front of the display: (1) Data are measured at five degree intervals of the vertical angle and 10 degree intervals of horizontal angles. (2) Data are measured using spherical coordinates with  $Dq_i = 5^\circ$  and  $Df_i = 360^\circ/m$  for  $12 \leq m \leq 36$ . (3) Data are measured in one shot using a hemispherical LMD. These data are presented in a 360 degree (radar) plot. For cases (1) and (2) use a goniometric positioning device such as a rotating platter or motorized positioning system to assure an accurate angular alignment ( $\pm 1^\circ$ ) between the luminance meter and the screen normal. Optionally, a colorimeter is required for obtaining CIE chromaticity coordinates or correlated color temperature (CCT). See Section 301 for any standard setup details.

**SPECIFIC:** Full screen white, gray levels, and black patterns.



**PROCEDURE:** Make luminance measurements of each full screen gray scale test patterns from white to full black at center screen with the luminance meter positioned at each of the off-normal viewing angles. Incrementally increase,  $5^\circ$  maximum increment size, the off-normal viewing directions to determine the angles of view at which the luminance of the higher gray level,  $n+1$ , equals (and is therefore indistinguishable from) that of the lower gray level,  $n$ . These data are presented in a 360 degree iso-contrast plot. There are several ways to obtain the data within the hemisphere in front of the display: (1) Data are measured at five degree intervals of the vertical angle and 10 degree intervals of horizontal angles. (2) Data are measured using spherical coordinates with  $Dq_i = 5^\circ$  and  $Df_i = 360^\circ/m$  for  $36 \leq m \leq 12$ . (3) Data are measured in one shot using a hemispherical LMD.

**ANALYSIS:** Use linear interpolation to compute the angular viewing directions from measurements that correspond to  $C_T = 1$  for each adjacent gray level pair.

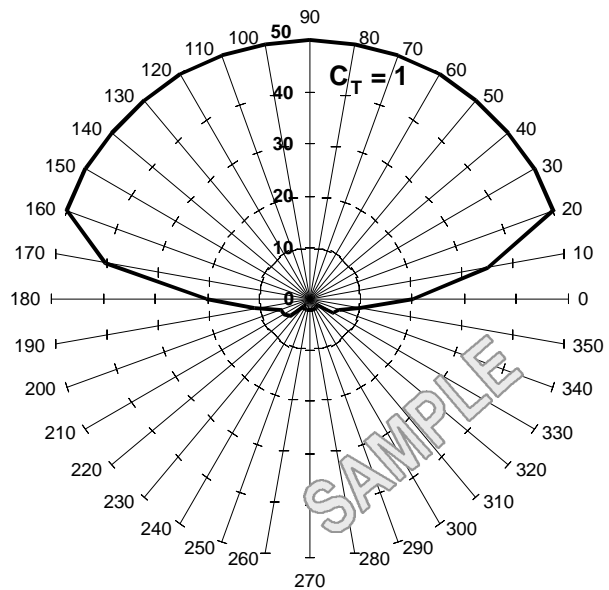
**REPORTING:** Report the viewing angles at which gray scale inversion occurs for each adjacent gray level pair to no more than three significant figures. Also present the viewing angles in the form of a polar plot for adjacent gray-level pairs. Present the data in tabular form to no more than three significant figures.

**COMMENTS:** This measurement is a determination of the viewing angles at which gray scale inversion occurs.

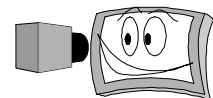
Since the viewing directions are not limited to those tilted vertically along the y-axis and tilted horizontally along the x-axis of the display, but are obtained through measurement of the full viewing angle cone, the resulting isocontrast representation of the data is considered to be a substantially complete assessment of the display gray scale dependencies on viewing direction.

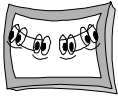
The  $360^\circ$  polar plots (some call them radar plots) portray the hemisphere in front of the display in a two-dimensional graph. The distance from the center of the graph is the polar angle in spherical coordinates  $q$  and the angle in the clockwise direction is the rotation angle  $f$  from the x-axis in spherical coordinates. In order to properly convert goniometric or viewing angle coordinates to spherical coordinates, see Section 300 for the coordinate transformations

**NOTE:** As remarked at the end of the introduction to this section (307), here is how the gray-scale inversion metrics



**Fig. 1.** Off-normal angles for grayscale inversion of a full-screen adjacent gray level pair.





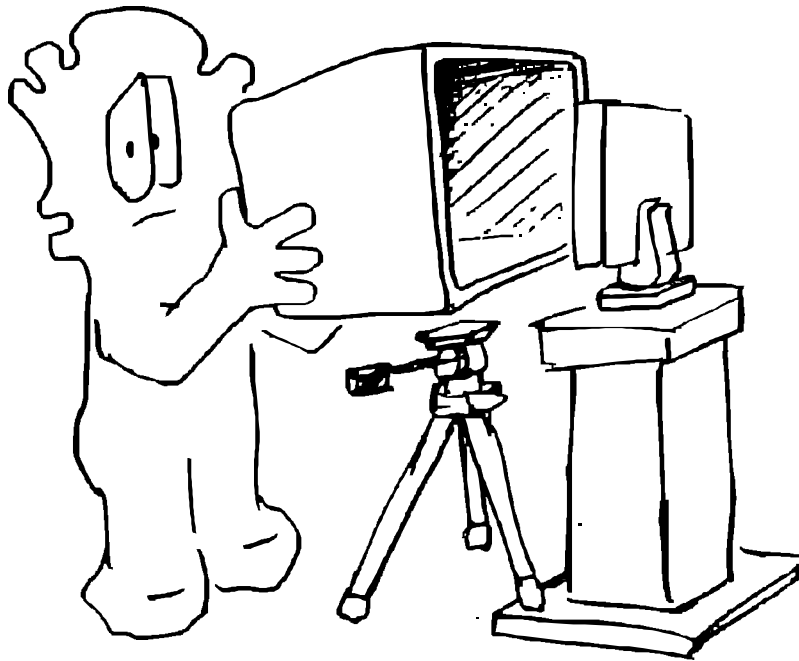
described here and in 307-3 can be extended to color inversions as functions of gray level and angle:

- (1) For a given gray level in all three (red, green, blue) channels, define three adjacent colors as reddish (neutral + 1 level red), greenish (neutral + 1 level green), and bluish (neutral + 1 level blue).
- (2) Measure CIE  $(x, y)$  values for these three colors at any required viewing angle.
- (3) Record whether the ordering of these colors in  $(x, y)$  space is clockwise or counterclockwise, proceeding from reddish (r) to greenish (g) to bluish (b). To do this, compute the quantity

$$P = \text{sgn}(x_g y_b - x_b y_g + x_b y_r - x_r y_b + x_r y_g - x_g y_r),$$

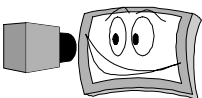
where the function  $\text{sgn}$  evaluates to 1 when its argument is positive, to -1 when its argument is negative, and to 0 when its argument is zero. The ordering from r to g to b is counterclockwise in  $(x, y)$  space when  $P$  is positive, clockwise when  $P$  is negative, and collinear when  $P$  is zero.

- (4) As a function of viewing angle, a color reversal is defined when the computed  $P$  changes its value.



You might be a Rustic if you use a beer cooler as an integrating sphere.

### RUSTIC METROLOGY





## 308 REFLECTION

In this document when we speak of diffuse reflectance we will generally mean a Lambertian reflector; when we speak of specular reflectance we will generally mean a mirror like reflection that produces a distinct virtual image of the source. Reflection characterization is often thought to be straightforwardly based on these simple diffuse and specular models. Such an impression is naive, at best. Diffuse is treated simply as a proportionality between the luminance  $L$  and the illuminance  $E$  by the luminance factor  $r_d$ :

$$L = \frac{r_d}{\pi} E = qE, \quad (1)$$

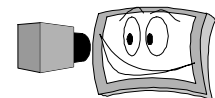
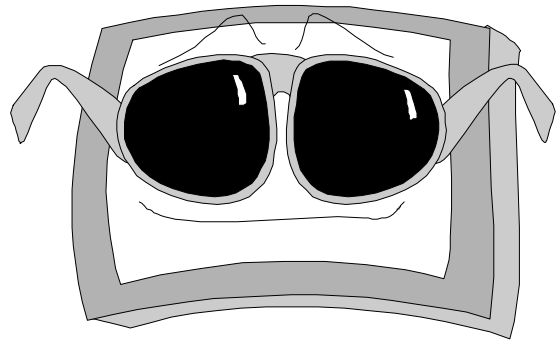
where the luminance coefficient is defined as  $q \equiv r_d/\pi$  (this model is really only for a Lambertian reflector). The specular reflection is characterized by the specular reflectance  $r_s$  where the luminance  $L$  is related to the source luminance  $L_s$  via

$$L = r_s L_s. \quad (2)$$

If the non-specular component of reflection were so trivial it would be a simple matter to measure such coefficients and these simple models would permit the straightforward calculation of the reflected luminance of the screen in any lighting environment. However, in reality, a diffuse (Lambertian) and specular (mirror-like) model is often an inadequate description because there is a third component of the reflection which we will call haze. Haze is that fuzzy ball of light around the specular image or that smeared-out fuzzy luminance seen in the specular direction in which there can be no distinct specular image. The proper treatment of haze, and reflection in general, requires the use of the concept and measurement of the bidirectional reflectance distribution function (BRDF). See the section Reflection Models (A217) for more details. Only then is the reflection properly characterized, and only then can a reflection model be developed which will provide the correct calculated reflected luminance from the screen in any lighting environment. Much of the trouble in the past with attempting to characterize reflection for displays has arisen from a failure to recognize and properly treat the haze component.

There can be display surfaces that measure the same specular and diffuse reflectance (using simple measurement techniques) that look entirely different to the eye—all because of the haze component. Some displays have all three components. Many FPDs being produced have essentially only a nontrivial haze component—you can't see an image of the source, but there is a fuzzy patch of light in the specular direction of the source. A piece of copy paper is a display that essentially only has a diffuse (Lambertian) component. Many televisions have a specular component (with distinct virtual image) and a diffuse component with the haze component almost nonexistent.

Many screen treatments today offer an etching of the glass or some treatment of the screen cover material that reduces the specular component by the introduction of haze. That is, they spread the energy from the strictly specular virtual-image-producing direction into other directions, mostly near the specular direction. The diffuse component is proportional to the illuminance, the specular component is proportional to the luminance of the source, but the haze component is proportional to the illuminance and peaked in the specular direction. The complications arising from haze renders the simple measurement methods somewhat ineffective and definitely irreproducible. One way to deal with haze simply, without resorting to BRDF measurements, is to place the DUT inside an integrating sphere. Few have the money or room for the large integrating sphere that would be required. So, in order to accommodate some kind of reproducible reflection measurement we have provided two measurements that employ a hemispherical surround (or equivalent) that can be placed over the screen. These hemispherical surrounds can be constructed in many different ways yet yield fairly reproducible results. See 308-1 Total Reflection with Diffuse Illumination and 308-2 Ambient Contrast Ratio for examples of the measurements using an integrating sphere (or equivalent). We have also included some of the more common measurement method for reflection characterization as found in ISO 9241-7, with cautions for FPD applications. [3]





For many types of FPD technologies the front surface of the display can be placed very close to the pixel surface. This offers an advantage over thick or separated covering surfaces in that the specular component of reflection can be eliminated entirely by using a diffusing front surface. Such a diffusing surface cannot be used when it is displaced too far from the pixel surface. Adding a multi-layer antireflection coating to such a diffusing surface can create a screen that is very dark in appearance even in bright lighting. Such screens have essentially only a haze component of reflection.

**Illumination Sources:** When measuring reflected luminance using different types of ambient light, there are three characteristics of the lighting that need consideration: the **temporal modulation** (as when driven by an ac source), the **spectral composition** of the illumination, and the **uniformity** of the illuminating surface of the source. If the light employed exhibits ac modulation, the luminance may be found to be unstable depending upon the depth of the modulation and the integration time of the LMD. The integration time can be extended with the careful use of neutral density filters, see A102 Spatial Invariance and Integration Times in the Metrology Section for details. The spectral content can be a problem since multilayer antireflection coatings are used—you won't get the same reflectance using a fluorescent lamp as you would a tungsten-halogen lamp. Many of these multilayer antireflection coatings have a color to them, often magenta, because they are deliberately adjusted to reduce the green components of reflection to which the eye is most sensitive. One of the most reliable illuminants used to date is the tungsten halogen source used with dc power at a CCT of 2856 K (CIE standard illuminant A). Such a source is recommended for reflection measurements in general, but especially when color is involved. Any other type of lighting should be noted and reported clearly on any data sheet. The uniformity of the surface can be important especially when the haze component of reflection is complicating the situation.

**Note:** These measurements are not intended to deal with special or strange reflection properties such as narrow-band reflection surfaces, retroreflection, or strongly colored reflection. Special reflection properties such as these can be addressed using the ASTM Standards on Color and Appearance. [13]

#### **308-1 REFLECTANCE WITH DIFFUSE ILLUMINATION**

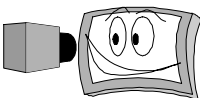
#### **308-2 AMBIENT CONTRAST RATIO**

#### **308-3 LARGE-SOURCE DIFFUSE REFLECTANCE**

#### **308-4 LARGE-SOURCE SPECULAR REFLECTANCE**

#### **308-5 SMALL-SOURCE SPECULAR REFLECTANCE**

See **A217 REFLECTION MODELS** for more information.





## 308-1 REFLECTANCE WITH DIFFUSE ILLUMINATION

### (directed hemispherical reflectance)

**DESCRIPTION:** With the DUT off (assumed to be its darkest state), the reflectance (directed hemispherical reflectance [DHR]) arising from uniform diffuse illumination is measured and expressed as a fraction of the reflectance from a perfect white diffuse reflector. **Units:** none.

**Symbol:**  $r_H$ .

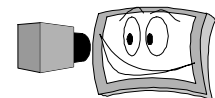
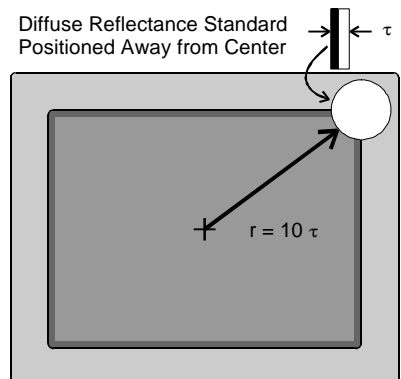
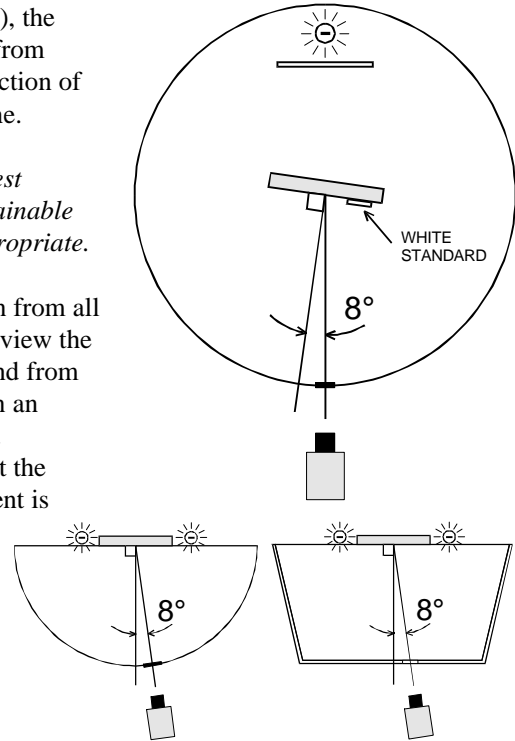
**NOTE:** If the powered-off state of the DUT is not the darkest condition of the DUT screen and the darkest screen is only obtainable with the DUT being powered, then this measurement is not appropriate. Perform the Ambient Contrast (308-2) measurement instead.

**SETUP:** A diffuse-ambient light is provided to illuminate the screen from all directions as uniformly as is practical. The LMD is arranged to view the center of the surface of the display through a hole in the surround from an angle of  $8^\circ$  ( $-0^\circ+2^\circ$ ) from the normal (or rotate the display in an integrating sphere). The LMD is focused on the display surface.

We show  $8^\circ$  here as probably the safest angle to use so that the measurement hole won't affect the reflection yet the measurement is made as close to the normal of the screen as possible. See the Comments for more discussion.

**Surround:** Ideally, an integrating sphere is best. However, it may be possible to use a surround that is less than perfect. The success of using surrounds other than an integrating sphere depends upon how uniform the illumination is from all directions in front of the display. A white hemisphere that is evenly illuminated is preferred if an adequate integrating sphere is not available. If that is not possible, a box can be constructed and painted with the whitest matte paint available. A number of configurations can be used (even a hemisphere or integrating-sphere device smaller than the screen height or width), but it is most important that the surround have a relatively uniform luminance distribution over the part of the surround that is in the vicinity ( $\pm 30^\circ$ ) of the perpendicular of the display surface—see the Metrology Appendix, Auxiliary Laboratory Equipment (A113). The hole diameter should be larger than the diameter of the lens of the LMD—the entrance pupil of the LMD—from 20 % to 30 % larger. However, care must be exercised to avoid any direct light from the sources or any bright reflections off any surface (other than the screen itself) from hitting the lens of the LMD in order to minimize veiling glare contamination of the reflected luminance measurement. Since the hole is larger than the lens, the LMD should be moved back from the hole so that only a fraction of the screen is visible to the LMD. This will assure that there is no veiling-glare corruption in the measurement. Watch out for reflections off the inside diameter of the hole also contributing to glare corruption. The hole may have to be beveled away from the lens. In the future there may be LMDs available that provide the capability to make these measurements without the necessity of a surround by using a small integrating sphere to sample the surface. Such devices are under study at the time of this writing.

**White Standard:** A diffuse white reflectance standard of known luminance factor  $r_{std}$  is required if the illuminance on the screen cannot be measured directly with an illuminance meter. If you want to make two measurements one with and one without the reflectance standard, then the white standard would be positioned at the center of the screen for the measurement of the standard. However, if you want to make both the measurement of the reflection of the screen and the diffuse standard at roughly the same time, then the white standard should be placed as close as possible to the center of the screen without affecting

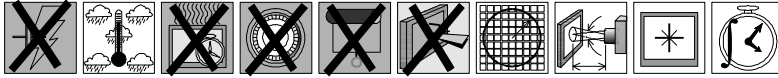




the measured screen reflection (a minimum distance of 8 to 12 times the thickness of the white standard is reasonable—the thickness in the direction of the screen normal). The white standard, if used, should be placed near the display surface during the measurements with the surround in place. Be careful not to touch the display surface if it is delicate.

**Lamps:** If an integrating sphere cannot be used, the lamps should be behind the plane of the surface of the display near the display, but not too near so that they heat up the display. They should be moved to provide the most uniform illumination of the surround especially in front of the display. When adjusting their placement, keep in mind that your clothing may contribute to some of the light. We suggest that the illuminance on the screen be at least 200 lx.

**SPECIFIC:** Alternate full-screen white and black. See Section 301 for any standard setup details.



**PROCEDURE:** Measure the luminance  $L$  of the center of the screen with the DUT off (unpowered or darkest black). Then place a white diffuse standard of known reflectance  $r_{\text{std}}$  at the position of screen center and measure its luminance  $L_{\text{std}}$ . Be careful not to touch the surface of the screen unless the screen is made for rough handling.

**ANALYSIS:** Calculate the total reflectance with diffuse illumination (DHR):  $r_{\text{H}} = r_{\text{std}} L / L_{\text{std}}$

**REPORTING:** Report the total reflectance with diffuse illumination (DHR) to no more than three significant figures.

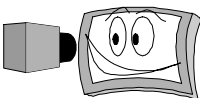
**COMMENTS:** Tungsten and fluorescent ac-powered lamps may exhibit an ac fluctuation which can increase the imprecision of the measurements. See the Metrology Section on Auxiliary Laboratory Equipment (A113) for more details on making or obtaining a white diffuse standard.

Clearly, this is not a correct model for reflection. We are treating the display as if it were a diffuse Lambertian reflector, for we are comparing it to a diffuse Lambertian reflectance. There are many surface treatments, and many displays that are not diffuse (Lambertian), but have a specular and a haze component of reflection. Having addressed all the objections, the reflectance from diffuse illumination is a convenient single parameter that characterizes the reflectivity of a display, and is fairly reproducible with a wide variety of apparatus.

The use of the  $8^\circ$  ( $-0, +2^\circ$ ) angle can be important depending upon the reflectance properties of the display and the uniformity of the illuminating surface. Ideally, we would want to be infinitesimally small and located along the perpendicular of the center of the screen in order to make this measurement perfectly. Since our LMD has a finite size, we cannot measure along the perpendicular because the reflection of the LMD would interfere with the reflection (unless the screen were truly Lambertian). The problem with this measurement arises because of the haze term. If the display reflection were characterized by only Lambertian and (distinct-image) specular reflections (no haze), then simpler measurements could be used to characterize reflections. So, what angle do we want? We want to use an angle that is as close to the perpendicular as possible but that won't interfere with the measurement of the reflection. If we go too far, like  $20^\circ$  or more, then a good portion of the light hitting the display relative to our  $20^\circ$  viewpoint comes from angles greater than  $90^\circ$ , and that is not representative of someone sitting in front of the display. Because of the haze, an error can be introduced in the measurement. Conversely, if we use less than  $8^\circ$  to  $10^\circ$ , then we might find that the hole through which we measure is starting to affect the measurement, again, because of the haze reflection. In many cases  $5^\circ$  would probably work just as well— $8^\circ$  is safe.

The error in this measurement comes primarily from the error in the measured luminance of the screen  $L$ . Not that the LMD is in error but that unless an integrating sphere is used (carefully), the nonuniformity of the illumination can cause difficulties. If a hemisphere (or equivalent) is used, it can be a challenge to get that hemisphere evenly illuminated. How well this method works depends upon the reflectance properties of the screen—and haze introduces much of the error—so that we can anticipate a measurement of the reflectance  $r_{\text{H}}$  will exhibit a reproducibility of  $\pm 5\%$  at best.

Analysis and Reporting (Sample Data)	
Measure $L$ ( $\text{cd}/\text{m}^2$ )	32
Measure $L_{\text{std}}$ ( $\text{cd}/\text{m}^2$ )	117
$r_{\text{std}}$ (known)	0.97
DHR, $r_{\text{H}}$ $r_{\text{H}} = r_{\text{std}} L / L_{\text{std}}$	0.27





## 308-2 AMBIENT CONTRAST RATIO



**DESCRIPTION:** We measure the contrast ratio at center screen using full-screen black and full-screen white under diffuse-ambient lighting conditions. The measurement is adjusted to give the reflection performance under the desired task ambient illumination (typically for offices, 500 lx). **Units:** none, a ratio. **Symbol:**  $C_A$ .

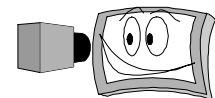
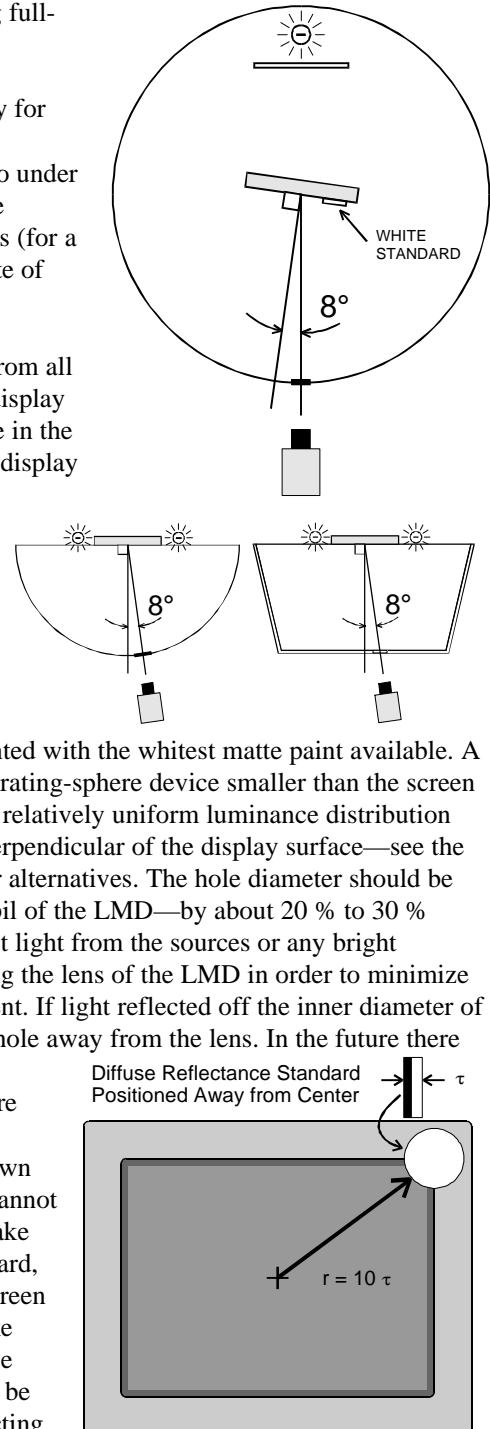
The measurement of the full-screen black-white contrast ratio under ambient lighting conditions is a measure of the performance of the display with illumination similar to the required task environments (for a bright office we use 500 lx maximum). Note: For use with the Suite of Basic Measurements (SBM), the results must be adjusted for an illuminance of  $E_L = 500$  lx.

**SETUP:** A diffuse-ambient light is provided to illuminate the screen from all directions as uniformly as is practical. The LMD, focused on the display surface, is arranged to view the center of the screen through a hole in the surround from an angle of  $8^\circ (\pm 2^\circ)$  from the normal (or rotate the display in an integrating sphere).

**Surround:** Ideally, an integrating sphere is best. However, it may be possible to use a surround that is less than perfect. The success of using surrounds other than an integrating sphere depends upon how uniform the illumination is from all directions in front of the display as well as the reflectance properties of the display. A white hemisphere that is evenly illuminated is preferred if an adequate integrating sphere is not available. If that is not possible, a box can be constructed and painted with the whitest matte paint available. A number of configurations can be used (even a hemisphere or integrating-sphere device smaller than the screen height or width), but it is most important that the surround have a relatively uniform luminance distribution over the part of the surround that is in the vicinity ( $\pm 30^\circ$ ) of the perpendicular of the display surface—see the Metrology Appendix, Auxiliary Laboratory Equipment (A113) for alternatives. The hole diameter should be larger than the diameter of the lens of the LMD—the entrance pupil of the LMD—by about 20 % to 30 % larger at least. However, care must be exercised to avoid any direct light from the sources or any bright reflections off any surface (other than the screen itself) from hitting the lens of the LMD in order to minimize veiling glare contamination of the reflected luminance measurement. If light reflected off the inner diameter of the hole might cause glare corruption, you may want to bevel the hole away from the lens. In the future there may be LMDs available that provide the capability to make these measurements without the necessity of a surround. Such devices are under study at the time of this writing.

**White Standard:** A diffuse white reflectance standard of known luminance factor  $r_{std}$  is required if the illuminance on the screen cannot be measured directly with an illuminance meter. If you want to make two measurements one with and one without the reflectance standard, then the white standard would be positioned at the center of the screen for the measurement of the standard. However, if you want to make both the measurement of the reflection of the screen and the diffuse standard at roughly the same time, then the white standard should be placed as close as possible to the center of the screen without affecting the measured screen reflection (a minimum distance of 8 to 12 times the thickness of the white standard is reasonable—the thickness in the direction of the screen normal). The white standard, if used, should be placed near the display surface during the measurements with the surround in place. Be careful not to touch the display surface if it is delicate.

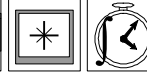
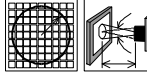
**Lamps:** If an integrating sphere cannot be used, the lamps should be behind the plane of the surface of the display near the display, but not too near so that they heat up the display. They should be moved to provide the



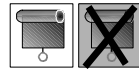


most uniform illumination of the surround. When adjusting their placement, keep in mind that your clothing may contribute to some of the light. We suggest that the illuminance on the screen be at least 200 lx.

**SPECIFIC:** Alternate full-screen white and black. See Section 301 for any standard setup details.



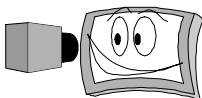
Both darkroom and non-darkroom conditions are used.



**PROCEDURE:** (1) Under darkroom conditions without the surround in place (remove the reflection surround if it is in front of the screen, or move the display to another darkroom location) measure the center screen white  $L_w$  and black  $L_b$  luminances. (2) Install the surround and measure the self luminance of the screen because of its light reflecting back off the surround. Do this for both black and white full screens  $L'_w, L'_b$ . (3) Now illuminate the reflective surround. (3a) Measure the illuminance  $E$  on the surface of the DUT center using an illuminance meter or (3b) measure the luminance  $L_{std}$  of the white standard near center screen. The illuminance is given by  $E = \pi L_{std} / r_{std}$ . Be careful not to touch the surface of the screen unless the screen is made for rough handling. (3c) Measure the luminance of the full-screen black  $L_{ab}$  and full-screen white  $L_{aw}$  under conditions of ambient reflection.

**ANALYSIS:** (1) First, calculate the net self luminance for the black and white screens with the surround in place, but not illuminated with anything but the light from the display. The self luminance contributions are:  $L_{sw} = L'_w - L_w$  for white and  $L_{sb} = L'_b - L_b$  for black. (2) Calculate the net reflected luminance (only the reflected light, not the light originating from the screen or any self luminance of the screen) for white  $L_{rw} = L_{aw} - L_w - L_{sw}$  and for black  $L_{rb} = L_{ab} - L_b - L_{sb}$ ; it is very likely that  $L_{rw}$  and  $L_{rb}$  will be approximately the same magnitude. (3) Calculate the correction factor  $k = E_L / E$ , where  $E_L$  is the adjusted illuminance value (500 lx is typical for a bright office environment). Note: For use with the SBM,  $E_L = 500$  lx must be used. (4) Calculate the luminances that would be obtained using an  $E_L$  illuminance:  $L_{AW} = L_w + kL_{rw}$  and  $L_{AB} = L_b + kL_{rb}$ . (5) The ambient contrast ratio corrected for the adjusted illumination of  $E_L$  is then given by:  $C_A = L_{AW} / L_{AB}$ . A summary of these equations follow:

Summary of Ambient Contrast Measurement							
Equations	Symbol	Description	Known	Darkroom	Surround	Ambient on	Calculated
<b>1. DARKROOM MEASUREMENTS:</b>							
	$L_w$	luminance of full white screen in darkroom		■			
	$L_b$	luminance of full black screen in darkroom		■			
<b>2. INSTALL SURROUND WITH LIGHTS OFF (ONLY LIGHT FROM SCREEN PRESENT):</b>							
	$L'_w$	screen white plus self luminance from surround			■		
	$L'_b$	screen black plus self luminance from surround			■		
$L_{sw} = L'_w - L_w$	$L_{sw}$	net self white luminance					■
$L_{sb} = L'_b - L_b$	$L_{sb}$	net self black luminance					■
<b>3. ILLUMINATE SURROUND TO PROVIDE AMBIENT ILLUMINATION:</b>							
	$L_{aw}$	luminance of white screen with ambient on				■	
	$L_{ab}$	luminance of black screen with ambient on				■	
$L_{rw} = L_{aw} - L_w - L_{sw}$	$L_{rw}$	net reflected luminance from white screen					■
$L_{rb} = L_{ab} - L_b - L_{sb}$	$L_{rb}$	net reflected luminance from black screen					■
	$L_{std}$	luminance of white standard					■
	$r_{std}$	reflectance of white standard		■			
$E = \pi L_{std} / r_{std}$	$E$	incident illuminance (measure or calculate)					■
	$E_L$	adjusted illuminance value (500 lx typically)		■			
$k = E_L / E$	$k$	adjustment factor for illuminance of $E_L$					■
$L_{AW} = L_w + kL_{rw}$	$L_{AW}$	ambient adjusted white luminance					■
$L_{AB} = L_b + kL_{rb}$	$L_{AB}$	ambient adjusted black luminance					■
$C_A = L_{AW} / L_{AB}$	$C_A$	ambient contrast					■





**REPORTING:** Report the black and white adjusted luminances with reflection for a 500 lx illumination  $L_{AW}$ ,  $L_{AB}$  and the ambient contrast ratio  $C_A$  to no more than three significant figures. Report the adjusted illuminance value  $E_L$  if it is not 500 lx. If  $E_L$  is not explicitly reported it must be 500 lx.

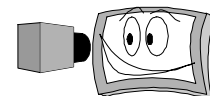
**COMMENTS:** Tungsten and fluorescent ac-powered lamps may exhibit an ac fluctuation which can increase the imprecision of the measurements. In the event that an illuminance meter is not available, the illuminance can be determined with the aid of a white diffuse standard having a known luminance factor  $r_{std}$ . Measure the luminance  $L_{std}$  of the standard at the position of the screen, the illuminance is given by  $E = L_{std} \pi / r_{std}$ . See the Metrology Section on Auxiliary Laboratory Equipment (701-13) for more details on making or obtaining a white diffuse standard. The value of the adjusted illuminance  $E_L = 500$  lx arises from a conventional ergonomic representation of office lighting where it is assumed the illuminance on a display is given by  $E = E_0 (1 + \cos\alpha)$ , where  $E_0 = 250$  lx and  $\alpha$  is the angle of the surface of the display and the horizontal plane ( $\alpha = 90^\circ$  for a vertical display surface). The worst case is for the screen lying flat for which  $E = 500$  lx. Other adjusted illuminance values may be used provided all interested parties agree.

There may be devices that are very different from the apparatus described above and that provide a measurement of the total reflectance with diffuse illumination (DHR) and the ambient contrast. Some LMDs are specially developed to make this kind of a measurement. They measure the reflection properties of a small area on the screen. Their use is under study at the time of this writing.

It is instructive to compare this ambient contrast ratio with the full-screen contrast ratio (see 302-3, Contrast Ratio of Full Screen, if necessary) obtained from  $C_R = L_w / L_b$ . Because of reflections, a screen that may look good in a dark room with a contrast of 200:1 can be rendered rather unimpressive with a contrast of only 3:1 in a well-lit room.

Reporting - Sample Data	
Ambient Illuminance $E_L$ (lx)	500
White $L_{AW}$ (cd/m <sup>2</sup> )	196
Black $L_{AB}$ (cd/m <sup>2</sup> )	94
$C_A$	2.09

Analysis - Sample Data	
Meas. $L_w$ (cd/m <sup>2</sup> )	105
Meas. $L_b$ (cd/m <sup>2</sup> )	0.512
Meas. $L'_w$ (cd/m <sup>2</sup> )	112
Meas. $L'_b$ (cd/m <sup>2</sup> )	3.21
Calc. $L_{sw}$ (cd/m <sup>2</sup> )	7
Calc. $L_{sw}$ (cd/m <sup>2</sup> )	2.70
Meas. $L_{aw}$ (cd/m <sup>2</sup> )	180
Meas. $L_{ab}$ (cd/m <sup>2</sup> )	67.9
Calc. $L_{tw}$ (cd/m <sup>2</sup> )	68.3
Calc. $L_{tb}$ (cd/m <sup>2</sup> )	64.7
Meas. * $L_{std}$ (cd/m <sup>2</sup> )	63.25
$r_{std}$ *	0.96
Adjusted for Ambient Illuminance $E_L$ (lx)	500
Calculate * or Meas. $E = L_{std} \pi / r_{std}$ (lx)	207
Calc. $k$	1.4493
Calc. $L_{AW}$ (cd/m <sup>2</sup> )	196
Calc. $L_{AB}$ (cd/m <sup>2</sup> )	94
Calc. $C_A$	2.09
Compare: $C_R = L_w / L_b$	205
* Not needed if $E$ measured directly	





## 308-3 LARGE-SOURCE DIFFUSE REFLECTANCE

### extended-source diffuse reflectance

**WARNING:** The correct measurement of this reflectance assumes that the display surface exhibits a quasi Lambertian diffuse reflectance away from the specular direction. If this is the case, the illuminance and luminance are related by  $L = qE$ , and  $q = r_d / p$ , where  $r_d$  is the luminance factor. Applying this measurement to materials that have gain (i.e., exhibit a haze component of reflection and are non-Lambertian) is, strictly speaking, incorrect. Not only are the results not simply interpreted by the true Lambertian reflectance model,  $L = qE$ , but the measurement may be subject to many errors from alignment of the components of the apparatus, the placement of the devices, and the characteristics of the devices. Employing this diffuse reflectance measurement for surfaces that have a significant haze reflection component can create irreproducible results. All interested parties should be cognizant of any misapplication of this measurement. See A217 BRDF Reflectance Model for further discussion of the components of reflection.

**DESCRIPTION:** With the DUT off (assumed to be its darkest state), the diffuse (Lambertian) reflectance is measured. **Units:** none. **Symbol:**  $r_d$ .

**NOTE:** If the powered-off state of the DUT is not the darkest condition of the DUT screen and the darkest screen is only obtainable with the DUT being powered, then this measurement may not be appropriate. In such cases be sure that all interested parties are in agreement in their expectations.

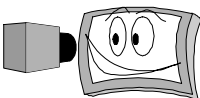
**SETUP:** Two light sources (lamps) and a diffuse white reflectance standard are needed.

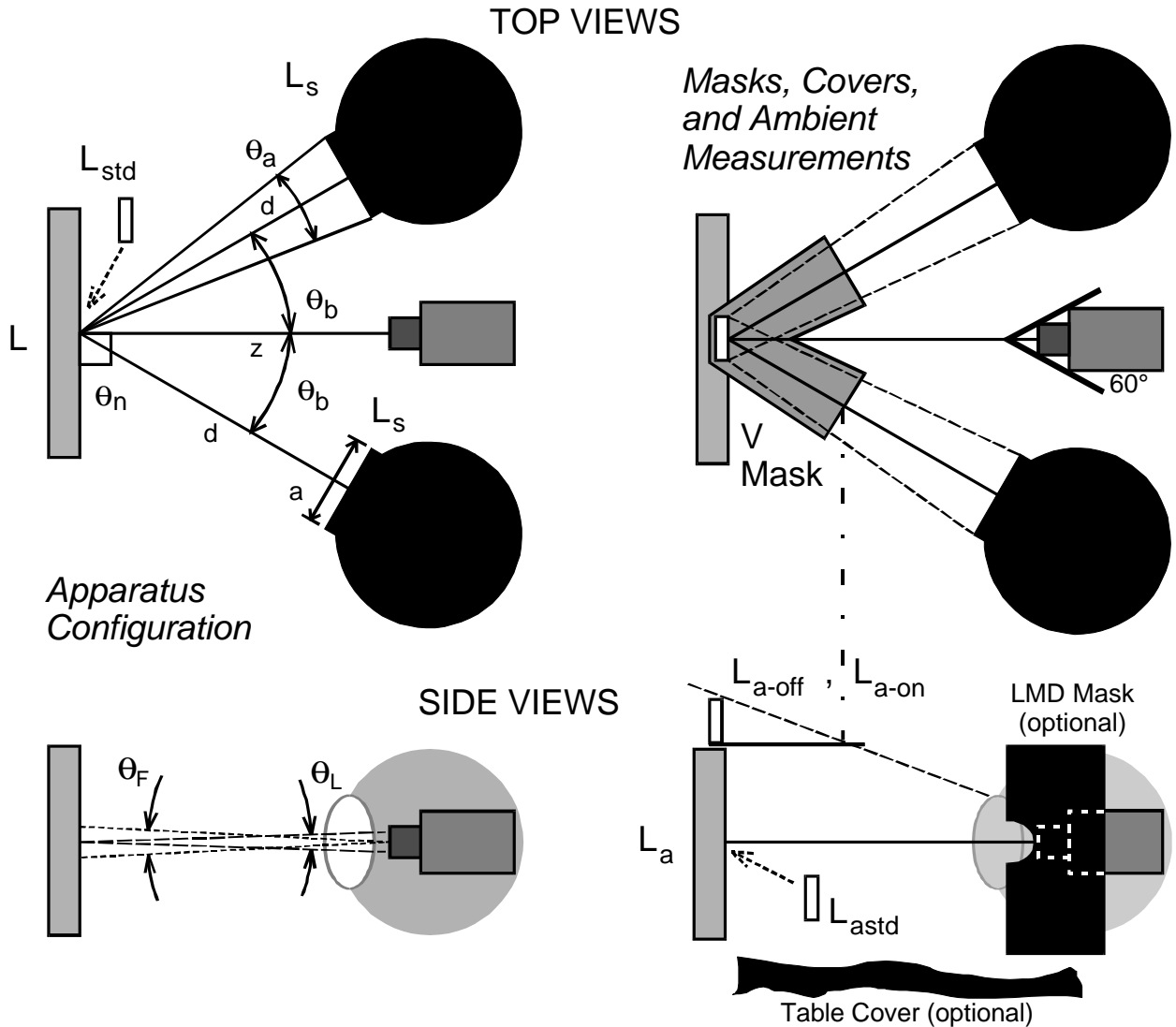
**NOTE:** The specifications made upon the apparatus and the configuration presented below is especially important when the haze component of reflection is significant. If there is only a specular (mirror like) and diffuse (Lambertian) component of reflection (i.e., the haze component is trivial), then all these constraints become much less important, e.g., the diffuse reflectance should be independent of the angles from the normal, sizes, and distances of the lamps (if the surface is truly Lambertian) for a wide range of angles, sizes, and distances. To accommodate these two possibilities, two specifications are offered: one for no haze component and one for a non-trivial haze component. The tightening of the specifications is required whenever the haze component is significant in order to assure reproducibility of the measurement. How closely these tolerances are met will determine how reproducible the measurement is. The tolerances should be adequate to provide a  $\pm 5\%$  reproducibility of the diffuse reflectance measurement result.

**WHITE STANDARD:** A diffuse white reflectance standard of known luminance factor  $r_{std}$  is required. When positioning the white standard be careful not to touch the display surface if it is delicate.

**LAMPS AND LMD:** Two lamps are placed  $\pm 30^\circ$  ( $\pm q_s$ ) on each side of normal having round exit ports of 150 mm in diameter. The distance between the center of the exit port and the center of the screen is  $d$  (nominally 500 mm). The nonuniformity  $N = 1 - L_{min}/L_{max}$  over the exit ports as well as the tolerance of the other parameters in the configuration depend upon the reflection properties of the screen. Table 1 lists the tolerances for the extreme conditions. The LMD should be placed far enough away from the screen that its surfaces are not directly illuminated by the lamps. A lamp luminance  $L_s$  of 2000 cd/m<sup>2</sup> is preferred. The lamps should exhibit a  $\pm 1\%$  or smaller stability during the course of the measurements. The LMD is placed along the normal a distance  $z$  (nominally 500 mm) away from the center of the screen. The figure shows top and side views of a horizontal configuration; a vertically oriented configuration is sometimes employed equivalently, in which case they would be side and top views respectively.

**AMBIENT LIGHT:** Darkroom conditions should be maintained if at all possible, when ambient light is involved, the measurement is subject to increased uncertainties. However, there are some cases where there is no recourse but to measure with some ambient light. In fact, unless many precautions are taken even in a darkroom there can be complications arising from ambient light. There are two sources of ambient light: (1) sources of light in the room other than the lamps along with reflections off of surfaces in the environment that can include the LMD and any other object in close proximity or in front of the display surface, and (2) the additional illuminance from the reflectance of objects in the surrounding environment when the lamps are turned on. Of course, we would prefer that the ambient luminance be less than on half the luminance values obtained when the lamps are turned on. If so, it may be possible to successfully correct for ambient light.

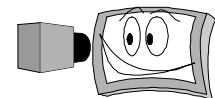




OPTICAL

However, whenever there is a significant haze component, it is important to be careful in minimizing the sources of ambient light. The luminances  $L_a$  and  $L_{std}$  are the luminances of center screen and the diffuse white standard at the center screen with the lamps off. The increase in illuminance from back reflections of the lamp light onto the screen from surrounding objects when the lamps are turned on can be monitored by the change in the ambient luminance of a diffuse white standard with lamps on and then off. The standard is mounted just above the screen and placed in the shadow of a v-shaped mask that prevents direct rays from the lamps illuminating the standard (see description below). When the difference between the lamp-on and lamp-off luminances of the standard ( $L_{a-on}$  and  $L_{a-off}$ ) are small, then the surrounding objects may not be reflecting too much of the lamp light back onto the screen. The amount of back reflection can be regulated to some extent using a LMD mask and a table cover—both described below. Even if the lamp on-off luminances ( $L_{a-on}$  and  $L_{a-off}$ ) are small, the light reflected back from the LMD can be corrupting the measurement since it resides on the normal of the surface where the sensitivity to reflections can be great. Whenever there is a significant haze component, it is important that the reflections from objects near the normal not influence the measurement. This can be checked by measuring the screen luminance (not the luminance of the standard) with the objects covered and then not covered. If the difference between the two luminance values is significantly larger than the repeatability of the LMD then the object should be covered.

**V-Mask:** In the apparatus figure a v-shaped mask is shown on the right side of the figure. The mask should be a medium gray having a diffuse reflectance of between 15 % and 30 % (common gray cardboard should be adequate). This mask is used with the diffuse white standard placed at the top of the display. The



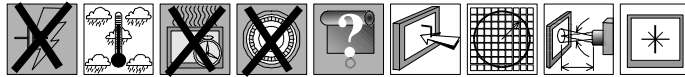


mask shields the standard from the direct rays from the lamps. The measurement of the luminance of the standard provides a means of estimating the amount of light that is reflected back onto the display from the surround when the lamps are turned on.  $L_{a-on}$  and  $L_{a-off}$  are the luminances of the diffuse white standard above the screen (using the mask) with the lamps on and then off.

**LMD-Mask:** If the LMD or objects near it (such as a white shirt of an operator) become illuminated by the lamps either directly or indirectly they can contribute to the measured reflected luminance of the display in ways that cannot be readily determined. Should that be a problem it may be necessary to place black felt over the offending surfaces or place a folded gloss-black sheet of plastic with a hole in the fold for the LMD lens. The angle between the folded surfaces should be about  $60^\circ$  so that the mask doesn't reflect light from the lamps onto the screen because of its gloss-black surface. **NOTE:** Reflections off of the LMD and its support structure when the lamps are turned on can be a problem even in a darkroom.

**Table Cover:** If the measurement is done with the components mounted on a table or other nearby structure, then reflections of the lamps off the surface off the table (or any other component in the vicinity) should be minimized by covering the surfaces exposed to the screen with black felt. **NOTE:** Reflections off of nearby surfaces when the lamps are turned on can be a problem even in a darkroom.

**GENERAL SETUP CONDITIONS:** Display off in black state. See Section 301 for any standard setup details.

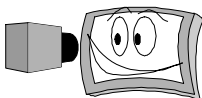


OPTICAL

**Table 1.** Diffuse Reflectance Measurement Specifications \*

Symbol	Description	No Haze	Significant Haze
$L$	Luminance of screen, lamps on	measured	
$L_{std}$	Luminance of diffuse white standard, lamps on	measured	
$q_n$	Angle of LMD relative to normal	$90^\circ \pm 5^\circ$	$90^\circ \pm 0.3^\circ$
$q_a$	Angle subtended by exit port of lamp	$15^\circ \pm 5^\circ$	$15^\circ \pm 0.3^\circ$
$q_b$	Angle of lamp center from normal	$30^\circ \pm 5^\circ$	$30^\circ \pm 0.3^\circ$
$a$	Diameter of exit port of lamp	not critical	$(150 \pm 2)$ mm
$z$	Distance between LMD and screen center	$\geq 500$ mm	$\geq 500$ mm
$d$	Distance between lamp centers and screen	$(500 \pm 50)$ mm	$(570 \pm 5)$ mm
$q_F$	Angular field of view of LMD ( $\infty$ focus)	$\leq 5^\circ$	$\leq 1^\circ$
$q_L$	Angle subtended by LMD lens (entrance pupil)	$\leq 5^\circ$	$\leq 1^\circ$
$L_a$	Ambient luminance of screen, lamps off	measured	
$L_{astd}$	Ambient luminance of diffuse white standard, lamps off	measured	
$L_{a-on}$	Ambient luminance of diffuse white standard place above FPD, v-mask in place, lamps on	measured	
$L_{a-off}$	Ambient luminance of diffuse white standard place above FPD, v-mask in place, lamps off	measured	
$r_d = r_{std} L/L_{std}$	Luminance factor without ambient light corruption	calculated	
$r_d = r_{std} \left( \frac{L - L_a}{L_{std} - L_{astd}} \right)$	Luminance factor with ambient light correction	calculated	
$q = r_d / p$	Luminance coefficient	calculated	
$N$	Nonuniformity of exit port of lamps ( $1 - L_{min}/L_{max}$ )	$\leq 50\%$	$\leq 5\%$
$L_s$	Luminance of lamps (not specifically measured in this procedure)	$\geq 2000$ cd/m <sup>2</sup> preferred Stability: $\pm 1\%$ during measurement	

\* Note: Any deviations from these specifications must be clearly noted, clearly reported, and understood by all interested parties. Sometimes different angles between the sources and the normal may be specified, for example. For comparison purposes it is suggested that the above specifications be maintained.





**PROCEDURE:** Measure the luminance  $L$  of the center of the screen with the DUT off (unpowered or darkest black). Then place a white diffuse standard of known reflectance  $r_{std}$  at the position of screen center and measure its luminance  $L_{std}$ . Be careful not to touch the surface of the screen unless the screen is made for rough handling and is not delicate.

**Accounting for the Effects of Ambient Light:** If you must contend with non-darkroom conditions, it may be possible to correct for the effects of ambient light. There are two possible sources. The ambient room light and the increase in the ambient light from the room when the lamps are turned on owing to the reflectances of items especially those directly in front of the display near the normal, e.g. the light reflecting from the front surfaces of the LMD, etc. It is assumed that the effects of light reflecting back when the lamps are turned on have been minimized so it can be ignored. With the lamps turned off (or completely obscured by means of a cover) measure the luminances of the screen  $L_a$  and the luminance of the white standard at the center of the screen  $L_{astd}$ .

**ANALYSIS:** Calculate the luminance factor:  $r_d = r_{std} L/L_{std}$ . Some may want to calculate the luminance coefficient as well:  $q = r_d / \pi$ . This equation is corrected for any ambient light by:  $r_d = r_{std} (L - L_a)/(L_{std} - L_{astd})$ .

**REPORTING:** Report the luminance factor  $r_d$  to no more than three significant figures.

**COMMENTS:** Tungsten and fluorescent ac-powered lamps may exhibit an ac fluctuation that can increase the imprecision of the measurements. See the Metrology Section on Auxiliary Laboratory Equipment (A113) for more details on making or obtaining a white diffuse standard.

This measurement is added to provide a level of compatibility with ISO 9241-7. See reference [3]. Please consider A217 Reflection Models for a more rigorous measurement proposal of reflectance parameters for modeling purposes.

Analysis and Reporting (Sample Data)	
Measure $L$ (cd/m <sup>2</sup> )	5.23
Measure $L_{std}$ (cd/m <sup>2</sup> )	108
$r_{std}$ (known)	0.970
Luminance Factor $r_d = r_{std} L/L_{std}$	0.0470
Luminance Coefficient $q = r_d / \pi$	0.0150

THE NIT IS A DEPRECATED UNIT!



It's a good thing we can say "watt"! Imagine: "Please give me a package of four 60-kilogram-meter-squared-per-second-cubed bulbs."



Whut?!



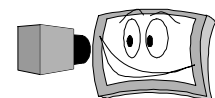
Nobody can accuse them of being nit-pickers!



The pressure today is 102430 kilograms-per-second-squared-per-meter.



Here's one: "I'd like 20 4.7 micro-amps-squared-seconds-to-the-fourth-killograms-to-the-minus-one-meters-to-the-minus-two capacitors for my project."





## 308-4 LARGE-SOURCE SPECULAR REFLECTANCE

### extended-source specular reflectance

**WARNING:** The correct measurement of this reflectance assumes that the display surface exhibits a specular component that produces a mirror-like distinct image where the reflected luminance  $L$  is related to the source luminance  $L_s$  by  $L = r_s L_s$ , where  $r_s$  is the specular reflectance. The surface is also assumed to have a Lambertian diffuse reflectance (away from the specular direction) where the illuminance and luminance are related by  $L = qE$ , and  $q = r_d / \pi$ , where  $r_d$  is the luminance factor. Applying this measurement to materials that have gain (i.e., exhibit a haze component of reflection) is, strictly speaking, incorrect. Not only are the results not simply interpreted by the above models, but also the measurement is subject to many errors from alignment of the components of the apparatus, the placement of the devices, and the characteristics of the devices. Employing this specular reflectance measurement for surfaces that have a significant haze reflection component can create irreproducible results. All interested parties should be cognizant of any misapplication of this measurement. See A217 BRDF Reflectance Model for further discussion of the components of reflection.

**DESCRIPTION:** With the DUT off (assumed to be its darkest state), the specular reflectance (mirror-like reflectance that produces a distinct image) is measured. **Units:** none. **Symbol:**  $r_s$ .

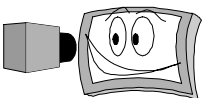
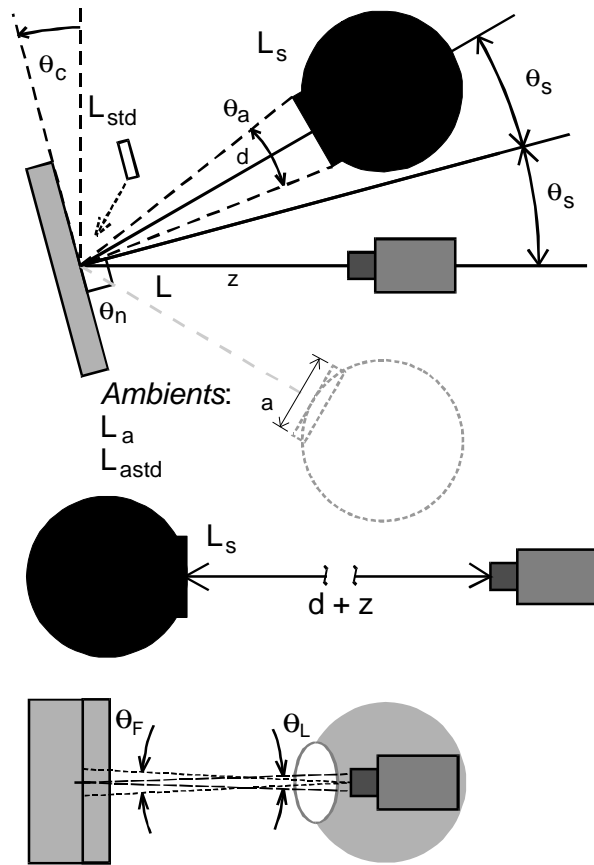
**NOTE:** If the powered-off state of the DUT is not the darkest condition of the DUT screen and the darkest screen is only obtainable with the DUT being powered, then this measurement may not be appropriate. In such cases be sure that all interested parties are in agreement in their expectations.

**SETUP:** A light source (lamp) and a diffuse white reflectance standard are needed.

**NOTE:** The specifications made upon the apparatus and the configuration presented below is especially important when the haze component of reflection is significant. If there is only a specular (mirror like) and diffuse (Lambertian) component of reflection (i.e., the haze component is trivial), then all these constraints become much less important, e.g., the diffuse reflectance should be independent of the angles from the normal, sizes, and distances of the lamps (if the surface is truly Lambertian) for a wide range of angles, sizes, and distances. To accommodate these two possibilities, two specifications are offered: one for no haze component and one for a non-trivial haze component. The tightening of the specifications is required whenever the haze component is significant in order to assure reproducibility of the measurement. How closely these tolerances are met will determine how reproducible the measurement is. The tolerances should be adequate to provide a  $\pm 5\%$  reproducibility of the reflectance measurement result.

**WHITE STANDARD:** A diffuse white reflectance standard of known luminance factor  $r_{std}$  is required in order to estimate the amount of non-specular reflection that needs to be subtracted from the specular luminance measurement  $L$ . When positioning the white standard be careful not to touch the display surface if it is delicate.

**LAMP AND LMD:** (Often this measurement is made after 308-4. The configuration can be obtained by rotating the display toward one of the lamps by  $15^\circ$ .) Initially, the LMD is placed at a distance of  $d + z$  away





from the exit port of a lamp having a round exit port of 150 mm in diameter, and the lamp luminance  $L_s$  is measured. (It is probably wise to check the lamp luminance after the measurement to be sure it hasn't changed if the lamp is not monitored by other means.) A lamp luminance  $L_s$  of 2000 cd/m<sup>2</sup> is preferred. The lamp should exhibit a  $\pm 1\%$  or smaller stability during the course of the measurements. After the direct measurement of the lamp luminance, the lamp is placed  $q_s = 15^\circ$  on one side of normal. The distance between the center of the exit port and the center of the screen is  $d$  (nominally 500 mm). The nonuniformity  $N = 1 - L_{\min}/L_{\max}$  over the exit port as well as the tolerance of the other parameters in the configuration depend upon the reflection properties of the screen. Table 1 lists the tolerances for the extreme conditions. The LMD is placed  $q_s = 15^\circ$  on the other side of the normal far enough away from the screen  $z$  that its surfaces are not directly illuminated by the lamp.

**AMBIENT LIGHT:** This measurement of the specular reflectance is less affected by ambient conditions than the measurement of diffuse reflectance in 308-3. Darkroom conditions should be maintained if at all possible. However, there are some cases where there is no recourse but to measure with some ambient light. Of course, we would prefer that the ambient luminance be significantly less than one half the luminance values obtained when the lamp is turned on. If so, it may be possible to successfully correct for ambient light. The luminances  $L_a$  and  $L_{\text{std}}$  are the luminances of center screen and the diffuse white standard at the center screen with the lamp off. Any nearby surfaces that can effect the measurement because of reflections should be covered with black felt or the equivalent. **NOTE:** Reflections off of nearby surfaces when the lamps are turned on can be a problem even in a darkroom.

**GENERAL SETUP CONDITIONS:** Display off in black state. See Section 301 for any standard setup details.



**PROCEDURE:** The luminance of the lamp is measured directly with the LMD a distance of  $d + z$  from the exit port of the lamp prior to configuring the apparatus. Measure at the center of the exit port within  $\pm 1^\circ$ . Then configure the reflection measurement apparatus and measure the luminance  $L$  of the center of the screen with the DUT off (unpowered or darkest black) and the lamp on. Attempt to measure the center of the virtual image of the source (whether distinct or fuzzy) within  $\pm 1^\circ$ , i.e., focus the LMD on the source (use a mirror if there is no specular reflection). There are two cases: Case 1 where the specular (mirror-like) component dominates, and case 2 where the non-specular components are important.

**Case 1: True specular reflection:** Examine the appearance of the reflected light of the lamp from the position of the LMD. If the virtual image is distinct and there is very little luminance ( $\leq 3\%$  of  $L$ ) from reflections outside the boundaries of the virtual image of the source then the reflection is principally specular (mirror-like). Measure only the luminance  $L$  of the center screen. If there is ambient illumination, also measure the luminance of screen center  $L_a$  with the lamp either off or completely obscured.

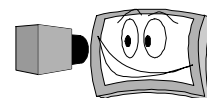
**Case 2: Non-specular components significant:** Examine the appearance of the reflected light of the lamp from the position of the LMD. If the virtual image is present but there is substantial luminance ( $\geq 3\%$  of  $L$ ) from reflections outside the boundaries of the virtual image of the source **or** no virtual image can be seen and only a fuzzy ball of light appears in the specular direction, measure the luminance  $L$  of the center screen, and then place a white diffuse standard of known reflectance  $r_{\text{std}}$  at the position of screen center and measure its luminance  $L_{\text{std}}$ . If there is ambient illumination, also measure the luminance of screen center  $L_a$  with the lamp either off or completely obscured. Be careful not to touch the surface of the screen if the screen is delicate.

**ANALYSIS:** There are two cases to analyze from the procedure section:

**Case 1:** If the examination of the appearance of the reflected light of the lamp from the position of the LMD showed that the virtual image is distinct and there is very little luminance reflected outside the boundaries of the virtual image of the source, then calculate the large-source specular reflectance:  $r_s = L/L_s$ . If ambient illumination is important use the corrected form  $r_s = (L - L_a)/(L_s - L_a)$ .

**Case 2:** If the examination of the appearance of the reflected light of the lamp from the position of the LMD showed that the virtual image is distinct but there is substantial luminance reflected beyond the virtual image of the source **or** no virtual image is observable only a fuzzy ball of light, then calculate the large-source specular reflectance making an attempt to subtract the diffuse background from the specular component using

Analysis and Reporting (Sample Data, Case 1)	
Measure $L_s$ (cd/m <sup>2</sup> )	12.0
Measure $L_s$ (cd/m <sup>2</sup> )	117
Specular Reflectance, $r_s = L/L_s$	0.103





the luminance factor value  $r_d$  obtained from 308-3:  $r_s = (L - r_d L_{std}/r_{std})/(L_s)$ . If ambient lights are important use the corrected form  $r_s = (L - L_a - r_d L_{std}/r_{std})/L_s$ . See comments below.

**REPORTING:** Report the large-source specular reflectance to no more than three significant figures.

**COMMENTS:** Tungsten and fluorescent ac-powered lamps may exhibit an ac fluctuation that can increase the imprecision of the measurements. See the Metrology Section on Auxiliary Laboratory Equipment (A113) for more details on making or obtaining a white diffuse standard.

Case 1 obeys the simple specular and simple diffuse (Lambertian) reflectance model. For such surfaces the large-source and small-source specular (308-5) reflectances should be approximately the same.

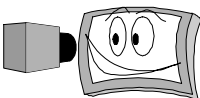
Case 2 is an approximate attempt to account for the non-specular reflectance by subtracting it from the specular component. The method specified for case 2 is correct for reflective surfaces for which only a specular and diffuse (Lambertian) component of reflection exists. It does not properly subtract the haze contribution to the reflection. It is a naïve model and can generate confusing results, for people will assume they have the correct specular reflectance and begin using the form  $L = r_s L_s$  with impunity. The fact that the next measurement, 308-5 Small-Source Specular Reflectance, was invented to provide another type of specular reflectance proves this. The large-source specular reflectance will include a strong contribution from haze whenever haze is nontrivial. The small-source specular reflectance will minimize the contribution from haze. Both methods (308-4 and 308-5) are non-rigorous characterizations of reflectance whenever haze is nontrivial.

This measurement is added to provide a level of compatibility with ISO 9241-7. See reference [3]. Please consider A217 Reflection Models for a more rigorous measurement proposal of reflectance parameters for modeling purposes.

**Table 1.** Large-Source Specular Reflectance Measurement Specifications

Symbol	Description	No Haze	Significant Haze
$L$	Luminance of screen, lamp on, measured at the center of the virtual image of the lamp within $\pm 1^\circ$	measured	
$L_s$	Luminance of lamp measured at the center of the exit port $\pm 1^\circ$	$\geq 2000 \text{ cd/m}^2$ preferred Stability: $\pm 1\%$ during measurement	
$L_{std}$	Luminance of diffuse white standard, lamp on	measured	
$q_n$	Angle of LMD relative to normal	$90^\circ \pm 5^\circ$	$90^\circ \pm 0.3^\circ$
$q_a$	Angle subtended by exit port of lamp	$15^\circ \pm 5^\circ$	$15^\circ \pm 0.3^\circ$
$q_s$	Angle of lamp center from normal	$15^\circ \pm 2^\circ$	$15^\circ \pm 0.3^\circ$
$q_s$	Angle of LMD optical axis from normal	$15^\circ \pm 2^\circ$	$15^\circ \pm 0.3^\circ$
$a$	Diameter of exit port of lamp	$(150 \pm 50) \text{ mm}$	$(150 \pm 2) \text{ mm}$
$z$	Distance between LMD and screen center	$\geq 500 \text{ mm}$	$\geq 500 \text{ mm}$
$d$	Distance between lamp center and screen	$(500 \pm 50) \text{ mm}$	$(570 \pm 5) \text{ mm}$
$q_F$	Angular field of view of LMD ( $\infty$ focus)	$\leq 3^\circ$	$\leq 1^\circ$
$q_L$	Angle subtended by LMD lens (entrance pupil)	$\leq 5^\circ$	$\leq 1^\circ$
$L_a$	Ambient luminance of screen, lamp off (LMD in same position as with the lamp on to measure $L$ above)	measured	
$r_s$	Specular reflectance without ambient light corruption	$r_s = L/L_s$	$r_s = \frac{L - r_d \frac{L_{std}}{r_{std}}}{L_s}$
$r_s$	Specular reflectance with ambient light correction	$r_s = \frac{L - L_a}{L_s}$	$r_s = \frac{L - L_a - r_d \frac{L_{std}}{r_{std}}}{L_s}$
$N$	Nonuniformity of exit port of lamp ( $1 - L_{min}/L_{max}$ )	$\leq 15\%$	$\leq 5\%$

\* **Note:** In accounting for some of the effects of haze, e.g.,  $r_s = (L - r_d L_{std}/r_{std})/(L_s)$ , the term  $r_d L_{std}/r_{std}$  can be rendered  $L_d L_{std}/L_{dstd}$ , where  $L_d$  is the luminance of the screen and  $L_{dstd}$  is the luminance of the white diffuse standard obtained from 308-3 Large-Source Diffuse Reflectance with the screen and white standard illuminated with the two lamps.





## 308-5 SMALL-SOURCE SPECULAR REFLECTANCE

**CAUTION:** The measurement of this type of reflection is an attempt to, in some way, account for the effects of haze (see A217 BRDF Reflectance Model) when the result is compared to the measurement of the specular reflectance in 308-4. If the display surface has only a specular (mirror-like, producing a distinct image) component and a diffuse (Lambertian) component of reflection, this measurement should yield the same result as 308-4 Specular Reflectance. If there is a significant haze component the value of the small-source specular reflectance will be smaller than the specular reflectance (extended source) since haze reflectance is sensitive to the illuminance from the source whereas the specular reflectance is sensitive to the luminance of the source. The illuminance from the extended source in 309-4 is significantly greater than the illuminance from the small source. Also, if there is a significant haze component, this measurement may be sensitive to placement of the LMD, the size of the entrance pupil of the LMD, the focus of the lens of the LMD, the AFOV of the LMD, as well as the placement, uniformity, and diameter of the light source. You can expect this measurement to be irreproducible and be very dependent upon apparatus and optical configurations when applied to surfaces with a significant haze reflection component. It is included in this document for the sake of completeness and history. All interested parties should be cognizant of any misapplication of this measurement. See A217 BRDF Reflectance Model for further discussion of the components of reflection.

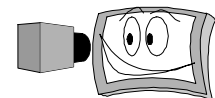
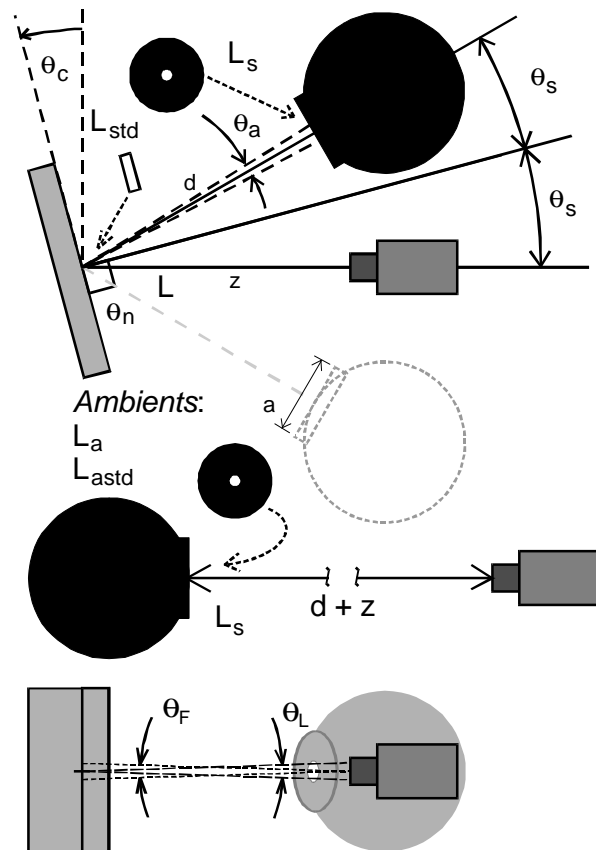
**DESCRIPTION:** With the DUT off (assumed to be its darkest state), the reflectance arising from a small source illumination is measured, and a coefficient for small-source specular reflectance is calculated.

**Units:** none. **Symbol:**  $r_{\text{small}}$ .

**NOTE:** If the powered-off state of the DUT is not the darkest condition of the DUT screen and the darkest screen is only obtainable with the DUT being powered, then this measurement may not be appropriate. Perform the Ambient Contrast (308-1) measurement instead.

**SETUP:** One small-diameter light source (lamp) and a diffuse white reflectance standard are needed. The figure shows the same configuration used for 308-3 (diffuse) and 308-4 (specular) with the display rotated  $15^\circ$  so that the angle between the normal of the screen and either the center of the source and the LMD is  $15^\circ$ . Only one source is employed. A large-diameter source (such as used in 308-3, 4) may be covered with an opaque black disk with a small hole at its center to act as a small-diameter light source. A fiber-optic light source of the same diameter or other light sources can be used as well, provided they are adequately uniform and stable. The goal is that the small source subtends  $1^\circ$  as viewed from the center of the screen.

**NOTE:** The specifications made upon the apparatus and the configuration presented below is especially important when the haze component of reflection is significant. If there is only a specular (mirror like) and diffuse (Lambertian) component of reflection (i.e., the haze component is trivial), then all these constraints become much less important, e.g., the diffuse reflectance should be independent of the angles from the normal, sizes, and distances of the lamps (if the surface is truly Lambertian) for a wide range of angles, sizes, and distances. To accommodate these two possibilities, two specifications are offered one for no haze component and one for a non-trivial haze component. The tightening of the specifications is required





whenever the haze component is significant in order to assure reproducibility of the measurement. How closely these tolerances are met will determine how reproducible the measurement is. The tolerances should be adequate to provide a  $\pm 5\%$  reproducibility of the reflectance measurement result.

**WHITE STANDARD:** A diffuse white reflectance standard of known luminance factor  $r_{\text{std}}$  is required in order to estimate the amount of non-specular reflection that needs to be subtracted from the specular luminance measurement  $L$ . When positioning the white standard be careful not to touch the display surface if it is delicate.

**LAMP AND LMD:** (Often this measurement is made after 308-4. The configuration can be obtained by rotating the display toward one of the lamps by  $15^\circ$ .) Initially, the LMD is placed at a distance of  $d + z$  away from the exit port of a lamp having a round exit port of 150 mm in diameter, and the lamp luminance  $L_s$  is measured. (It is probably wise to check the lamp luminance after the measurement to be sure it hasn't changed if the lamp is not monitored by other means.) A lamp luminance  $L_s$  of  $2000 \text{ cd/m}^2$  is preferred. The lamp should exhibit a  $\pm 1\%$  or smaller stability during the course of the measurements. After the direct measurement of the lamp luminance, the lamp is placed  $q_s = 15^\circ$  on one side of normal. The distance between the center of the exit port and the center of the screen is  $d$  (nominally 500 mm). The nonuniformity  $N = 1 - L_{\text{min}}/L_{\text{max}}$  over the exit port as well as the tolerance of the other parameters in the configuration depend upon the reflection properties of the screen. Table 1 lists the tolerances for the extreme conditions. The LMD is placed  $q_s = 15^\circ$  on the other side of the normal far enough away from the screen  $z$  that the surfaces of the LMD are not directly illuminated by the lamp.

**AMBIENT LIGHT:** This measurement of the small-source specular reflectance is less affected by ambient conditions than the measurement of diffuse reflectance in 308-3 but can be affected more than the large-source specular reflectance in 308-4. Darkroom conditions should be maintained if at all possible. However, there are some cases where there is no recourse but to measure with some ambient light. Of course, we would prefer that the ambient luminance be significantly less than one half the luminance values obtained when the lamp is turned on. If so, it may be possible to successfully correct for ambient light. The luminances  $L_a$  and  $L_{\text{std}}$  are the luminances of center screen and the diffuse white standard at the center screen with the lamp off. Any nearby surfaces that can effect the measurement because of reflections should be covered with black felt or the equivalent. **NOTE:** Reflections off of nearby surfaces when the lamp is turned on can be a problem even in a darkroom.

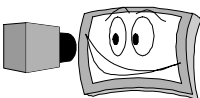
**GENERAL SETUP CONDITIONS:** Display off in black state. See Section 301 for any standard setup details.



**PROCEDURE:** The luminance of the lamp is measured directly with the LMD a distance of  $d + z$  from the exit port of the lamp prior to configuring the apparatus. Measure at the center of the small-source exit port. Then configure the reflection measurement apparatus and measure the luminance  $L$  of the center of the screen with the DUT off (unpowered or darkest black) and the lamp on. Focus the LMD on the source (use a mirror if there is no specular reflection). Attempt to measure the center of the virtual image of the source (whether distinct or fuzzy). There are two cases: Case 1 where the specular (mirror-like) component dominates, and case 2 where the non-specular components are important.

**Case 1: True specular reflection:** Examine the appearance of the reflected light of the lamp from the position of the LMD. If the virtual image is distinct and there is very little luminance ( $\leq 3\%$  of  $L$ ) from reflections outside the boundaries of the virtual image of the source then the reflection is principally specular (mirror-like). Measure only the luminance  $L$  of the center screen at the center of the virtual image. If there is a thick faceplate or separated reflecting surfaces, then two reflected virtual images (fuzzy or distinct) may be observed. If this happens for a CRT with a curved faceplate, then rotate the display about the center of the screen until both virtual images are aligned as best as possible, and then measure  $L$ . If you have two reflections using a FPD, then reduce the  $q_s = 15^\circ$  as much as your equipment will allow to overlap the reflections. If there is ambient illumination, also measure the luminance of screen center  $L_a$  with the lamp either off or completely obscured.

**Case 2: Non-specular components significant:** Examine the appearance of the reflected light of the lamp from the position of the LMD. If the virtual image is present but there is substantial luminance ( $\geq 3\%$  of  $L$ ) from reflections outside the boundaries of the virtual image of the source **or** no virtual image can be seen and only a fuzzy ball of light appears in the specular direction, measure the luminance  $L$  of the center screen, and





then place a white diffuse standard of known reflectance  $r_{\text{std}}$  at the position of screen center and measure its luminance  $L_{\text{std}}$ . If there is a thick faceplate or separated reflecting surfaces, then two reflected virtual images (fuzzy or distinct) may be observed. If this happens for a CRT with a curved faceplate, then rotate the display about the center of the screen until both virtual images are aligned as best as possible, and then measure  $L$ . If you have two reflections using a FPD, then reduce the  $q_s = 15^\circ$  as much as your equipment will allow to overlap the reflections. If there is ambient illumination, also measure the luminance of screen center  $L_a$  with the lamp either off or completely obscured. Be careful not to touch the surface of the screen if the screen is delicate.

**ANALYSIS:** There are two cases to analyze from the procedure section:

**Case 1:** If the examination of the appearance of the reflected light of the lamp from the position of the LMD showed that the virtual image is distinct and there is very little luminance reflected outside the boundaries of the virtual image of the source, then calculate the small-source specular reflectance:  $r_{\text{small}} = L/L_s$ . If ambient illumination is important use the corrected form  $r_{\text{small}} = (L - L_a)/(L_s - L_a)$ .

**Case 2:** If the examination of the appearance of the reflected light of the lamp from the position of the LMD showed that the virtual image is distinct but there is substantial luminance reflected beyond the virtual image of the source *or* no virtual image is observable only a fuzzy ball of light, then calculate the small-source specular reflectance making an attempt to subtract the diffuse background from the specular component using the luminance factor value  $r_d$  obtained from 308-3:  $r_{\text{small}} = (L - r_d L_{\text{std}}/r_{\text{std}})/L_s$ . If ambient lights are important use the corrected form  $r_{\text{small}} = (L - L_a - r_d L_{\text{std}}/r_{\text{std}})/L_s$ . See comments below.

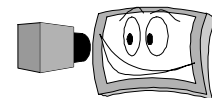
**REPORTING:** Report the small-source specular reflectance to no more than three significant figures.

**COMMENTS:** Tungsten and fluorescent ac-powered lamps may exhibit an ac fluctuation that can increase the imprecision of the measurements. See the Metrology Section on Auxiliary Laboratory Equipment (A113) for more details on making or obtaining a white diffuse standard.

Case 1 obeys the simple specular and simple diffuse (Lambertian) reflectance model. For such surfaces the large-source (308-4) and small-source specular reflectances should be approximately the same.

Case 2 is an approximate attempt to account for the non-specular reflectance by subtracting it from the specular component. The method specified for case 2 is correct for reflective surfaces for which only a specular and diffuse (Lambertian) component of reflection exists. It does not properly subtract the haze contribution to the reflection. It is a naïve model and can generate confusing results, for people will assume they have the correct specular reflectance and begin using the form  $L = r_{\text{small}} L_s$  with impunity. The fact that this small-source measurement was invented to provide another type of specular reflectance proves this. The large-source specular reflectance will include a strong contribution from haze whenever haze is nontrivial. The small-source specular reflectance will minimize the contribution from haze. Both methods (308-4 and 308-5) are non-rigorous characterizations of reflectance whenever haze is nontrivial. Please consider A217 Reflection Models for a more rigorous measurement proposal of reflectance parameters for modeling purposes.

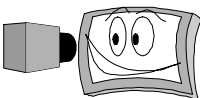
Analysis and Reporting (Sample Data)	
Measure $L$ ( $\text{cd}/\text{m}^2$ )	12.0
Measure $L_s$ ( $\text{cd}/\text{m}^2$ )	117
Specular Reflectance, $r_{\text{small}} = L/L_s$	0.103

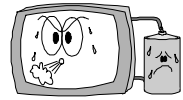


**Table 1.** Small-Source Specular Reflectance Measurement Specifications

Symbol	Description	No Haze	Significant Haze
$L$	Luminance of screen, lamp on, at center of reflected image (the screen may have to be rotated about its center about the vertical axis to align two reflected images when the reflecting surfaces are separated)	measured	
$L_s$	Luminance of lamp at its center	$\geq 2000 \text{ cd/m}^2$ preferred Stability: $\pm 1\%$ during measurement	
$L_{\text{std}}$	Luminance of diffuse white standard, lamp on	measured	
$q_n$	Identification of the normal initially (may change if the display needs to be rotated to align multiple images from separated surfaces)	$90^\circ \pm 5^\circ$	$90^\circ \pm 1^\circ$
$q_a$	Angle subtended by small exit port of lamp	$2^\circ \pm 1^\circ$	$1^\circ \pm 0.01^\circ$
$q_s$	Angle of lamp center from normal and angle of LMD from normal. Small adjustments may be made to capture the center of the reflected image.	$15^\circ \pm 1^\circ$	$15^\circ \pm 1^\circ$
$a$	Diameter of exit port of lamp	$(20 \pm 10) \text{ mm}$	$(10 \pm 0.1) \text{ mm}$
$z$	Distance between LMD and screen center	$\geq 500 \text{ mm}$	$\geq 500 \text{ mm}$
$d$	Distance between lamp centers and screen	$(500 \pm 50) \text{ mm}$	$(573 \pm 5) \text{ mm}$
$q_F$	Angular field of view of LMD ( $\infty$ focus)	$\leq 1^\circ$	$\leq 0.3^\circ$
$q_L$	Angle subtended by LMD lens (entrance pupil)	$\leq 5^\circ$	$\leq 1^\circ$
$L_a$	Ambient luminance of screen, lamp off (LMD in same position as with the lamp on to measure $L$ above)	measured	
$r_{\text{small}}$	Specular reflectance without ambient light corruption	$r_{\text{small}} = L/L_s$	$r_{\text{small}} = \frac{L - r_d \frac{L_{\text{std}}}{r_{\text{std}}}}{L_s}$
$r_{\text{small}}$	Specular reflectance with ambient light correction	$r_{\text{small}} = \frac{L - L_a}{L_s}$	$r_{\text{small}} = \frac{L - L_a - r_d \frac{L_{\text{std}}}{r_{\text{std}}}}{L_s}$
$N$	Nonuniformity of exit port of lamp ( $1 - L_{\text{min}}/L_{\text{max}}$ )	$\leq 10\%$	$\leq 5\%$

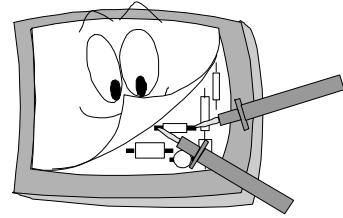
\* **Note:** In accounting for some of the effects of haze, e.g.,  $r_s = (L - r_d L_{\text{std}}/r_{\text{std}})/(L_s)$ , the term  $r_d L_{\text{std}}/r_{\text{std}}$  can be rendered  $L_{\text{std}} L_d/L_{\text{dstd}}$ , where  $L_d$  is the luminance of the screen and  $L_{\text{dstd}}$  is the luminance of the white diffuse standard obtained from 308-3 Large-Source Diffuse Reflectance with the screen and white standard illuminated with the two lamps.





## 400 ELECTRICAL PERFORMANCE

**Electrical Power Measurements:** Making an electrical power measurement on a display assumes that the circuitry is accessible or the display is powered by a power source separate from the display. In many cases the DUT can have an integrated power source that does not lend itself to measurement such as in a laptop computer. In such cases many would be hesitant to break into the enclosure and tap into the powering lines to the display. In such cases the manufacturing data may be the only source of information as to the power consumption of the DUT.



### 401 POWER CONSUMPTION & SUPPLY

**401-1 POWER CONSUMPTION** — *Note: If any measurement in 402 (Efficiencies) will be made, be sure to measure the power with a white full screen in addition to any other pattern otherwise chosen.*

### 401-2 POWER SUPPLY RANGE VERIFICATION

**Efficiency:** The term “luminous efficiency” in the CIE definition means the number of lumens per optical power [W] of radiation. The term “luminous efficacy” is used by the CIE to characterize the luminous flux per watt of electrical energy input (lm/W). “Efficiency” is more familiar to many. Generally speaking, the efficiency characterizes how well the display converts electrical power into visible light. Note that Procedure 401-1 is Frontal Luminance Efficiency. Since some displays can emit quite a bit of light away from the normal without much desirable information content, we felt that the frontal luminance efficiency was a reasonable metric to introduce. It is, perhaps, a better metric for characterizing display performance than the luminous efficacy (“efficiency”). Luminous efficacy (“efficiency”), on the other hand, is a type of power ratio that characterizes the visible “power” output in all directions vs. the electrical power input (the luminous flux is what some have called a “light watt”). One obvious advantage using the frontal luminance efficiency is that neither a large integrating sphere, goniophotometric sampling, nor other expensive apparatus is needed to make the measurement provided a power measurement or characterization is available.

### 402 EFFICIENCIES

#### 402-1 FRONTAL LUMINANCE EFFICIENCY - $e$

#### 402-2 LUMINOUS EFFICACY- $h$

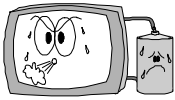


I've put in dummy numbers to show how its done.



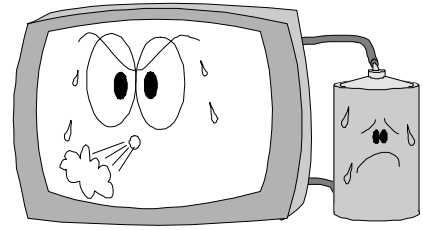
Yes, we noticed. "Sample data" wouldn't capture the essence of your contribution.





## 401 POWER CONSUMPTION & SUPPLY

Concern for the measurement of electrical power required by a display might be prompted by a number of requirements or factors: low power drain on batteries for a laptop or hand-held device, air conditioning needed to handle the heating from displays used in an enclosure, drain on power sources in a vehicle, etc. Unless you are able to access the power lines to the display these measurements will not be possible. In such cases manufacturing data may be the only source of information. Some displays require a backlight and manufacturers like to separate the power requirements of the light-valve matrix and associated electronics from the power requirements of the backlight. If the backlight is necessary for the task conditions, then its power should be included in the total power required to run the display. In complicated situations, all interested parties will have to agree on how to resolve any irregularities.



Another concern is for the range of power sources that are acceptable to the display for proper operation. Cost factors may be involved in the required accuracy of the power requirements. For this reason there is a measurement included that verifies the operating range of the DUT.

### 401-1 POWER CONSUMPTION

*Note: If any measurement in 402 (Efficiencies) will be made, be sure to measure the power with a white full screen in addition to any other pattern otherwise chosen.*

### 401-2 POWER SUPPLY RANGE VERIFICATION

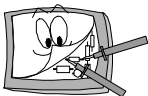
This is a bad idea! It needs much more!!

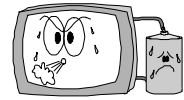


But you were the one who wanted it that way. We changed them all to suit you!



Well, I've changed my mind.





## 401-1 POWER CONSUMPTION

(power dissipation, total power)



**DESCRIPTION:** We measure the power consumption of the DUT. **Units:** W (watt).

**Symbol:** *P*.

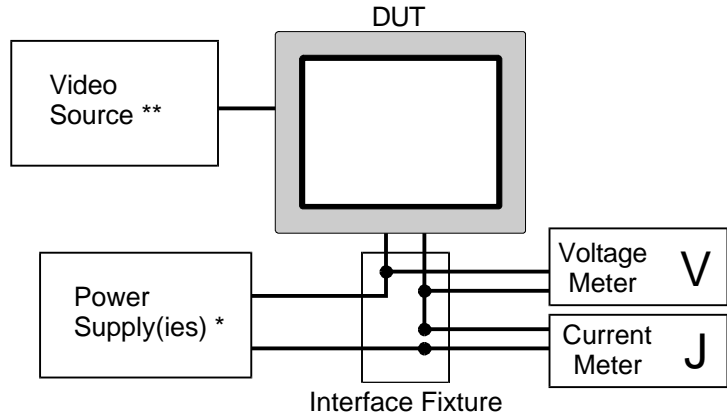
**CAUTION — EXCESSIVE VOLTAGE CAN DESTROY THE DISPLAY:**  
*When supplying power to any display from an external source over which you have control, always adjust the voltage to the manufacturer's specifications before connecting the display. If too much voltage is inadvertently applied it can destroy the display.*



Power Consumption is the total power used by the DUT for operation. It should be measured using a displayed video pattern that produces the greatest amount of current draw for the DUT from the applied voltage(s). The applied voltage should be well regulated and have sufficient current capability so that it does not change when the display current changes.

Many LCDs have inverters to power backlighting systems, and the power required for the backlight is part of the total display power, since the DUT will not be fully usable without its operation. Inverters convert dc voltage to ac to drive fluorescent lamps that produce the brightness for LCDs. That process produces conversion losses, and causes additional power consumption that is not part of the actual display power consumption. The true power consumption for LCDs with backlights must include the total power as seen at the input of the inverter to be the total value. For inverter power measurements, the displayed video does not matter, since the inverter power consumption is non-video-related. Note: in this version of the document, no recommendations are made to measure the power at the output of the inverter (the backlight input).

The total power consumption is the display power plus the inverter power (if applicable) or other backlight/projector lighting, and in some cases may include non-display related power, such as in monitors where the display supply voltage also supplies other circuits, such as USB or 1394 interfaces, or audio or non-display video circuits. In addition, some monitors may have ac voltage input, requiring ac/dc converters, which produce additional power due to their conversion loss inefficiencies. The power required for a backlight for an LCD or lighting systems to produce light for a reflecting or projector display, must always be included in the total power consumption.



Power is always additive, so the total power is the sum of all the individual powers, including the backlight with inverter (where applicable), the display or panel, and any other incidental power (such as USB, 1394, etc.) when the total power of a monitor which contains such circuits is desired.

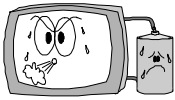
**NOTE:** Power *P* is the product of the voltage *V* and current *J*:  $P = VJ$ .

$$P = VJ \begin{cases} P = \text{power in watts (W)} \\ V = \text{voltage in volts (V)} \\ J = \text{current in amps (A)} \end{cases}$$

(For ac the voltage and current would be the root-mean-square ["rms" or "RMS"] values.) If a direct power reading instrument is employed to make the power measurements, use its numbers directly without voltage and current measurement or calculations.

ELECTRICAL





	Case 1	<b>Case 2 (preferred)</b>	Case 3	Case 4
	Embedded Display	Standalone FPD & Projector Engines	FP Monitor & Projection Systems	FP Monitor with additional circuits
Measure Power?	no *	yes **	yes	maybe (user option)

\*Embedded system, such as for an enclosed laptop computer. For exception cases in which the display power can be measured, see text below.

\*\*Case 2 is the preferred method of testing, and should be used whenever possible.

**NOTE:** If the supply line is to be interrupted and the current measured in series with the power source, a special interface fixture may be needed to measure the current.

	Case 1	Case 2	Case 3	Case 4	Comments
Conditions	Embedded Display	Standalone FPDs & Projector Engines	FP Monitor & Projection Systems	FP Monitor ** with additional circuits	
ac supply	--	no	maybe *	maybe *	Convert to RMS
dc supply	--	yes	yes	maybe **	
multiple dc supplies	--	yes	yes	maybe **	Sum all supplies

\* Measurement of a monitor with ac input will include non display-related losses due to the inefficiencies of the ac/dc conversion process. This assumes dc input to any DUT being measured. That is not part of the display power consumption directly, and it is up to the user if he/she chooses to include or exclude that.

\*\*FPD monitors with additional (non-video-related) circuits may have the input power measured just as in Case 3, but the usefulness of the total power must be determined by the user.

	Case 1	Case 2	Case 3	Case 4	Comments
Conditions	Embedded Display	Standalone FPDs & Projector Engines	FP Monitor * & Projection Systems	FP Monitor * with additional circuits	
Backlight*	--	maybe	maybe	maybe	Add backlight power to total

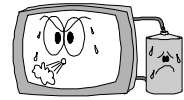
\*Backlights, or external luminance sources may be of several types. They may include a fluorescent-tube backlight, other types of backlights, such as LEDs or EL, or rear or reflected lamps, such as for projector applications.

**Case 1:** A DUT which is integrated in a system, in which the system supply powers both the system and the DUT, with no access to the power that goes directly to the DUT. An example would be an enclosed laptop computer. In this case, the display power usually cannot be determined and power consumption for the displays are not realizable. (Note: Under special conditions, power for the DUT can be measured in an embedded system. These conditions would either entail disassembly of the system sufficiently to gain access to the voltage source to the DUT and inverter, or entail knowledge of the total system power and being able to subtract that from the power of the display. It is up to the user to determine if such measurements are practical for his conditions.)

**Case 2:** A standalone display (which will include an inverter for many LCDs), the total power is equal to  $P_{\text{display}}$ , or  $P_{\text{display}} + P_{\text{inverter}}$ \*, if the DUT has an inverter. Note that for displays which have multiple voltage supplies, such as +5V and +12V, that the power of all individual sources are added, such as  $P_{\text{display}} = (P_{5V} + P_{12V} + P_{\text{inverter}})$ . Case 2 is the preferred method of testing, and should be used whenever possible.

**Case 3a:** A flat panel monitor which contains no circuitry other than for the DUT (perhaps with inverter), and is powered entirely by ac (line voltage) only. The total power of the DUT is the power read at the ac input. e.g.  $P_{\text{display}} = P_{\text{ac}}$





**Case 3b:** A flat panel monitor that contains no circuitry other than the DUT (perhaps with inverter), and is powered by dc. The total power of the DUT is the power read at the dc input. e.g.  $P_{\text{display}} = P_{\text{dc}}$ . If there is more than one dc source, then add the individual powers of each, such as  $P_{\text{display}} = P_{\text{dc1}} + P_{\text{dc2}} + \dots + P_{\text{dcn}} + P_{\text{inverter}}^*$ .

**Case 4:** A flat panel monitor which contains non-video related power-consuming circuits, such as USB, 1394, audio amplifier power, etc., and the total power of the monitor is to be considered, then the total power is equal to the sum of the individual powers. For example, total power  $P_{\text{total}} = P_{\text{display}} + P_{\text{inverter}}^* + P_a + P_b + \dots + P_n$ , where  $P_a, P_b, \dots, P_n$ , are the powers of each non-video circuit section, such as USB, 1394, audio power, etc.

*Note: For Case 4, you must determine if measuring the DUT plus the other circuits in a monitor system is the most useful information for the specific power consumption evaluation, since the other power consumed is not actually part of the display power.*

\*This may be for inverter or other display lighting power. Eliminate the  $P_{\text{inverter}}$  term if the DUT has no inverter (or set it to be "0") or lighting power circuits.

## SETUP:

### 1. EQUIPMENT

**Alternative 1:** An ac-operated display (in which the ac powers the display only), e.g. might be found for Case 3 or Case 4.

- An ac power measurement test set which reads ac power directly, or  $P$ .
- Separate RMS voltage and current measurement equipment, or  $P = V_{\text{rms}} J_{\text{rms}}$
- Peak-to-peak (p-p) voltage, current measurement equipment, for which  $P = \frac{V_{\text{p-p}}}{2\sqrt{2}} \frac{J_{\text{p-p}}}{2\sqrt{2}}$
- Frequency of the ac voltage should also be recorded whenever ac is employed.

**Alternative 2:** An external display\*, in which the display power source(s) is accessible independent of a system, and externally powered (generally by dc). e.g. Case 2, Case 1 with some disassembly, or might for Case 3.

- dc voltage meter
- dc current meter (It may be necessary to interrupt the supply or supplies and place the current meter in series with the supply). Note: A special interface fixture may be needed to accomplish this.
- Set voltages of external power supplies for the display rated voltage(s)  $\pm 1\%$ .
- Power Measurement ( $V_i$  and  $J_i$  are dc values and "inv" is inverter):  $P = V_a J_a + V_b J_b + \dots + V_{\text{inv}} J_{\text{inv}}^*$

**Note:** Depending upon the display, this may involve one or more than one supplies for the display, and one or more for the backlight inverter. The total power is equal to the sum of each of the individual powers. **Note: Alternative 2 will provide the most accurate readings and is the preferred electrical setup method whenever possible.**

\*With backlight where applicable, such as for many LCDs. It is included since the backlight is part of the total power consumed by the display. For cases with no inverter, delete this term.

### 2. SETUP PROCEDURE

- Connect voltage(s) to the display, inverter, and any other display-related circuits. Set the voltage to its specified value as accurately as possible (goal:  $< \pm 0.5\%$ )
- Display video pattern that produces the worst case power for the display.

If the user does not know in advance what that displayed pattern for worst case pattern may be, then it may be necessary to try various patterns while monitoring the current drawn by the display.

**Note:** If you intend to determine the frontal luminance efficiency  $e$  (402-1) be sure to measure the power using a white full screen in addition to any other pattern that might be used.

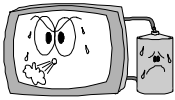
- Measure the power for each supply and calculate the display power consumption as follows:

$$P_{\text{total}} = V_1 J_1 + V_2 J_2 + \dots + V_n J_n + V_{\text{inv}} J_{\text{inv}} = P_1 + P_2 + \dots + P_n + P_{\text{inv}},$$

where  $V_1, V_2, \dots, V_n =$  All voltages applied to the display,  
 $J_1, J_2, \dots, J_n =$  All currents to the display,  
 $V_{\text{inv}}, J_{\text{inv}} =$  Backlight inverter voltage and current.

For displays which have no inverter, disregard the inverter power measurements (set to zero) and use display power only for the total power.





For displays which have multiple supply voltages (to the display only), then the power for each supply must be determined, and all added together to determine total power for the display. If the display has different power consumption for different video patterns for each supply, then a single pattern should be selected by the tester and used for all the power measurements. *Note that if the frontal luminance efficiency (402-1) is to be measured a white full-screen is required in addition to any other pattern selected.*

When only line input can be measured, power can be determined by using ac power meters or by actual measurements of the voltage and current and multiplying them. The resultant power should always be in RMS. For displays integrated into systems in which the power source provides power to other circuits in addition to the display, such as laptops or displays with additional internal circuits, and the power to the display cannot be isolated for measurement, then the power consumption may be difficult to determine. The user may want to not include power measurements in such cases.

#### PROCEDURE:

1. Adjust the power input for specified values,  $\pm 1\%$  (goal  $< \pm 0.5\%$ ).
2. Attach voltage and current measuring devices (or power measurement devices) to the input.
3. Display the desired pattern on the screen:
  - a) Worst case pattern: The pattern that causes the greatest amount of power consumption such as an alternating pixel pattern.
  - b) White screen: Display a full luminance, all white full-screen display (as in 302-1, Luminance and Color of Full-Screen White).
4. Inverter (for displays that use an inverter to power a backlight ):
 

Note: For measurement of inverter power for LCDs, power will not vary dependant on the displayed video.

  1. Apply the rated voltage input for specified value,  $\pm 1\%$  (goal  $< \pm 0.5\%$ ). This is  $V_{inv}$  or  $V_{inverter}$ .
  2. Set the inverter adjustment (if there is one) for maximum output (that is, maximum luminance).
  3. Measure the input current to the inverter. This is  $J_{inv}$  or  $J_{inverter}$ .
  4. Backlight (or inverter) power =  $V_{inv} I_{inv}$ .
5. Video Pattern: If luminance is important, measure the luminance at the front center of the screen, using standard measurement techniques (see 302-1, Luminance and Color of Full-Screen White). If the frontal luminance efficiency (402-1) is to be determined then a full-screen white pattern must be also be used in addition to any other pattern selected. If the frontal luminance efficiency is not to be determined, any video can be used that maximizes the power consumption.

**ANALYSIS:** Perform necessary calculations to fill in Table 4.

#### REPORTING:

Report the following on the reporting sheet: Video pattern used, input voltage (all), input current (all), input power (all), and the total power consumption

Table 4: Power Consumption Reporting - Sample Data				
Pattern Used:	1 pixel	1 pixel alternating	pixel pattern	
Input Supply	Volts, V (in V)	Current, I (in A)	Power, P (in W)*	
Panel	5.2	0.4	2.08	$P_{pan} = V_{pan} J_{pan}$
Inverter **	12.05	0.502	6.05	$P_{inv} = V_{inv} J_{inv}$ **
Total *	—	—	8.13	$P = P_{pan} + P_{inv}$ **

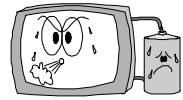
$$*Total\ Power = P_{display} + P_{inverter}^{**} + P_{other}^{**}$$

\*\*If used

\* Note: For additional voltage sources and their associated currents, report their values on comment sheet.

\* If ac voltage is used, report the voltage frequency.





## 401-2 POWER SUPPLY RANGE VERIFICATION

**DESCRIPTION:** This section provides guidelines on measuring the display operation over the specified voltage operating range. These measurements can only be made for any case in which the user can provide power for the isolated display or tap into the power on a display integrated into a system. It is assumed that the power to the display can be isolated and measured independently of supplying power to any non-display-related circuits. If the power is measured but also supplies other circuits, then the display power consumption reading may be useless.

It is considered that this test applies to dc power sources. Some technologies, may have ac input, or it may be desired that the total power of the display including an ac source be tested. That may be done at the discretion of the user, but detailed information is beyond the scope of discussion in this test.

**Note:** Either perform this measurement before all other measurements or after all other measurements requiring display settings not to be changed. The adjustment of display controls calls for upsetting setup conditions that may be hard to reset accurately.

**Caution: Care must be given to applying voltage(s). If an excessive voltage is applied it can destroy the panel.**

Conditions to perform this test:

1. External, adjustable power supply is used (unless internal power supply can be adjusted over the specified operating range)
2. Power is isolated to supply the display and related circuitry (e.g., inverter) only.
3. An interface to apply the external voltage and measure the current.

**DANGER**  
DAMAGE  
TO DISPLAY  
POSSIBLE

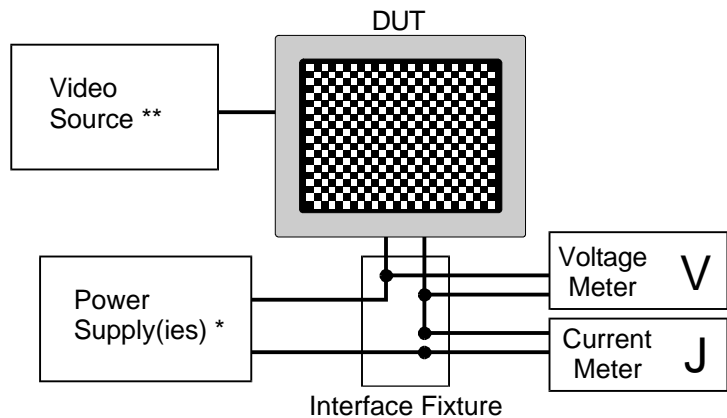
### SETUP & PROCEDURE & ANALYSIS:

Using an adequate interface for supplying the voltage(s) and measuring the current, perform the following steps.

\* **CAUTION:** Adjust and measure the voltage before applying it to the panel to avoid damage from excess voltage.

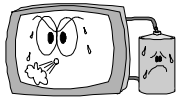
\*\* **CAUTION** must be exercised to comply with any power sequencing issues with the display, such as sequence of applying voltage(s) and video, if necessary.

- a) Apply a controlled voltage (or voltages) to the display.
- b) Assure proper measurement equipment is used to determine the voltage and current, or power.
- d) Display video content that is suitable to demonstrate worst-case power consumption by monitoring the supply current while changing video. (Note that the inverter power is independent of video content.)
- e) Vary the voltage for each of the high, exact, and low settings, and measure the input voltage(s), current(s) and calculate the resulting input powers. Combine all power into a final total power consumption.



ELECTRICAL





**REPORTING:**

Report the following on the reporting sheet

- Input Voltage (all)
- Input Current (all)
- Input Power (all)
- Total Power Consumption
- Displayed video content (if practical)

Table 1. Power Supply Range Reporting					
Video Content (Pattern Used)		2 pixel checker board			
Input Supply		Volts (V)	Current, I (A)	Power (W)*	
Panel	High	5.5	0.5	2.75	$P_{panhigh} = V_{high} J_{high}$
	Exact Value	5.0	0.5	2.5	$P_{pan} = V J$
	Low	4.5	0.5	2.25	$P_{panlow} = V_{low} J_{low}$
Inverter ***	High	12.5	0.6	7.5	$P_{invhigh} = V_{high} J_{high}$
	Exact Value	12	0.6	7.2	$P_{inv} = V J$
	Low	11.5	0.6	6.9	$P_{invlow} = V_{low} J_{low}$
Total Power **		High **		10.25	$P = P_{panhigh} + P_{invhigh} ***$
		Exact Value **		9.7	$P = P_{pan} + P_{inv} ***$
		Low **		9.15	$P = P_{panlow} + P_{invlow} ***$

\*Power =  $V \times I = V \cdot I = V I$

\*\*Total Power =  $P_{display} + P_{inverter} *** + P_{other} ***$

\*\*\*If used

Note: For additional voltage sources and their associated currents, report their values on the comment sheet.

**COMMENTS:** None

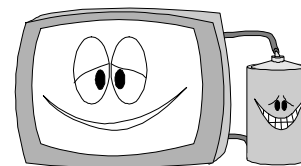
ELECTRICAL





## 402 EFFICIENCIES

The luminous efficacy (“efficiency”) of a display is the ratio of the light flux output for the entire display vs. the electrical power input to the display. This is often called the luminous efficiency but is more properly called the luminous efficacy, and has been used for years in evaluating displays especially that exhibit a quasi-Lambertian light output like CRTs. (The CIE reserves the term “luminous efficiency” to mean the ratio of the luminous flux in lumens to the optical power [W] of the radiation.) However, some FPD technologies do not display a Lambertian-type of luminance distribution. Some displays produce no information output in certain directions but emit much light in those directions. Some displays are privacy displays that emit the information in a narrow solid angle along the normal (or other direction), but any light at larger angles from the normal contains no information. For these reasons some have felt that rating the display solely on the luminous efficacy is not always a good indicator of the effectiveness of the display in converting electrical power to light. To answer this need to provide a metric that enables an immediate evaluation of how much power is spent on producing the luminance the user will see, we offer the frontal luminance efficiency.

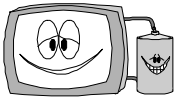


In the reviews of this document, the generation of a new metric, the frontal luminance efficiency, was disturbing to some. On the other hand, others applauded the metric. It is felt by the working group that the frontal luminance efficiency was a better measure of performance vs. price (power) for many applications such as workstation, computer monitors, laptops, etc. Which metric, luminous efficacy or frontal luminance efficiency, you use will depend upon your applications, desired comparisons, and specifications. Frontal luminance efficiency is a much more intuitive metric of what the display could do for certain tasks as viewed from the design viewing direction (quasi-perpendicular in most cases). To say that a display has a luminous efficacy of 30 lm/W says *nothing* about how the display will look for your investment of power unless you know the viewing angle characteristics of the luminance distribution and the area of the display. Even if you do know the luminance distribution and the screen area, a calculation is required to determine how bright the screen will look to a normal viewer. But to say that the display has a frontal luminance efficiency of 100 cd/m<sup>2</sup>/W means that this display is very bright for very little power. For some applications, frontal luminance efficiency is what is of interest.

For example, two laptop displays could have the same luminous efficacy, but one might have a wide viewing angle (quasi-Lambertian) and the other might cleverly concentrate all its light in a narrow cone in the direction of the viewer. The second laptop display will appear much brighter to the user than the first, and that may be what is important to this application. The metric of interest for such tasks is the luminance obtained for the electrical power used, not how much light it is pumping out in all directions. Again, all of this is task dependent. Let’s work out an example of this—see A224 (Luminance of Lambertian Display &  $h$ ). Suppose a display with area  $A = 400 \text{ mm} \times 300 \text{ mm} = 0.12 \text{ m}^2$  has a Lambertian luminous intensity distribution, and that the display has a luminous efficacy of  $h = 15 \text{ lm/W}$ . The luminous flux obtained for  $P = 3 \text{ W}$  is  $F = hP = 45 \text{ lm}$ . That light is distributed in  $2\pi$  steradians, not uniformly, but as from a Lambertian emitter. The flux is  $F = \pi LA$ , so that  $L = hP/\pi A = 119 \text{ cd/m}^2$ . The frontal luminance efficiency of this display would be  $e = 40 \text{ cd/m}^2/\text{W}$  (here is where we need the nit!). Suppose someone cleverly constructed a display so that all its light was uniformly directed to be confined within a cone having a solid angle of  $\Omega = 0.5 \text{ sr}$  (such a cone would have an apex angle of  $46^\circ$ ) centered about the normal. Given the same efficiency and power, how bright would the display be? The flux is  $F' = I\Omega = L'A\Omega$ , and  $L' = hP/A\Omega = 750 \text{ cd/m}^2$ . The displays have the same luminous efficacy and the same power, but the display with the narrow-cone output will appear to the eye to be 1.8 times brighter ( $\sqrt[3]{L'/L} = 1.8$ , with  $L'/L = 6.3$ ; see A209, Nonlinear Response of the Eye). The frontal luminance efficiency of the special display would be  $e = 250 \text{ cd/m}^2/\text{W}$ .

Luminous efficacy certainly has its place, especially for quasi-Lambertian displays and projection displays; and is retained in this document (402-2). However, for many technologies used at the present time, a number of people want to know how bright their display will be for their investment of electrical power. As such, they are not interested in the light distributed away from the viewing direction.





## 402-1 FRONTAL LUMINANCE EFFICIENCY – $e$

luminance to power ratio, luminance efficiency, power conversion efficiency,  
**[NOT luminous efficiency, NOT luminous efficacy]**



**DESCRIPTION:** The frontal luminance efficiency is the ratio of the luminance to the driving power of the DUT. It is a simple calculation based on two other measurements: the electrical power to drive the display and the luminance of full-screen white. **Units:**  $\text{cd}/\text{m}^2/\text{W}$ . **Symbol:**  $e$ .

The frontal luminance efficiency is an assessment of a display system's effectiveness of turning supplied electrical power input into the output luminance under normal viewing conditions. It is not an efficiency, per se, but it is similar conceptually, something out for something in.

**SETUP:** Measurements are described in 401-1 (Power Consumption) and 302-1 (Luminance and Color of Full-Screen White).

**PROCEDURE:** Procedures found in 401-1 (Power Consumption) and 302-1 (Luminance and Color of Full-Screen White).

**ANALYSIS:** The frontal luminance efficiency  $e$  is calculated from the measured input power  $P$  and the measured luminance output  $L_w$  given by  $e = L_w / P$ . Requisite measurements are described in 401-1 (Power Consumption) and 302-1 (Luminance and Color of Full-Screen White).

**REPORTING:** Report the following on the reporting sheet: Input voltage, input current, input power, output luminance, and frontal luminance efficiency to no more than three significant figures each.

**COMMENTS:** The frontal luminance efficiency of the power-light conversion process generally takes into account all the system losses, giving a single numeric value that can be used as a figure of merit for a display as a system. Based upon the fact that it gives intuitively useful information on the amount of output (luminance) derived from an input power, it is perhaps the most useful of all display measurement parameters for correlating the effectiveness of variations within one display technology or for comparing display technologies. It also can be a valuable tool for understanding where weaknesses lie in a display system, and where improvements can be determined. For example, the frontal luminance efficiency of a backlit LCD can be affected by the efficiency of the inverter driving the backlight. Changing the inverter to one with a higher efficiency will improve the entire efficiency of the display proportionately.

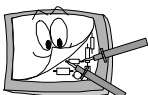
There are display devices for which frontal luminance efficiency may not be valuable as a figure of merit, such as paper-like displays or reflective displays. Correlating such displays with those intended to produce luminance output from electrical power is beyond the scope of this section. However, if we were to conceive of a comparative metric for reflective displays, we might judge reflective displays on a common ground based on task conditions. The luminance of the reflective display would have to be judged on the basis of the task illuminance. For example, consider office conditions: Given that office lighting follows the rule  $E = E_0(1 - \cos q)$ , where  $E_0 = 250 \text{ lx}$  and  $q$  is the angle the normal of the display makes with the horizontal, the maximum illuminance is  $E_{\text{max}} = 500 \text{ lx}$ . For office work, the luminance of the reflective display  $L$  under illuminance  $E$  is to be adjusted to the luminance  $L_R$  it would display under  $E_{\text{max}} = 500 \text{ lx}$ ,  $L_R = L E_{\text{max}} / E$ . Then the frontal luminance efficiency would be  $e = L_R / P$ .

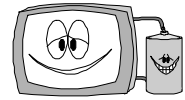
**Reporting Frontal Luminance Efficiency (FLE) – Sample Data**

Pattern Used		Full-screen white			
Input	Input Supply	Voltage, V (V)	Current, J (A)	Power, P (W)	Equation
	Panel Supply	3.32	1.36	4.50	$P_{\text{pan}} = VJ$
	Inverter Supply *	5.18	1.35	7.02	$P_{\text{inv}} = VJ^*$
	Total Power **			11.5	$P = P_{\text{pan}} + P_{\text{inv}}^*$
Output	Luminance, $L$ ( $\text{cd}/\text{m}^2$ )	73.4			$L$
Result	FLE, $e$ ( $\text{cd}/\text{m}^2/\text{W}$ )	6.37			$e = L/P$

\* If used.

\*\* Total power is sum of powers to the panel electronics, the inverter (if used) and other sources.





## 402-2 LUMINOUS EFFICACY – $h$

**DESCRIPTION:** We calculate the luminous efficacy of a full-white screen based on measurements of the luminous flux (302-9) and the power (401-1). **Units:** lm/W. **Symbol.**  $h$ .

The luminous efficacy can be somewhat misleading when applied to some FPD technologies that don't provide useful information in all directions.

**SETUP:** Measurements are described in 401-1 (Power Consumption) and 302-9 (Luminous Flux).

**PROCEDURE:** Procedures found in 401-1 (Power Consumption) and 302-9 (Luminous Flux).

**ANALYSIS:** Calculate the luminous efficacy from the input power  $P$  measured in 401-1 and the luminous flux  $F$  measured in 302-9:  $\epsilon = F/P$ .

**REPORTING:** Report the luminous efficacy to no more than three significant figures. Include the luminous flux and the power if they are not otherwise reported.

**COMMENTS:** If the power cannot be measured appropriately and cannot otherwise be adequately secured, then the luminous efficacy cannot be determined.

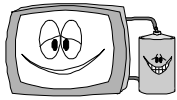
Frontal luminance efficiency!!!  
Who would be stupid enough  
to introduce a new metric?!



FPDM Working Group

ELECTRICAL





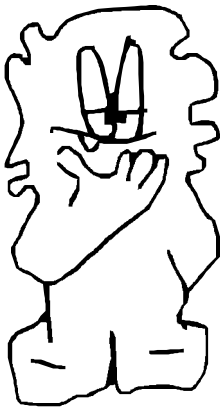
This page was intentionally left blank.



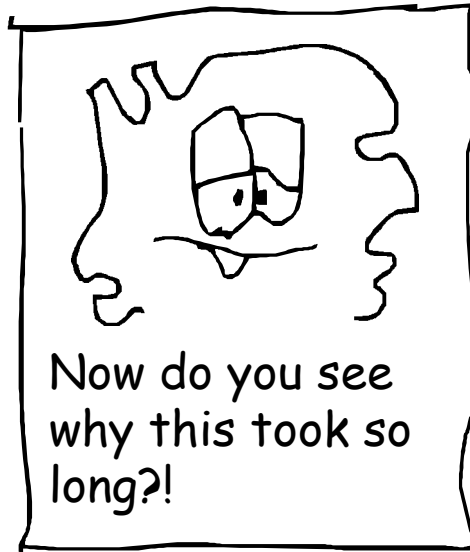
This is not a blank page. Somebody put "This page..." at the top, so it isn't blank after all.



Can we call a non-blank page a blank page in a standards document?!



Maybe we should label it some other way?



Now do you see why this took so long?!



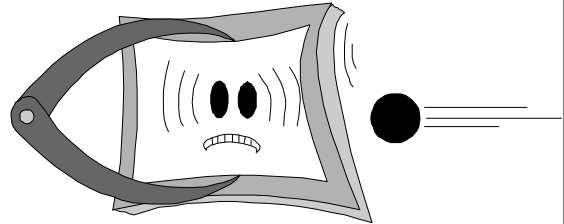
Look! A footer. Indeed, it isn't blank.

ELECTRICAL



## 500 MECHANICAL AND PHYSICAL CHARACTERISTICS

Mechanical and physical characteristics include size of the display surface, overall dimensions of the display, mounting specifications, mass (or weight), and strength. At the time of this writing, the subjects in the grayed areas were not available. They are anticipated in the next edition.



### 501 SIZE OF DISPLAY

#### 501-1 SIZE OF VIEWABLE AREA

#### 501-2 ASPECT RATIO

#### 501-3 OVERALL DIMENSIONS

#### 501-4 MOUNTING SPECIFICATIONS AND TOLERANCE

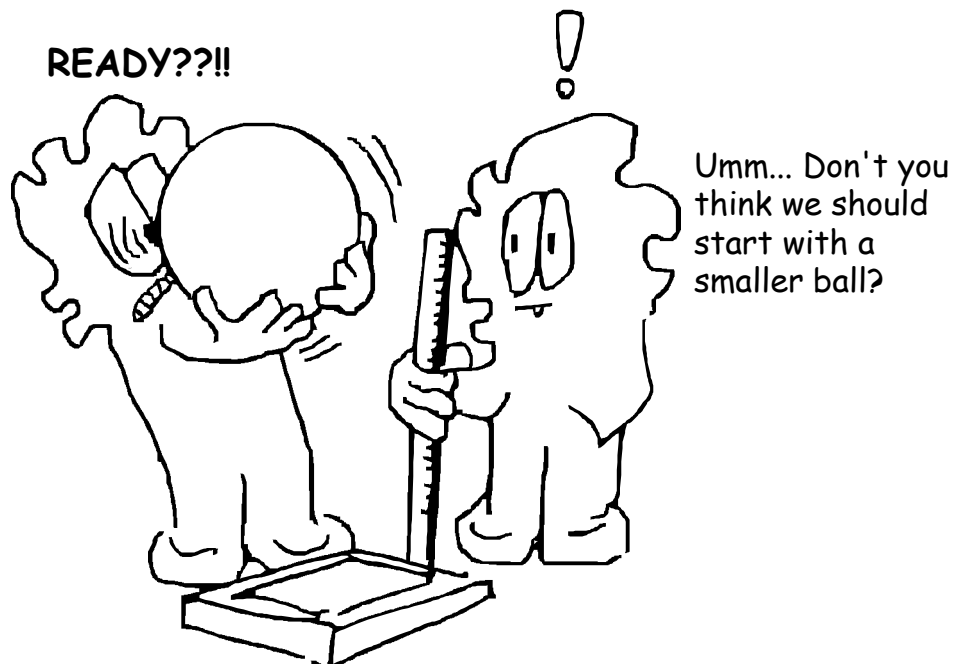
### 502 STRENGTH

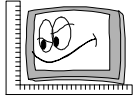
#### 502-1 TORSIONAL STRENGTH

#### 502-2 FRONT OF SCREEN STRENGTH

#### 502-3 IMPACT RESISTANCE

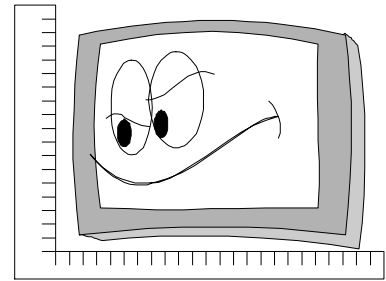
### 503 MASS (WEIGHT)





## 501 SIZE OF DISPLAY

Before there were fixed pixel displays, CRTs were the dominant display technology. CRTs have a scanned raster that can vary in position and size as a function of electrical and/or magnetic processing of a scanning electron beam. The number of pixels can also vary as a function of the rate of modulation of the electron beam across each scan line. Thus, the variability in the raster-scanned technology provided a great deal of variability for the size of a raster. Trying to establish a single diagonal value for a CRT raster which could vary significantly lead to some confusion over what the real diagonal size of the CRT display actually was. For a fixed pixel display, the pixels exist physically on a display substrate and can never vary, in size, position, or quantity. That makes it possible to establish guidelines to assure that no significant errors in expressing the diagonal size of fixed pixel displays can ever exist. If the proper guidelines are established and followed, the diagonal number can be a figure of merit for display size that is meaningful and unambiguous. Potential errors for diagonal size varying from the real pixel array diagonal are few, such as error in the exact size is due to rounding, or not addressing all pixels.



There are a number variables that relate to the sizes associated with the measurement of a FPD. We provide a list here of all the variables used in this section of the document. Many displays made have square pixels. We provide equations for both square and non-square pixels. We summarize the relationships between these variables that may be of use in Table 3 in the next section (501-1).

<b>Table of Variables Related to Size</b>	
$P_H, P_V, P$	Pixel pitch for horizontal, vertical, and for square pixels for which $P_H = P_V = P$ , expressed in units of distance per pixel (nm/pixel, mm/pixel, in/pixel, ...)
$N_H, N_V$	Number of pixels in the horizontal and vertical direction (no units)
$S_H, S_V, S$	Pixel spatial frequency for horizontal, vertical, and for square pixels ( $S = 1/P$ ), expressed in units of number of pixels per unit distance (pixels/mm, pixels/cm, pixels/in, ...)
$D$	Diagonal measure of the screen, expressed in units of distance (mm, cm, m, in, ...)
$H, V$	Horizontal and vertical measure of the screen displayable area (total area of all addressable pixels), expressed in units of distance (mm, cm, m, in, ...)
$a$	Aspect ratio $a = H/V$ (no units)
$A$	Area of viewable display surface ( $A = HV$ )
$a$	Rectangular area allocated to each pixel ( $a = P_H P_V$ )

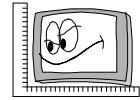
### CONTENTS:

#### 501 SIZE OF DISPLAY

##### 501-1 SIZE OF VIEWABLE AREA

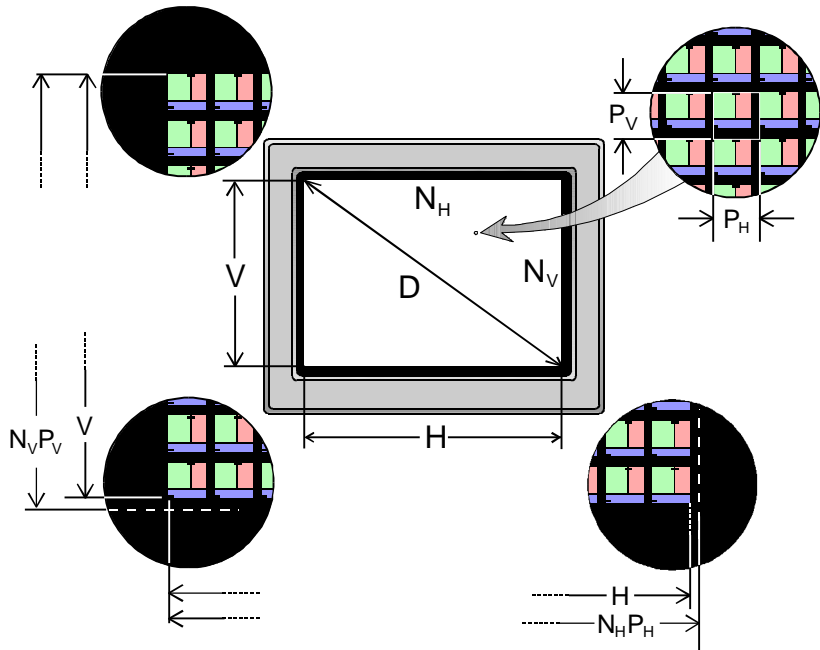
##### 501-2 ASPECT RATIO





**501-1 SIZE OF VIEWABLE AREA**

In the following it is assumed that we are referring to a fixed rectangular array of pixels used to produce information. The size of the viewable area includes only that part of the display surface which can be seen by the user of the display under normal operating conditions. Any pixels behind a bezel are not to be included. Any border that doesn't contain information-producing pixels is also not included in the viewable area. Thus, the viewable area is that group of pixels that contribute to the display of information and can be controlled. See Fig. 1. For most displays you will always know the number of horizontal pixels (or columns)  $N_H$  and the number of vertical pixels  $N_V$ .



*Fig. 1. Dimensional measurements of fixed-array display with arbitrary pixel arrangement (as an example).*



In all that follows reference is made to several measured dimensions. Should you desire to measure any of these sizes, caution is in order. **Using a ruler placed over the display may damage the surface of the display.** Further, many inexpensive rulers may not be sufficiently accurate for use, e.g., we have seen some inexpensive rulers exhibit errors of  $\pm 1$  mm over a 30 mm distance. When a ruler is used, there can be a parallax error because the surface upon which the ruler is placed can be separated from the pixel surface by usually a covering glass or plastic, and unless the eye is carefully placed along a perpendicular line from the surface over the measurement point, an error may occur because of the position of the eye. A traveling microscope or equivalent is best suited for these types of measurements.

**PIXEL FORMAT ( $N_H \times N_V$ ):** The viewable or displayed surface of a DUT comprises a rectangular array of pixels specified by having a number  $N_H$  of pixels in the horizontal direction (number of columns) and a number  $N_V$  of pixels in the vertical direction (number of rows or lines). The product of the horizontal and vertical number of pixels

$$N_T = N_H \times N_V, \quad [\text{total number of pixels}] \tag{1}$$

is the total number of pixels  $N_T$  in the DUT.

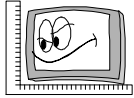
**HORIZONTAL SIZE, VERTICAL SIZE, AND AREA ( $H, V, A$ ):** The horizontal size  $H$  is the distance from the left-most part of the active pixel on the left side of any line to the right-most part of the active pixel on the right side of the same line. The product

$$A = HV. \quad [\text{area}] \tag{2}$$

is the size of the viewable area. See Fig. 1.

**PIXEL PITCH AND SPATIAL FREQUENCY ( $P_H, P_V, P, S_H, S_V, S$ ):**

The horizontal distance between a point on one pixel to the similar point on the next horizontal pixel is the horizontal pixel pitch  $P_H$ . Similarly, the vertical pitch  $P_V$  is the vertical distance between two similar points on



adjacent vertical pixels. In Fig. 1, upper right inset showing an arbitrary RGB rectangular subpixel configuration, the pixel pitch is depicted as being measured from the upper left corner of the green subpixel to the upper left corner of the adjacent green subpixel. For square pixels

$$\text{pixel pitch: } P_H = P_V = P. \quad [\text{for square pixels only}] \quad (3)$$

Associated with the pixel pitch is the spatial frequency of the pixels, often called by units such as “pixels per centimeter” or “pixels per inch.” The spatial frequency is inversely related to the pitch

$$\text{spatial frequency: } S_H = 1/P_H, \quad S_V = 1/P_V, \quad (4a)$$

$$S = 1/P. \quad [\text{for square pixels only}] \quad (4b)$$

Some use the term “dots per ...” for “pixels per ...” whereas dot most often refers to the subpixel, usage has been sloppy, and you are warned to be cautious in interpreting to what spatial frequency reference is being made when the term “dot” is used.

Given that the display has  $N_H$  horizontal pixels (or columns) and  $N_V$  vertical pixels (rows or lines) we might be tempted to claim that the size of either the horizontal or the vertical dimension of the display is simply the product of the number of pixels and the pitch in that direction. This is not exactly true, but the error is generally so small that it can be ignored—for typical desktop or laptop display applications, for example, the difference will be on the order of 100  $\mu\text{m}$ . The lower two insets in Fig. 1 show how the actual display horizontal and vertical dimensions are slightly smaller than the number of pixels times the pixel pitch. If the pixel had a 100 % fill factor then the following equations would be exact. (The pixels shown in Fig. 1 have a 52 % fill factor.)

$$\text{horizontal, vertical size: } H @ N_H P_H, \quad V @ N_V P_V; \quad [\text{all pixels}] \quad (5a)$$

$$H @ N_H P, \quad V @ N_V P. \quad [\text{for square pixels only}] \quad (5b)$$

We will generally treat and write these approximations as exact equalities in what follows with the understanding that, should the error be important, all interested parties will be made aware of the slight difference.

**AREA ALLOCATED TO A RECTANGULAR PIXEL ( $a$ ):** The rectangular matrix of pixels has a certain area associated with the containment of each pixel. The area  $a$  allocated to each pixel is simply the product of the horizontal and vertical pixel pitches

$$\text{area allocated to pixel: } a = P_H P_V, \quad [\text{all pixels}] \quad (6a)$$

$$a = P^2. \quad [\text{for square pixels only}] \quad (6b)$$

**DIAGONAL SIZE:** To describe the size of a display surface the diagonal size is presently the most common metric for specifying the viewable size of a display. The diagonal measure shall refer to only the part of the display surface that has visible pixels that can be controlled to display information;

$$\text{diagonal: } D = \sqrt{H^2 + V^2}. \quad (7)$$

There are several ways to express or calculate the diagonal depending upon what information is available. Should the pixel pitch and the number of pixels be the most reliable information, then

$$D = \sqrt{(P_H N_H)^2 + (P_V N_V)^2}, \quad [\text{all pixels}] \quad (8a)$$

$$D = P \sqrt{N_H^2 + N_V^2}. \quad [\text{for square pixels only}] \quad (8b)$$

If the pixel spatial frequency are known accurately, we can use

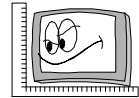
$$D = \sqrt{\left(\frac{N_H}{S_H}\right)^2 + \left(\frac{N_V}{S_V}\right)^2}, \quad [\text{all pixels}] \quad (9a)$$

$$D = \sqrt{N_H^2 + N_V^2} / S. \quad [\text{for square pixels only}] \quad (9b)$$

Caution should be exercised in assessing the uncertainty of the spatial frequency or, e.g., “dots per inch” (DPI). In general industry use, the spatial frequency (DPI) is often rounded to whole numbers and therefore may not be accurately reported.

**We recommend that the diagonal measurement be reported within  $\pm 0.5\%$  of its true value** (this includes all measurement error as well as rounding). For example, with displays used in an office or laptop environment, this recommendation amounts to requiring that the diagonal be expressed to at least the nearest





1.3 mm ( $\pm 0.5$  mm) or the nearest 1/10 in ( $\pm 0.05$  in). For calculation purposes a more precise diagonal measurement may be desired. **Note: Although rounding to no coarser than  $\pm 0.5$  % of the diagonal's size is recommended, it is always acceptable to express the diagonal to a greater precision. Expressing the diagonal with a lower precision than  $\pm 0.5$  % is not acceptable.** Examples of the worst-case errors are shown in Table 1.

Actual Diagonal	Reported Diagonal	Error
306.045..mm (12.049...in)	304.8 mm (12.0 in)	1.245 mm (.049 in)
306.072 mm (12.05 in)	37.34 mm (12.1 in)	1.27 mm (.05 in)

In Table 2 we show examples of how the diagonal might be expressed and reported.

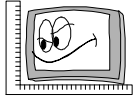
True Diagonal	Preferred	Acceptable	Not Acceptable
13.7931 in	13.8 in	13.79 in	14 in
12.0942 in	12.1 in	12.09 in	12 in
12.1253 in	12.1 in	12.13 in	12 in

**ASPECT RATIO:** This is handled in the next section (501-2). Briefly, the aspect ratio *a* is the ratio of the horizontal size to the vertical size:

$$a = H/V,$$

and may be useful in calculations. Note, however, sometimes the aspect ratio is not a precisely know quantity but is often rounded to a convenient ratio of integers, e.g.,  $4 \times 3$ ,  $16 \times 9$ , etc.





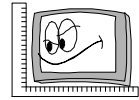
**Table 3. Summary of useful relationships between size variables.**

Some equations are only true for square pixels. See Table 4 for definitions.																	
Expression	Square Pixels ?	$N_H$	$N_V$	$N_T$	$H$	$V$	$A$	$P_H$	$P_V$	$P$	$S_H$	$S_V$	$S$	$a$	$D$	$a$	Comments
$A = HV$					*	*	*										
$H = N_H P_H$		*			*			*									Very small error
$H = \frac{D}{\sqrt{\left(\frac{N_V}{N_H}\right)^2 + 1}}$	Sq. px Only	*	*		*											*	
$H = \frac{aD}{\sqrt{a^2 + 1}}$	Sq. px Only				*											*	Aspect ratio may not be known accurately due to rounding.
$V = N_V P_V$			*			*			*								Very small error
$V = \frac{D}{\sqrt{\left(\frac{N_H}{N_V}\right)^2 + 1}}$	Sq. px Only	*	*			*										*	
$V = \frac{D}{\sqrt{a^2 + 1}}$	Sq. px Only					*										*	Aspect ratio may not be known accurately due to rounding.
$a = P_H P_V$								*	*							*	
$a = P^2$	Sq. px Only									*						*	
$a = A/N_T$				*			*									*	
$D = \sqrt{H^2 + V^2}$					*	*										*	
$D = \sqrt{(P_H N_H)^2 + (P_V N_V)^2}$		*	*					*	*							*	
$D = \sqrt{P_2(N_H^2 + N_V^2)}$	Sq. px Only	*	*							*						*	
$D = \sqrt{\left(\frac{N_H}{S_H}\right)^2 + \left(\frac{N_V}{S_V}\right)^2}$		*	*								*	*				*	
$D = \sqrt{N_H^2 + N_V^2} / S$	Sq. px Only	*	*										*			*	
$P = \frac{D}{\sqrt{N_H^2 + N_V^2}}$	Sq. px Only	*	*							*						*	
$a = H/V$					*	*											*
$a = N_H / N_V$	Sq. px Only	*	*														*

**Table 4. Variables Related to Size.**

$P_H, P_V, P$	Pixel pitch for horizontal, vertical, and for square pixels for which $P_H = P_V = P$
$N_H, N_V$	Number of pixels in the horizontal and vertical direction
$S_H, S_V, S$	Pixel spatial frequency for horizontal, vertical, and for square pixels ( $S = 1/P$ )
$D$	Diagonal measure of the screen, expressed in units of distance
$H, V$	Horizontal and vertical measure of the screen
$a$	Aspect ratio $a = H/V$
$A$	Area of viewable display surface ( $A = HV$ )
$a$	Rectangular area allocated to each pixel ( $a = P_H P_V$ )





## 501-2 ASPECT RATIO

This section describes the various methods to calculate and report the aspect ratio of a display. Generally speaking, the aspect ratio is not often considered to be a precise measure of the display, but rather an approximation of the actual width-to-height ratio in order to indicate the shape of the display surface in a simple manner. If the display surface is not square, there are two orientations in which the display can be placed. If the largest side is placed horizontally we refer to this as the **landscape** orientation. If the largest side is placed vertically we refer to this as the **portrait** orientation. Here are the variables used in this subsection:

$P_H, P_V, P$	Pixel pitch for horizontal, vertical, and for square pixels for which $P_H = P_V = P$
$N_H, N_V$	Number of pixels in the horizontal and vertical direction
$D$	Diagonal measure of the screen
$H, V$	Horizontal and vertical measure of the screen
$a$	Aspect ratio

The aspect ratio is defined as width-to-height ratio of the active viewing area of a screen:

$$a = H/V.$$

Note that this refers to the active area of the screen, the part of the observable screen viewed and addressed to display information.

Although the aspect ratio could be expressed as a decimal number, it is usually expressed as a ratio such as H:V, e.g., 4:3, 16:9, etc, with the horizontal aspect given first in the ratio. In fact, the aspect ratio is often expressed as a ratio of small integers. For example, a landscape display may have a horizontal size of 300 mm and vertical size of 200 mm, then the aspect ratio is

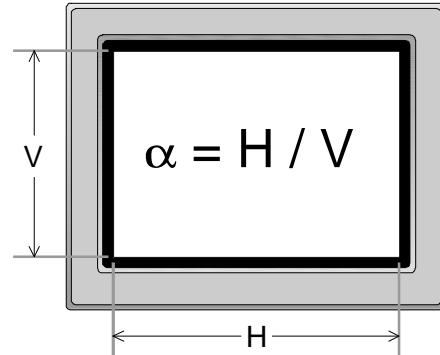
**Landscape:**  $a = H/V = 300/200 = 1.5 = 3/2$ , or expressed as a ratio, 3:2.

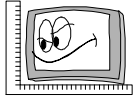
If that same display were used in the portrait orientation the aspect ratio would still be the width-to-height ratio

**Portrait:**  $a = H/V = 200/300 = 0.6667 = 2/3$ , or expressed as a ratio, 2:3.

In the above example, the greatest common divisor in for both the numerator and denominator is 100 which yields a simple integer ratio. However, suppose that instead we had a display with a horizontal size of  $H = 311$  mm and a vertical size of  $V = 203$  mm for the active addressable image producing area. The decimal value for the aspect ratio is then  $\alpha = 1.53202\dots$ . There is no common divisor for these dimensions, but we would still probably see the display listed as having an aspect ratio of 3:2 for simplification. This is why the aspect ratio when expressed as a ratio of integers cannot be relied on to always exactly specify the actual width-to-height ratio. Avoid ever using the aspect ratio as an accurate number in formulas and calculations unless you are sure it exactly expresses the ratio of  $H/V$ , in which case it will usually be expressed as a decimal value.

**Aspect Ratio Conversion Table:** If one is calculating the aspect ratio from the horizontal and vertical dimensions and a greatest common divisor cannot be obtained to reduce the ratio to a simple integer ratio, the following table is provided to help determine the closest aspect ratio expressed in integer number ratios where the integers are not greater than 20. Determine the decimal aspect ratio; then find the closest decimal aspect ratio in the table; finally, use the ratio of integers for the simplified aspect ratio. Be reasonable using the table: You may find that quoting a 12:11 aspect ratio (1.0909) is so close to 11:10 (1.1) that you would rather use 11:10; or 17:13 (1.3077) is sufficiently close to 4:3 (1.3333) that you would more reasonably use 4:3. Most of the time people used simple ratios where the integers were usually less than 10. The introduction of the 16:9 standard format for HDTV has complicated the matter, hence all the fractional aspect ratios using integers less than 20 are presented for your interest and inspection. The table assumes the landscape orientation. If the portrait orientation is used, simply invert the decimal ratio ( $1/\alpha$ ), find the appropriate integer ratio in the table, then reverse the ratio for use with the portrait orientation.





Aspect-Ratio Conversion Table							
Decimal aspect ratios less than 5:1 converted to integer ratios using integer numbers no greater than 20.							
Ratios in parentheses are some equivalent aspect ratios sometimes used in industry.							
Decimal Aspect Ratio	Integer Aspect Ratio	Decimal Aspect Ratio	Integer Aspect Ratio	Decimal Aspect Ratio	Integer Aspect Ratio	Decimal Aspect Ratio	Integer Aspect Ratio
1	1 : 1	1.2727...	14 : 11	1.7143...	12 : 7	2.6	13 : 5
1.0526...	20 : 19	1.2857...	9 : 7	1.7273...	19 : 11	2.6667...	8 : 3
1.0556...	19 : 18	1.3	13 : 10	1.75	7 : 4	2.7143...	19 : 7
1.0588...	18 : 17	1.3077...	17 : 13	1.7778...	16 : 9	2.75	11 : 4
1.0625...	17 : 16	1.3333...	4 : 3 (8:6)	1.8	9 : 5 (18:10)	2.8	14 : 5
1.0667...	16 : 15	1.3571...	19 : 14	1.8182...	20 : 11	2.8333...	17 : 6
1.0714...	15 : 14	1.3636...	15 : 11	1.8333...	11 : 6	2.8571...	20 : 7
1.0769...	14 : 13	1.375	11 : 8	1.8571...	13 : 7	3	3 : 1
1.0833...	13 : 12	1.3846...	18 : 13	1.875	15 : 8	3.1667...	19 : 6
1.0909...	12 : 11	1.4	7 : 5 (14:10)	1.8889...	17 : 9 (34:18)	3.2	16 : 5
1.1	11 : 10	1.4167...	17 : 12	1.9	19 : 10 (9.5:5)	3.25	13 : 4
1.1111...	10 : 9	1.4286...	10 : 7	2	2 : 1 (20:10)	3.3333...	10 : 3
1.1176...	19 : 17	1.4444...	13 : 9 (26:18)	2.1111...	19 : 9	3.4	17 : 5
1.1333...	17 : 15	1.4545...	16 : 11	2.125...	17 : 8	3.5	7 : 2
1.1429...	8 : 7	1.4615...	19 : 13	2.1429...	15 : 7	3.6	18 : 5
1.1538...	15 : 13	1.5	3 : 2 (6:4)	2.1667...	13 : 6	3.6667...	11 : 3
1.1667...	7 : 6	1.5385...	20 : 13	2.2	11 : 5	3.75	15 : 4
1.1765...	20 : 17	1.5455...	17 : 11	2.2222...	20 : 9	3.8	19 : 5
1.1818...	13 : 11	1.5556...	14 : 9 (28:18)	2.25	9 : 4	4	4 : 1
1.1875...	19 : 16	1.5714...	11 : 7	2.2857...	16 : 7	4.25	17 : 4
1.2	6 : 5 (12:10)	1.5833...	19 : 12	2.3333...	7 : 3	4.3333...	13 : 3
1.2143...	17 : 14	1.6	8 : 5 (16:10)	2.375	19 : 8	4.5	9 : 2
1.2222...	11 : 9 (22:18)	1.625	13 : 8	2.4286...	17 : 7	4.6667...	14 : 3
1.2308...	16 : 13	1.6364...	18 : 11	2.4	12 : 5	4.75	19 : 4
1.25	5 : 4 (10:8)	1.6667...	5 : 3	2.5	5 : 2	5	5 : 1
1.2667...	19 : 15	1.7	17 : 10 (8.5:5)	2.5714...	18 : 7		

Depending upon the quantities one has available to perform the aspect ratio calculation, here are a variety of formulae to calculate the decimal aspect ratio:  $a = H/V = N_H/N_V$ . See Table 3 of the last section (501-1) for a complete tabulation of useful relationships between variables.

Non-square pixels  

$$a = \frac{H}{V} = \frac{N_H P_H}{N_V P_V}$$

Either  

$$a = \frac{H}{V}$$

$$V = \frac{D}{\sqrt{a^2 + 1}}$$

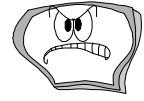
$$H = \frac{aD}{\sqrt{a^2 + 1}}$$

Square pixels  

$$a = \frac{H}{V} = \frac{N_H}{N_V}$$

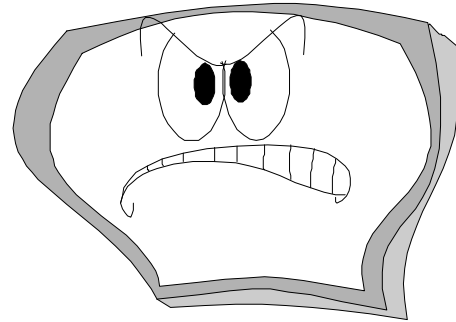
1:1
6:5
5:4
4:3
7:5
3:2
8:5
16:9
2:1
5:2
3:1
4:1
5:1





## 502 STRENGTH

It is important to note that these procedures stress the structure or surface of the display and could irreparably damage the display surface or its electronic substructure.



CONTENTS:

### 502 STRENGTH

#### 502-1 TORSIONAL STRENGTH

#### 502-2 FRONT OF SCREEN STRENGTH



## 502-1 TORSIONAL STRENGTH



(mechanical deflection, flexing, bending)

**DESCRIPTION:** We measure the torsional strength of the DUT.

Torsional strength of the display or monitor refers to its abilities to withstand uneven forces or loads, such as when it is secured in one or more places and flexed in another. This is a proof test (not a characterization) of the strength of the display to see if it survives in terms of the deflection or load when a prescribed load is applied. Although proof of the display's survival may be in terms of magnitude of displacement, this is not a force or displacement test, or a test of rigidity or flexibility. In other words, we don't deliberately stress the display to its breaking or damage point in order to find the limits of the strength, and we don't attempt to measure the deflection distance as a function of applied force. This is a pass-fail test.

With three corners of the DUT held fixed a force  $F$  is applied to the free corner until it reaches the full specified force  $F_L$ . Under such a force, the free corner of the display will experience a displacement  $p$  that should be not more than the specified maximum displacement  $p_L$ . The display meets the required torsional strength if it can withstand the full force for a specified time  $t_L$  and show a displacement of no more than  $p$ .

**SETUP:** The display assembly should be rigidly braced at any three corners and subjected to a force applied at the fourth. The contact area of the clamping fixture should be no more than 5 % of the horizontal (H) and vertical (V) size of the active area. That is, all contact regions should be  $\leq 5\%$  of any linear dimension of the active area of the screen. The test may be performed with the display either in an operating or non-operating mode as needed.

**Load Parameters:**

1. **Operating load:** (Optional) For an operating display, the force  $F_L = F_1$  is to be determined as per agreement between display integrator and manufacturer; this specification is an option.
2. **Non-operating load:** For a non-operating display, the force  $F_L = F_2$  is to be determined as per agreement between display integrator and manufacturer.
3. **Direction of load:** Perpendicular to the plane of the panel and in both directions.
4. **Test cycles:** The force test will be applied  $n$  times in each direction for each corner of the display ( $m = 2 \times 4 \times n$  cycles total for operational and non-operational tests—two sides, four corners,  $n$  applications of force).
5. **Dynamics:** Constant force for a  $t_L = 5$  s minimum duration.
6. **Clamping Force:** (Optional) If the DUT is mounted in a bezel then it may be necessary to specify a clamping force  $F_c$  when attempting to measure the deflection  $p$  of the forced corner, since some of the deflection will arise from the compression of the bezel. If the DUT does not have a protective bezel and you can attach the brace to a solid circuit board (or equivalent), then this force need not be specified.





The force may be expressed in N (newtons, generally not often used), kilogram-force (the force of gravity on a mass of one kilogram, ugh! SI is writhing in pain!), or whichever unit is mutually agreed upon by all interested parties.

**Panel Reaction to the Applied Force:** Full rated load is attained and the corner of the display is flexed not more than the specified maximum deflection distance  $p_L$  while the full rated load is applied. Prepare to measure the applied force  $F$  and the resulting deflection of the screen  $p$ .

1. **Withstand:** Each tested corner of the display is able to withstand the full-load force  $F_L$  for  $n$  times in each direction for a duration of  $t_L$  each time.
2. **Deflection:** Under the application of the full-load force each tested corner must deflect in the direction of the force by no more than the maximum deflection distance  $p_L$ .

**PROCEDURE:** Clamp the DUT rigidly at three corners. Note the original position of the corner  $z_0$  without a force applied. Gradually apply a force to the free corner until the full-load force  $F_L$  is attained. Hold that force for a duration time of  $t_L$ , measure the new position of the corner  $z$ , and calculate the deflection  $p = z - z_0$  from the corner's position before the force is applied. Then gradually release the force. Repeat application and removal of the force  $n$  times. Repeat the procedure for the opposite direction of application of the force. Repeat this procedure for each corner of the DUT.

**ANALYSIS:** Calculation of deflection during the course of the measurement:  $p = z - z_0$ . Determine the maximum deflection  $p_{max}$  for each corner for both directions and all applications of the force.

**REPORTING:** Report all measurement conditions and results.

**COMMENTS:** The parameters of this measurement are to be determined by all interested parties (display integrator and manufacturer).

**CAUTION:** This can be destructive test. It may permanently alter or destroy the display. Breakage of the display can potentially result in exposing materials that may be hazardous to health.

Reporting – Sample Data				
Parameter	Size of parameter		Units	
Full-load force, $F_L$	6		kg-orce	
Operating or non-operating	on-Op.		– none –	
Number of applications, $n$	5		– none –	
Duration of application, $t_L$	5		s	
Deflection maximum, $p_L$	7		mm	
Corner	Upper Left	Upper Right	Lower Left	Lower Right
Maximum deflection $p_{max}$	4	6	5	3
Strength verified all corners:	es	es	es	es

Variable List for Torsional Strength	
<i>Parameters Values Mutually Agreed to By All Interested Parties</i>	
$F$	Force applied perpendicularly to the display' corner
$F_L$	Full-load force to be applied to one corner at a time
$F_L = F_1$	Force on corner while display is operating (optional)
$F_L = F_2$	Force on corner white display is not operating
$t_L$	Minimum duration of full-load application $F_L$
$n$	Number of times force is applied in each direction
$m$	Total number of applications of $F_L$ , $m = 2 \times 4 \times n$
$p_L$	Maximum deflection specified for application of $F_L$
$p_{max}$	Maximum measured deflection for each corner
$p$	Deflection for application of $F_L$
$z_0$	Starting position of corner before force is applied
$z$	Final position of corner during the application of $F_L$





## 502-2 FRONT-OF-SCREEN STRENGTH

(point load)



**NOTE:** This is potentially a destructive test. It may permanently alter or destroy the display.

**DESCRIPTION:** We measure the front of screen strength by applying a specified force to the center of the screen with a simulated finger to determine if the display suffers any damage.



**SETUP:** Unless otherwise specified, the DUT should be rigidly braced at the four corners with each support covering not more than 5 % of the horizontal  $H$  and vertical  $V$  dimensions of the DUT. The displayed pattern should be static and have a video content that produces the greatest sensitivity to the applied force at the center of the screen. The force should be applied at the center of the screen within  $\pm 3$  % of the screen diagonal.

### Load Parameters:

1. **Loading finger contact surface area:**  $a = 10 \text{ mm} \pm 1 \text{ mm}$  diameter
2. **Loading finger contact material:** Elastomer of Shore 60A  $\pm 10$  durometer
3. **Applied force:** The full-load force  $F_L$  applied to the center of the screen with the simulated finger. Applied gradually to reach  $F_L$  within no shorter than 0.5 s and no longer than 10 s, held for  $t_L$ , then released within no shorter than 0.5 s and no longer than 10 s.
4. **Angle of application:** Perpendicular to the face of the display
5. **Probe tip geometry:** Hemispherical
6. **Applied pressure duration:** The time interval  $t_L$  over which the DUT is subjected to full load force  $F_L$ .
7. **Dynamics:** Single application of constant force  $F_L$  for duration  $t_L$ .

**Display Reaction to the Applied Force:** The type of damage or degradation that is unacceptable is to be determined between display integrator and manufacturer—all interested parties. Examples of types of damage would be physical breakage, discoloration of any image, or any permanent remnants of the force having been applied.

1. **Acceptable Performance:** Specification of performance after the force has been removed and after the recovery time period has passed. Damage or degradation tolerance of any displayed image due to front of panel displacement under pressure must be specified under agreement by interested parties.
2. **Recovery Time:** Recovery time  $t_R$  after the force is removed for the display to return to an acceptable performance.

**PROCEDURE:** Apply the force  $F_L$  to the center of the screen for a period  $t_L$  and then remove it (see above specifications in Setup). Wait for the recovery time  $t_R$  to elapse and inspect the screen for acceptability.

Reporting – Sample Data		
Parameter	Size of parameter	Units
Full-load force, $F_L$	6	kg-orce
Duration of application, $t_L$	5	s
Recovery time specified, $t_R$	10	s
Center strength criterion met?	es	

**ANALYSIS:** None, other than observation of the screen after the force is removed.

**REPORTING:** Report all characteristics of the test and the display.

**COMMENTS: CAUTION:** This can be destructive test. It may permanently alter or destroy the display. Breakage of the display can potentially result in exposing materials that may be hazardous to health.

Variable List for Front-of-Screen Strength	
<i>Parameters Values Mutually Agreed to By All Interested Parties</i>	
$F_L$	Full-load force applied to center screen
$t_L$	Minimum duration of full-load application $F_L$
$t_R$	Minimum recovery time after application of $F_L$



## APPENDIX

The appendix is divided into five sections:

### A100 METROLOGY

A full discussion of problems and diagnostics on making measurements plus other useful tidbits.

### A200 TECHNICAL DISCUSSIONS

Material to assist you with gaining familiarity with some of the units of colorimetry and other topics of interest.

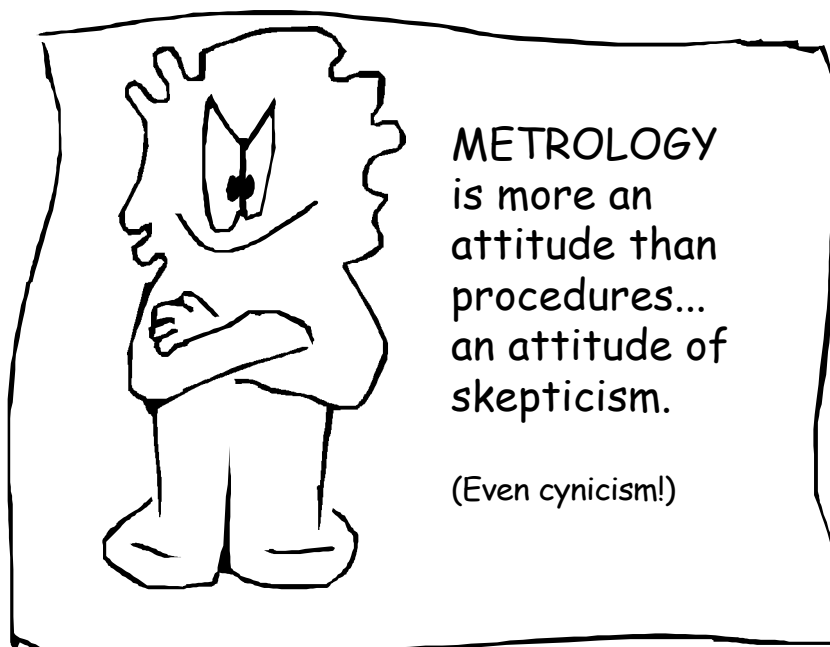
### A300 GLOSSARY, DEFINITIONS, ETC.

Alphabetized listing including variables. At the end is a tabular list of variables.

### A400 REFERENCES

### A500 TABLES AND FORMULAS

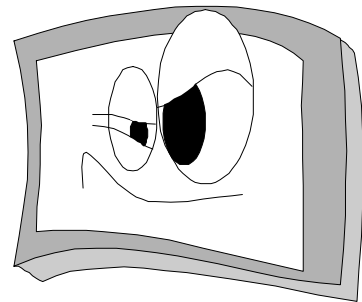
Some of the important or useful tables and formulas found in the body of this document are repeated here for your immediate reference.



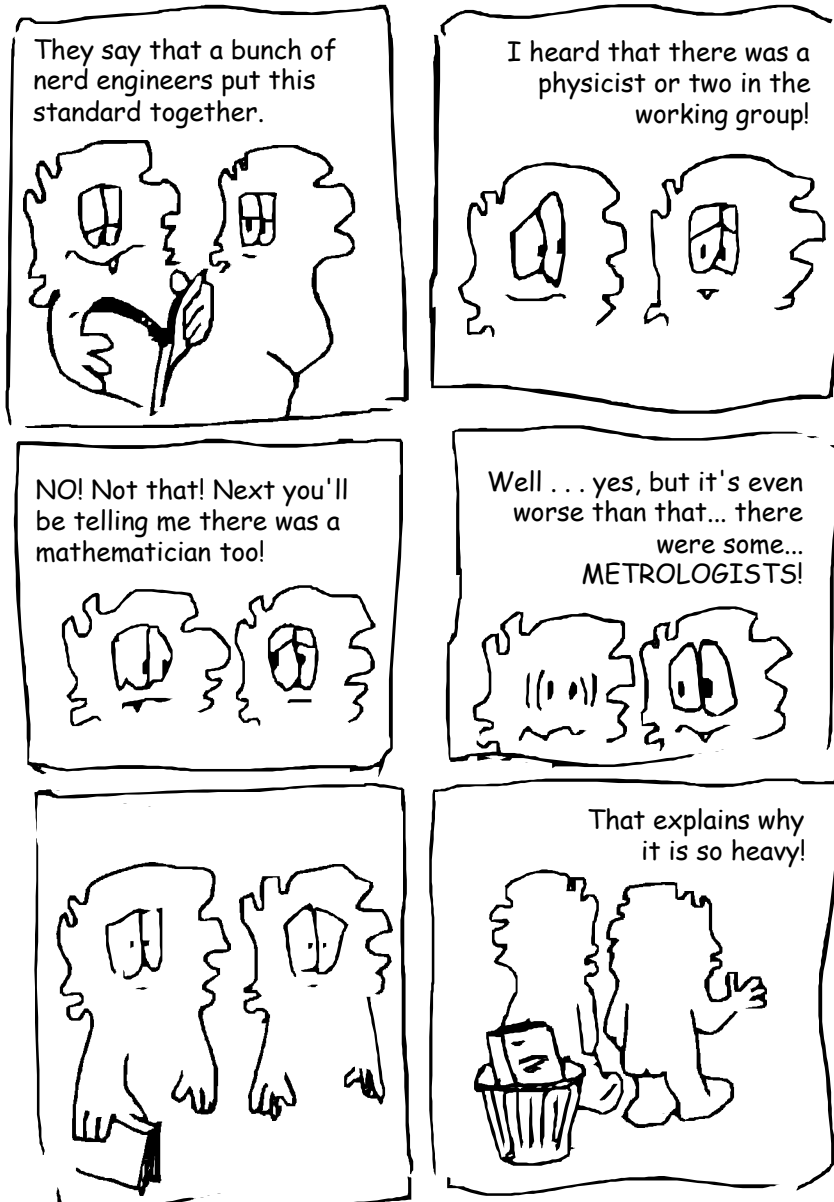


# A100 METROLOGY

Good metrology is one of the main concerns of this document. Good metrology requires attention to detail and involves a critical regard for all your measurement efforts. We attempt to alert you to some of the problems that can occur in making measurements, e.g., many are not familiar with the serious potential for corruption of the measurement from lens flare or veiling glare (A101). Another feature of this section is an attempt to provide some diagnostics to help determine if your measurement apparatus is working properly as you expect it should. We hope you find it useful.



METROLOGY





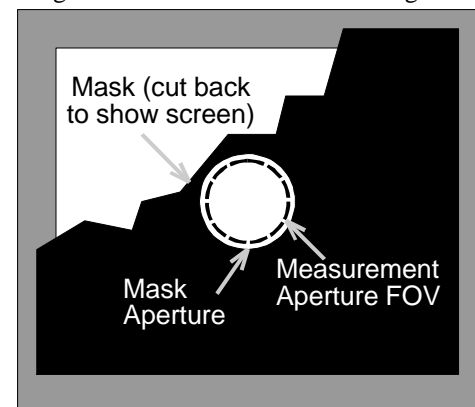
## A101 VEILING GLARE AND LENS FLARE ERRORS

The accuracy of any luminance or color measurement can be compromised by light reflected within the lens (between the glass surfaces), dirt or dust along the light-ray paths that scatters light, and reflections off of stops, the iris, the sides of the lenses and any other part of the lens system. The effect of this stray light is called veiling glare or lens flare. Often lens flare refers to the bright reflections found in the image plane which are very distinct and arise primarily because of reflections back and forth on the lenses surfaces (as when a camera points in the direction of the sun and bright multicolored reflections are observed). Veiling glare often refers to the stray light that floods the entire image area and is not as noticeable because of its quasi-uniformity. Veiling glare is particularly observable when attempting to measure dark areas on the screen when bright areas are also present on the screen. Even our eyes, although having extraordinary capabilities, can also have glare problems such as when the bright lights of an on-coming automobile causes an obscuration of the road, or when looking at a sunset we have difficulty seeing shadow details. (By the way, if you are wearing glasses, you will want to remove them before attempting to appreciate any high contrast object—they can introduce quite a bit of glare.) The effects of veiling glare are not limited to measurements of black with white in the vicinity. Errors can also be introduced in measuring bright areas and colors. The amount of veiling glare is very dependent upon the lens system used. Errors as high as a few percent in measurements of white have been observed depending upon conditions. Because of glare, serious errors of hundreds of percent can be introduced into black measurements when white is present on the screen.

There are two regimes that are of interest: Large-area measurements and small-area measurements. Making accurate large-area measurements of luminance is straightforward when a proper mask is employed. Making accurate small-area measurements of dark areas when bright areas are present can be very challenging. We first discuss the large area contrast measurement, then provide some pointers on how one can deal with small-area measurements. Often we speak of contrast as a metric of interest. There may be metrics that offer a better rendering of the visual perception of the contrast than the contrast ratio. Contrast is not the only metric affected by glare either. All measurements can be corrupted by glare, but glare is particularly damaging to measurements of black.

### A101-1 Avoiding Glare in Large Area Measurements

The simplest way to avoid veiling glare is to mask off the region being measured so that most of the light exposed to the lens system is the light being measured. Figure 1 shows a rectangular mask (cut away to show the screen) which is 10 % larger than the round area measured by the LMD. However, there are cautions in using masks. We don't want the mask to affect the display being measured. That is, we don't want the mask to reflect light back onto the display so the measurement is affected by the reflections from the mask. A variety of flat, rectangular masks have been used such as black paper, black gloss plastic, black matte plastic (preferred over black gloss plastic for a flat mask used near the screen), black flocked paper (has something like a thin black velvet coating), and black felt. If the display surface is rugged enough to accommodate it, even black masking tape has been used. However, the flat masks are effective especially when they can be placed very near or on the pixel surface. When they must be displaced from the pixel surface, the flat mask can reflect light back onto the display surface that can corrupt the measurement. A displacement of the flat mask from the surface may arise either by a covering glass on the display surface, the measurement system restrictions, or the delicate nature of a prototype display that will not tolerate the mask touching its surface. If a flat mask must be used, black felt fabric is often the best material to use. There also may be another problem in using flat masks directly on the screen: The cooling properties of the screen may be affected, the screen may get warmer, and its properties may be affected accordingly. To get around some of these problems a method of using a cone mask is presented below. But first, it is instructive to examine a diagnostic.



*Fig. 1. Mask 10% larger than measurement aperture reduces effects of veiling glare.*



### A. Black Glossy Cone Masks

A gloss-black cone mask (see construction specifications below) can also be used to restrict much of the unwanted light from entering the LMD, see Figs. 2, 3, and 4. To avoid light from the rest of the display being reflected onto the viewing area and to avoid the light from other parts of the screen reflecting off the interior of the cone and into the lens, the apex angle of the cone should be  $90^\circ$  ( $45^\circ$  each side of the optical axis of the LMD and the symmetry axis of the cone). So that the edge surface of the cone will not obscure any of the measured area (producing a vignette), the cone must be placed close enough to the display surface so that the inequality shown in Fig. 2 is satisfied:  $z < z_{\max} = d(s - u) / (w - u)$ , where  $z$  is the distance of the edge of the aperture of the cone from the display surface,  $u$  is the size of the display surface measured by the LMD,  $w$  is the width of the LMD lens aperture (entrance pupil),  $d$  is the distance the LMD lens is from the display surface, and  $s$  is the size of the aperture of the cone. In practice,  $z$  will be usually less than the limit expressed by the inequality so that the cone will not inadvertently obscure any of the area viewed. This requirement on  $z$  arises from insisting that all light rays from the region viewed by the LMD can enter the LMD. As much as possible, all bright areas on the display should be outside of the region denoted by  $p$  in Fig. 2, where  $p = [z(s + w)/(d - z)] + s$ .

The outer diameter of the cone should be sufficient to prevent light from the edges of the screen from entering the lens of the LMD. In the case of large displays where it would be impractical to make a single cone with sufficient outer diameter, try a second cone or flat mask where the hole is larger than the diameter of the lens of the LMD. The second mask is nearer the LMD and obscures the large area of the display but permits a clear view of the cone placed nearer the display through which the measurement is made. Whatever you do, think in terms of how reflections can corrupt the measurement.

The edge of the cone nearest the FOV is not ever perfect, so some light can scatter from the edge into the

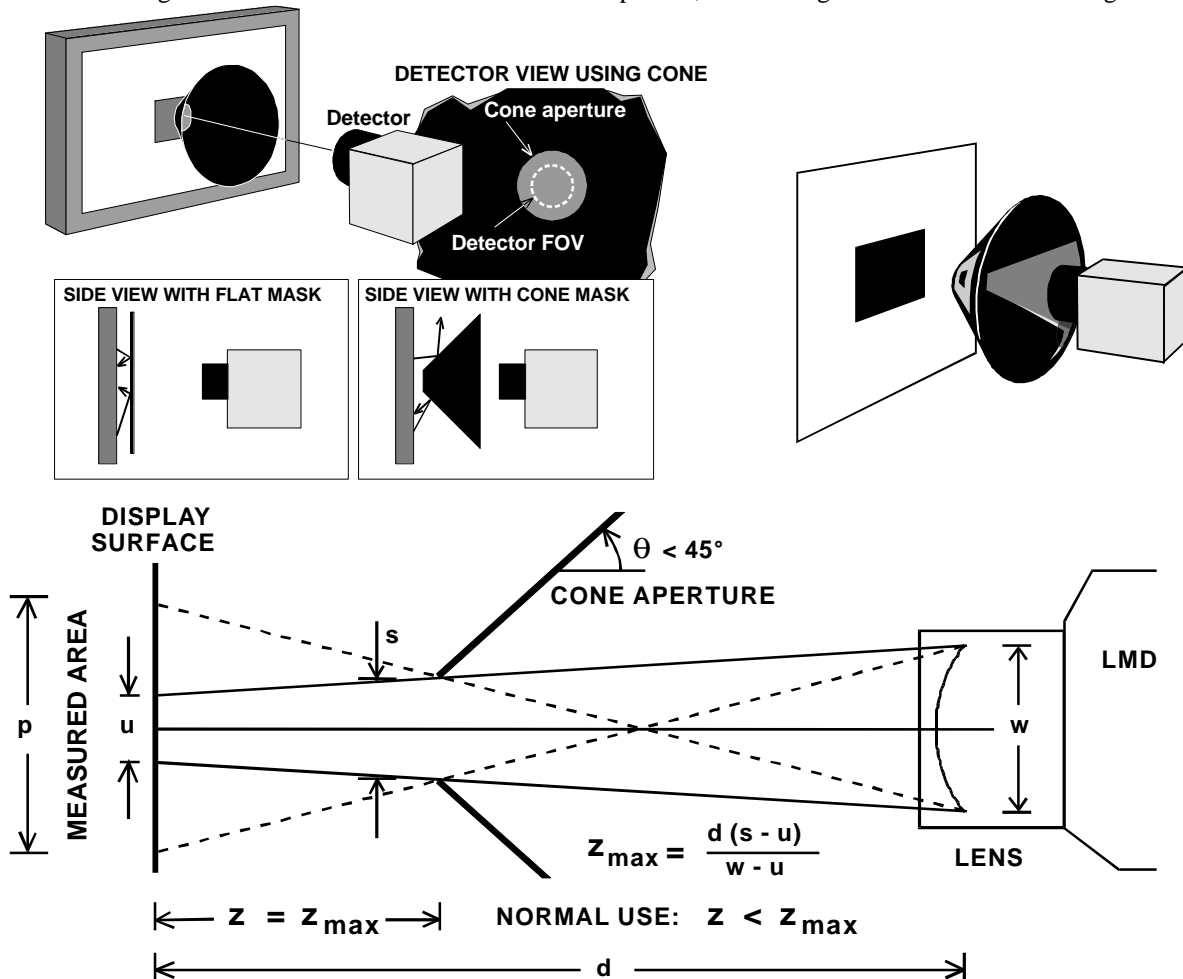


Fig. 2. Use of gloss-black cone mask to shield the lens of the LMD from bright parts of the display surface.



LMD. Additionally, diffraction can contribute to the stray light especially when the cone aperture diameters get very small, a situation in which the edge scattering is also relatively great. Cones have been successfully used with apertures down to 5 mm.

**Diagnostic for Cone Mask Effectiveness:** The following is a diagnostic for testing how well the cone masks eliminate glare. What this amounts to is a more detailed investigation of the use of the cone, and can be ignored unless you are particularly interested: The success of the addition of the cone to improving the measurement of contrast can be tested by viewing a gloss-black disk placed on a glass plate at the exit port of a uniform light source having the same maximum luminance as the display  $L_{\text{test}} \equiv L_w (\pm 20 \%)$ ; we will call this the cone test target (CTT) – see Fig. 3. The disk should have a diameter of approximately  $p$  (-0 %, +20 %). A comparison of the luminance measurement of the disk with and without the cone present will provide an indication of the effects of lens flare. (This is similar to the CIE diagnostic mentioned below.) To better understand the effects of the cone on the measurement, perform the following procedure: The CTT is brought up to just touch the edge of the cone, and the luminance  $L$  is measured as a function of distance of the CTT from the edge of the cone, that is, obtain  $L(z)$  for the target disk without changing the distance between the LMD and the cone. This will provide you with a better understanding of the use of the cone. The amount of luminance measured when the cone is at the selected position  $z_{\text{sel}}$  from the disk provides an upper bound on the minimum luminance that the LMD can measure with this cone arrangement when it is necessary to measure the luminance of dark areas while bright areas exist on the display surface. This measurement also permits an estimation of a limiting contrast ratio  $C_{\text{limit}}$  that the system can attempt to measure when light and dark areas coexist on the display surface in proximity such as white areas within a distance  $p/2$  of the black measurement area  $u$ :  $C_{\text{limit}} \equiv L_{\text{test}} / L(z_{\text{sel}})$ .

## B. Diagnostic for LMD Glare Corruption Determinations

Figure 1 also suggests a method of checking how much glare affects your measurement: Use a gloss-black cone mask near the screen (or a flat matte-black mask placed on a screen provided your screen will permit such handling) that has an aperture (FOV) which is 10 % larger than the diameter of the area measured by the LMD (if 10 % is difficult to use, try 20 %; the increased size of the mask aperture makes it a little easier to get the measurement aperture within the mask aperture). Measure the luminance of a white full screen with  $L_m$  and without  $L_w$  the mask. Provided the area measured is accurately indicated by the viewfinder and that measured area is placed as well as possible at the center of the aperture of the mask, the quantity  $(L_w - L_m) / L_m$  expressed in percent is one measure of the glare problems of the LMD for that application. Here  $L_w$  is the luminance of the white screen without the mask, and  $L_m$  is the luminance of the white screen with the mask in place. In general, the size of the screen should be at least ten times the size of the measurement aperture FOV, if at all possible. If you wanted to make a reproducible measurement of the glare of a system, limit the size of the screen exposing the LMD without

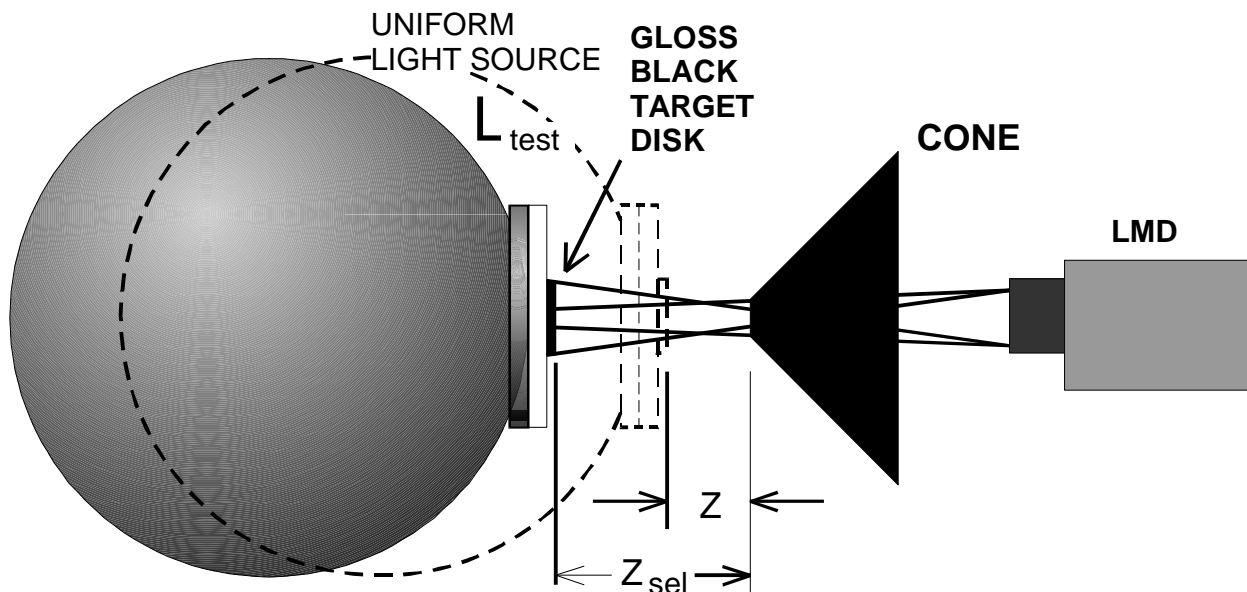


Fig. 3. Method to estimate significance of stray light as a function of position from target disk.



the aperture mask by another large-diameter mask which has a round hole having a diameter of exactly ten measurement aperture widths (10×FOV).

To readily see how black measurements can be contaminated, the CIE specifies a somewhat similar measurement to characterize the glare: They call for a uniform light source (such as the exit port of an integrating sphere) with a diameter ten times the measurement aperture. [6] A black gloss light trap (see A113) with a diameter 10 % larger than the measurement aperture is placed at the center of the light source in such a way that it doesn't change the luminance of the source. A flat piece of black opaque material will often do adequately if the reflections from the lab and the LMD do not affect the luminance of the black material. The luminance of the uniform source is measured with the trap  $L_t$  and without the trap  $L_s$  in place. The glare is defined as  $L_t/L_s$  and can be expressed in percent. The differences between the two glare diagnostic methods are that in the first method the luminance levels measured and compared are all approximately the same level; whereas with the CIE method the amount of glare is measured directly, and it assumes that the LMD is adequate for the much smaller luminance measurement. Conversely, our method prescribed above is only useful for LMDs that have sufficient precision so that the difference  $L_w - L_m$  is meaningful.

**C. Cone Construction**

A cone can easily be constructed from thin black vinyl plastic with a gloss surface on each side, see Fig. 4. Good results can be obtained with vinyl plastic 0.25 mm (0.010 in) thick (it's easy to cut with scissors or a knife). Given the size of the aperture  $d_1 = 2r_1$ , the outer diameter of the cone  $d_2 = 2r_2$ , and the apex angle  $b$  related to its complementary angle  $f$  by  $f + b/2 = p/2$ ; we want to know how to cut the proper shape from a flat sheet of plastic. We need the inner flat radius  $R_1$ , the outer flat radius  $R_2$ , and the flat-angle subtended  $q$ . We can express several relationships: The length of the side can be expressed in terms of the flat radii  $w = R_2 - R_1$ , which can also be expressed in terms of the assembled radii  $w \cos \phi = r_2 - r_1$ . The circumferences can be expressed in terms of both types of radii:  $C_1 = 2\pi r_1 = R_1 q$  and  $C_2 = 2\pi r_2 = R_2 q$ . The simplest expressions for  $R_1$ ,  $R_2$ , and  $q$  are:

$$R_1 = \frac{r_1}{\cos f}, \quad R_2 = \frac{r_2}{\cos f}, \quad q = 2p \cos f;$$

and for  $f = 45^\circ$ ,  $\cos f = 1/\sqrt{2}$ ,

$$R_1 = \sqrt{2} r_1, \quad R_2 = \sqrt{2} r_2, \quad q = p \sqrt{2},$$

with assembled cone radii  $r_1$  and  $r_2$  specified. When cutting the sheet, use scissors or a knife to assure that the edges are also at  $45^\circ$  to the display surface when the cone is assembled.

The straight ends of the cutout piece are butted together to make the cone. There are several ways to secure the edges together. One way is to clamp the butted edges together flat on a table (with the clamp holding the edges together at the middle of the straight edges) Place a small amount of quick-hardening epoxy over the exposed butted edges to hold them together. After it hardens, remove the clamp and epoxy a narrow piece of the plastic along the butted edges on the inside of the cone to seal any light leaks from small gaps. The clamp may be useful to hold the strip in place until the epoxy is secure. Be careful not to epoxy the cone to the table (you can use a non-stick surface like polyethylene or polytetrafluoroethylene [PTFE]). It may take a little compression of the cone (bending or squishing it) in order to provide a circular hole. A series of cones can be made that are small, with  $d_1$  from 5 mm to 20 mm or more and  $d_2$  approximately 60 mm. These will fit in a larger cone with  $d_1$  of 50 mm and  $d_2$  as large as needed to obscure light from the display onto the LMD lens or aperture. You can use a small piece of black tape on the inside of the larger cone to secure the smaller cone within the larger.

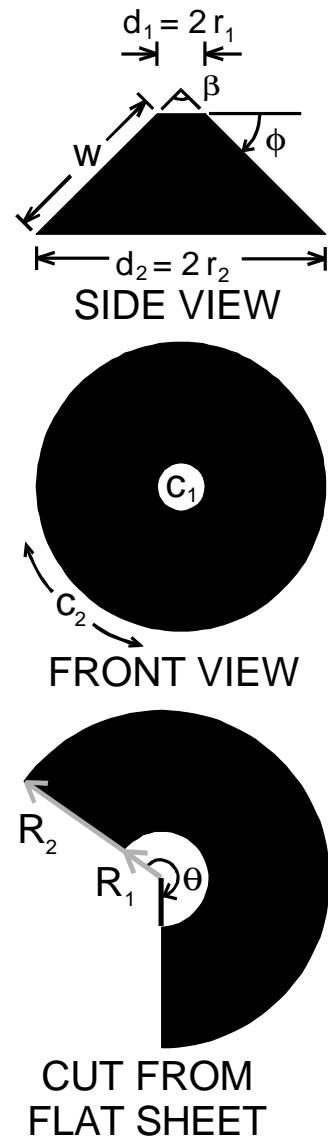


Fig. 4. Cone construction parameters.



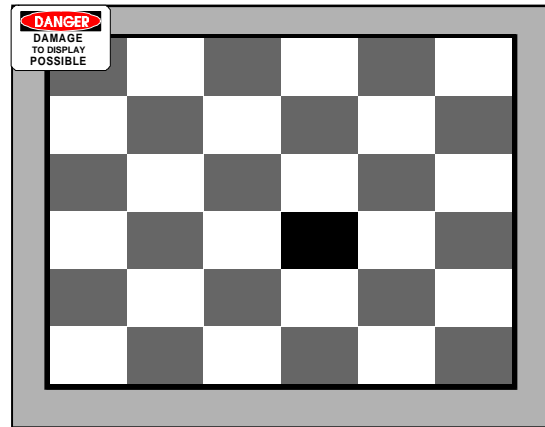
## D. Correcting for Glare with a Replica Mask

**DANGER: SOME DISPLAY SURFACES CANNOT BE TOUCHED. BE CAREFUL! BE SURE YOU CAN TOUCH THE SCREEN BEFORE PLACING ANYTHING ON THE SCREEN SURFACE.** See part (2) for obtaining a correction for use with a delicate (untouchable) surface.

(1) **Rugged Display Surface:** Should an aperture mask not be convenient to use, it is possible to approximately correct for the glare by making a black-opaque mask that is the same size as the area of black intended to be measured—a replica mask—such as a black rectangle in a checkerboard pattern. See Fig. 5. Provided that the room and LMD are not highly reflecting, a gloss-black material is best, but in most cases the kind of black material used is not an issue for these large area replica mask measurements. In principle, this method is the similar to the method described directly below (A101-2). Let  $L_g$  be the luminance of the black-opaque mask when covering the black region to be measured. This  $L_g$  is the luminance of the veiling glare contamination. Let  $L_d$  be the luminance of the black (dark) region without the mask, and  $L_h$  be the luminance of the surrounding white (high). The corrected white measurement is  $L_w = L_h - L_g$  (which will usually be a small correction) and for black,  $L_b = L_d - L_g$ . An approximate measure of the true contrast of white to black is  $C_r = L_w/L_b = (L_h - L_g)/(L_d - L_g)$ . This is not necessarily a very precise way to measure the true black value since the localized glare in the region of the covering mask is usually not uniform across the mask. The cone aperture mask is a much better way to make a high-contrast large-area measurement when it can be used.

(2) **Delicate Display Surface:** If the display surface is delicate so that you cannot touch the surface, much less secure a small target on the screen; you might try to place a piece of glass a few millimeters in front of the display but not touching the display. Then secure the replica mask on the glass. The glass should be large enough to cover the regions being measured. Watch out for reflections off the glass surface. The problem might be that you will not be able to focus well on both the replica mask and the pixel screen if you are using an array detector. If you don't dare to use anything near the screen for fear of harming the surface, you can try to make a substitute display and obtain a correction to the black measurement performed on the DUT. In this case it is helpful to have a light source (such as a backlight or other source having approximately the same area as the display to be measured) to which a black pattern of the same size as that to be measured is secured—the entire black pattern on the DUT. Let the white source luminance surrounding the mask parts be  $L_s$  and the luminance of the center of the black mask is  $L_g$ . The correction to be made on a black measurement  $L_d$  of the same black pattern surrounded by white  $L_h$  on a display surface is  $L_b = L_d - L_h L_g/L_s$ , where  $L_b$  is the corrected black luminance. If the correction  $L_h L_g/L_s$  is a few percent of  $L_h$ , then it is reasonable to make a correction to any white luminance as well:

$$L_w = L_h (1 - L_g/L_s).$$



**Fig. 5.** A checkerboard pattern is measured using a replica mask. The black pixel rectangle to be measured is above and to the left. The replica mask of the same size is the rectangle beneath and to the right of center.



## A101-2 Accounting for Glare in Small-Area Measurements



**DANGER: SOME DISPLAY SURFACES CANNOT BE TOUCHED WITHOUT SERIOUS DAMAGE. BE CAREFUL! BE SURE YOU MAY TOUCH THE SCREEN BEFORE PLACING ANYTHING ON THE SCREEN SURFACE.**

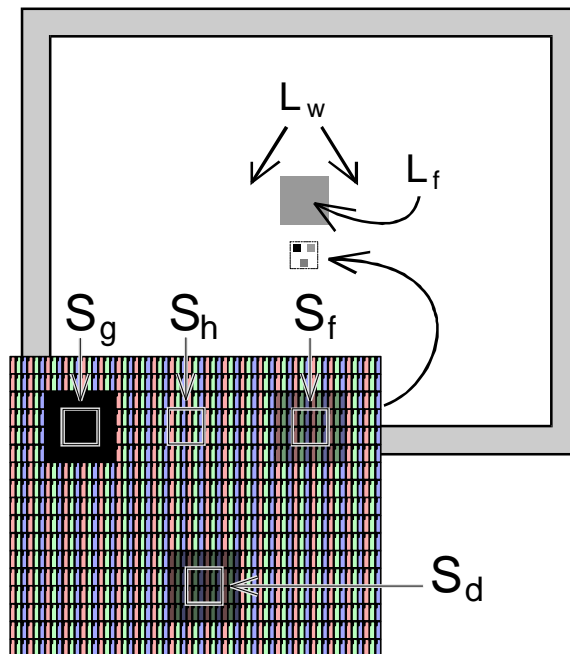
For measuring small areas on the screen it is not possible to employ a cone mask as described above for two main reasons: (1) The imperfect edge of the mask reflects too much light into the lens and back onto the screen (the ratio of the circumference to the area of a circle,  $2/r$ , gets larger as the radius gets smaller), and (2) for very small holes diffraction can be sufficient to corrupt the measurement. Not only luminance measurements can be affected by these problems. If there are multiple colors on the screen, then they can be similarly mixed to some extent by glare and reflections. This can affect the accurate measurements of chromaticity.

Keep in mind that glare generated within the optical system is not the only source of corruption of black (and white for that matter). Moderate magnifications are often needed for measuring, at the pixel level, individual black characters or lines on an otherwise white screen. Such optical systems often require a lens and holder in close proximity to the area of the display being measured. In such cases there is a risk that the instrumentation can reflect light from the white areas of the screen back onto the screen thereby especially corrupting the black measurements.

### A. Replica Masks and Diagnostics

Figure 6 illustrates the concept of an opaque black replica mask and a filter replica mask for a diagnostic tool. The exploded view shows the pixel detail of the rectangular area containing three squares. It could be a high-magnification image obtained from a CCD array LMD: The bottom center square is a  $4 \times 4$  pixel area where the pixels are black—this is what we want to measure accurately. The top left square is a piece of black mask material cut to the same size as the  $4 \times 4$  pixel area—a replica of the black area on the screen. The top right square is also a replica mask the same size as the  $4 \times 4$  pixel area, but it is made from a clear neutral-density (gray) filter material having a density of 1.0 or greater (transmission of 1 % or less) and is placed over a white area of the screen. We measure the white pixel area  $S_h$ , and the centers of each square:  $S_g$  for the opaque mask,  $S_f$  for the filter, and  $S_d$  for the black (dark) pixels. If possible, try to measure increments of full pixels. When using an array detector, experience seems to favor having a sufficient magnification so that 20 or more *detector* pixels span the minimum size of the black area, in this case the width of a  $4 \times 4$  pixel square. The presence of the filter serves a check, a diagnostic. If you cannot measure the attenuation of a filter properly, then your measurement using the mask will be in question.

Admittedly, it sometimes is not easy to cut either the opaque mask material or the plastic filter material to the same size as the pixel area being measured, particularly if the area is small. However, every attempt should be made to cut the replica masks and filters to within 10 % of the smallest linear dimension of the black pixel area. The idea behind the replica mask is that whatever light is measured in the replica mask is due to glare from the imaging system—the replica mask should, ideally, be absolutely black, and is not because of glare. Since the **size and shape** of the replica mask is the same as the black-pixel area being measured, then it would seem reasonable to expect that the glare measured in the replica mask is the same as the glare added to the black pixel area. It should be remembered that the replica mask (and filter) should be **separated** a distance from the black area so that they don't interfere significantly with each other by changing the glare characteristics of the imaging system. How



**Fig. 6.** Use of plastic filter material to serve as a diagnostic to determine if replica mask technique is working properly.



far they should be separated is hard to say, but they should be separated at least by two full widths of the minimum size of the black region to be measured.

The material used for the replica mask can be important. Gloss-black plastic works well provided that the glossy surface is not reflecting any light from surrounding objects into the lens. Since the filter also has a glossy surface, reflections must be controlled as much as possible. Any unwanted reflection off of these glossy surfaces are usually not readily visible to the eye, but they will show up in an inaccurate measurement of the transmission of the filter replica mask. There is a problem with using plastic filter material. Most such materials have a non-trivial **temperature coefficient**. Thus, the filter material must be calibrated for the temperature conditions of the screen. To solve this problem, use a large piece of filter material placed on the screen that can be measured with a LMD and a cone mask (shown above the inset area in Fig. 6). After the filter material has warmed up to the display surface temperature, measure the luminance of the filter  $L_f$ . Then measure the luminance of the screen on each side of the filter and average those results  $L_w$ . The **transmission** of the filter material is then  $T = L_f/L_w$ . When you measure the transmission of the filter material used for the small area replica mask  $T' = (S_f - S_g)/(S_h - S_g)$  and you obtain a value close to  $T$  (within 5 % is good), then you can feel confident of your technique, and proceed with the glare correction of black. The **black** level is determined by  $S_b = S_d - S_g$ . The **white** level is  $S_w = S_h - S_g$ . And the **contrast** is  $C = S_w/S_b$ . This corrected contrast should be significantly larger than the uncorrected contrast  $S_h/S_d$ . To obtain luminance values for the black and white measurements, the LMD must be calibrated for luminance measurements—see A111 Array Detector Measurements.

## B. Line Replica Mask on Rugged Surfaces

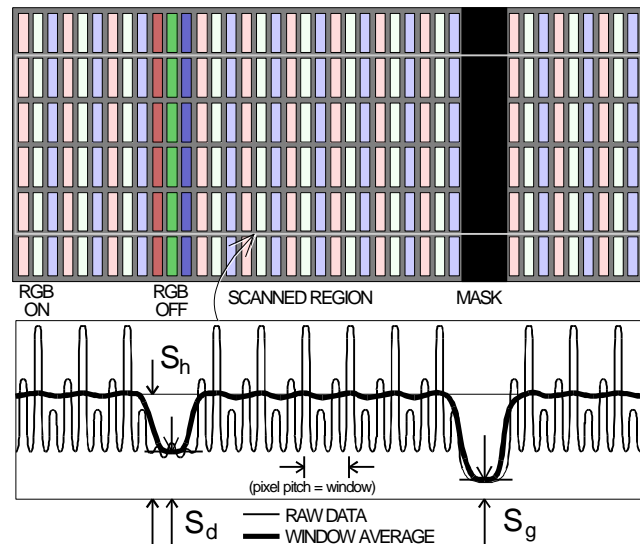
The methods for correcting for veiling glare discussed here are only approximations to attempt to account for the effects of glare. It certainly provides a better measurement than would be obtained without any correction at all. In the previous section we handled the general case. Here we will assume we are trying to measure the luminance of single pixel line. In Fig. 7 we simulate a high magnification image of a black line on a white background where the individual pixels are resolved. In this hypothetical situation, let's assume that we can put a line replica mask directly on the pixel surface. A black opaque mask of width equal to the pixel pitch is placed over a column of pixels no closer than three columns away. An integral number of rows of pixels are scanned either by a scanning device or an array LMD to produce a luminance profile. Then the luminance profile undergoes a window average (moving-window average filter, see A218) where the averaging window is the same width as the pixel pitch in the luminance profile. The resulting averaged profile has an average value associated with the white pixels  $S_h$ , an average valley level associated with the black line  $S_d$ , and the level of the veiling glare  $S_g$  associated with the black-opaque mask. The corrected white is  $S_w = S_h - S_g$ , and the corrected black is  $S_b = S_d - S_g$ . Then, for example, the contrast ratio can be better estimated by  $C = S_w/S_b$ . One problem with this method is that we cannot always get the mask close enough to the pixel surface so that the mask and the pixels are both in focus in our array LMD. This happens when there is a thick covering over the pixel surface. The other problem is that the surface of the display may be delicate so that we cannot touch it with anything, even our little mask—we handle that in the next section.

If possible it is useful to check your results by providing a filter material the same size as the opaque mask and use the method outlined in the previous section to measure the transmission. However, this will usually be difficult or impossible to do because of the small size of the pixel, which can be smaller than the thickness of the filter material used. You can attempt to get some idea by cutting a sliver of filter material with a very narrow angle using a scissors. At some place along the sliver the thickness might be the same as the pixel pitch. Try to arrange for sufficient magnification that 20 *detector* pixels or more are used across the width of the line.



### C. Delicate Untouchable Screens

We want to attempt to simulate the situation in Fig. 7 as best we can. We measure the black corruption in the line replica mask and apply that correction to the black area on the DUT. One way to approximately do this is to create an illuminated surface, a simulated screen, that is the roughly the same size as the screen we are trying to measure. This simulated screen can be made in several ways. It can be a rugged laptop display approximately the same size as the DUT, it may be a piece of glass placed in front of but not touching the screen, a CRT, a backlight by itself, a large box with an illuminated white interior and a rectangle cut in its side the size of the DUT surface, and so forth. The surface should be relatively uniform to the eye. Exactly how big the simulated screen has to be depends upon the apparatus used. Certainly, if the simulated screen is the same size (within  $\pm 10\%$  or so) as the screen to be measured, there will likely be no size problem. On the other hand, if the apparatus is essentially not affected by light beyond  $20^\circ$  from its optical axis, then the simulated screen need only subtend a cone with a  $40^\circ$  apex angle. Once the simulated screen is made, place a line replica mask on that surface that has the width of the pixel pitch. In practice, the replica mask should be  $-0\%$  to  $+10\%$  of the pixel pitch. The line replica mask may be made from black hair, horse hair (if the hair is not black, use a black marker to darken it sufficiently), fine striping tape, black nylon sewing thread, strand of wire or thin pencil lead blackened with a black marker, or a mask carefully cut from black gloss plastic or other black material. Sometimes a very narrow triangularly shaped sliver of material can be cut from plastic using scissors and will work as an approximation to the line if you measure where its thickness is approximately the pixel pitch. A glossy black surface is preferred, if possible, to reduce the effects of diffuse reflections from the environment although specular reflections can be a also be a problem. An acceptable mask material will have to be determined for each apparatus and configuration. Clearly, a line replica mask will be easier to create to simulate a line than a character-shaped replica mask to simulate a character. The scanning or array LMD then measures the across the ideal black line on the white surface obtaining a white level  $S_s$  of the simulated screen and a black level  $S_g$  that is essentially the veiling glare corruption. Then the DUT can be measured similarly obtaining a white level  $S_h$  that is the average of the white area and a measurement of the black area  $S_d$ . The equivalent correction for the veiling glare adjusted for the actual screen luminance is  $S_h S_g / S_s$ . The corrected white is  $S_w = S_h (1 - S_g / S_s)$ , and the corrected black is  $S_b = S_d - S_h S_g / S_s$ . Again, this is an approximation for the veiling glare corruption. One of the problems with this method is that the amount of veiling glare is not constant across the mask. As we get closer to the white-black boundary, we will find that the glare increases. It will be a minimum at the center of the black area. However, when you try this method out, you may well find that the amount of veiling glare corruption is substantial (much more than most think). The correction you make will be vastly superior than using measurements that don't attempt to account for glare. For example, suppose we measure the uncorrected black and white levels to be (in CCD counts from a photopic CCD camera)  $S_h = 12000$  and  $S_d = 2500$ . We'd naively calculate the contrast to be  $C = S_h / S_d = 4.8$ . If we attempt to account for glare and find that  $S_g = 1500$  and  $S_s = 16000$  using the simulated display. Then the correction is  $S_h S_g / S_s = 1125$ , and a better approximation to the contrast is  $C' = S_w / S_b = 10875 / 1375 = 7.9$ , which is quite different from  $C$ . Whether or not the eye can appreciate that change in contrast is really not the point of all this. What we need to do is to provide as accurate a measurement as possible so that any ergonomic study of the significance of small area contrasts is based on good metrology.



**Fig. 7.** Hypothetical high-magnification image of black pixel line on white pixel background with an ideal black-opaque mask placed directly upon the pixel surface. This is an ideal situation to illustrate what we are attempting to do. Do not attempt to touch the screen surface unless you are sure it is rugged enough to permit such rough handling.

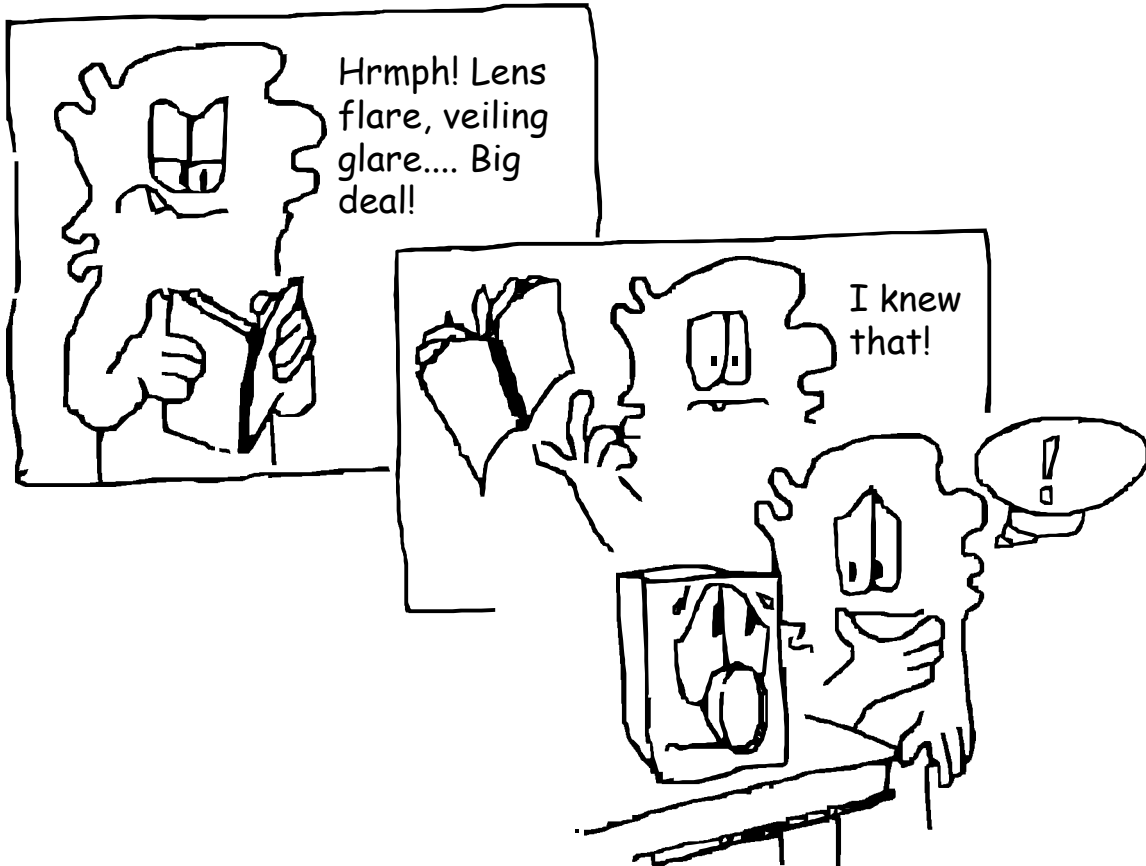


### D. Rugged Screens That Can Be Touched



**DANGER! BE SURE THAT YOUR SCREEN SURFACE IS DESIGNED TO BE TREATED ROUGHLY BEFORE ATTEMPTING TO ATTACH ANYTHING TO THE SCREEN SURFACE.**

Obviously, the above method for delicate surfaces will also work for rugged screens. However, the rugged screen offers more possibilities. Temporarily attach a one-pixel-pitch-wide strip mask to the surface of the screen (if the screen will allow it, tape might be used), and align it with a column of pixels as shown in Fig. 5. View the mask and black pixel line in the LMD. If the mask and the pixel surface are both in focus (the lens system has a sufficiently large enough depth of field to include the pixel surface and the mask on the cover above the pixel surface) proceed as if it were the ideal case in a) above. However, if both the pixel surface and the mask is not in focus, then data will have to be obtained with the pixel surface in focus and then with the mask in focus separately. When the pixel surface is in focus, we obtain the average white level  $S_h$  surrounding the line and the black level  $S_d$  of the line, both uncorrected values. When the mask is in focus we obtain the veiling glare corruption  $S_g$  and the average white level (again made with a running window average where applicable)  $S_s$  where the background pixels are now out of focus. The correction is now  $S_h S_g / S_s$ , the corrected white is  $S_w = S_h(1 - S_g / S_s)$ , the corrected black is  $S_b = S_d - S_h S_g / S_s$ . Then, for example, the contrast will be approximated with  $C = S_w / S_b$ .





## A102 SPATIAL INVARIANCE AND INTEGRATION TIMES

(measurement area and interval, adequate number of pixels measured, adequate duration of measurement, temporal aliasing, spatial aliasing)

**Abstract:** Too short an integration time can alias with the screen refresh rate (if such exists). Also measuring too few pixels can result in a false representation of the true luminance of the display as well as changes in the luminance if the luminance meter moves slightly. Similar problems can arise with the measurement of colors.

There are two types of apertures associated with a luminance measurement, one is the aperture defined by the measurement area or field of view (FOV) on the screen, the other is the "aperture" in time over which the measurement is made usually called the measurement time interval. Because the screen is composed of discrete pixels, moving the measurement aperture around on the screen can change the number of pixels contained in the aperture by a small amount especially if the FOV is very small. If one were to move the LMD in one direction along the screen making measurements frequently, a beat-frequency pattern could emerge in the luminance-verses-position curve measured, i.e., an aliasing would occur owing to the well-defined measurement aperture and the discrete pixels. Similarly, because the screen can have a refresh rate associated with it whereby the pixels are turned off for a period of time, the finite measurement time interval can have an error in the number of screen refreshes it measures if it is not synchronized with the refresh period.

### A102-1 Minimum Measured Region of Display Surface: (number of pixels measured)

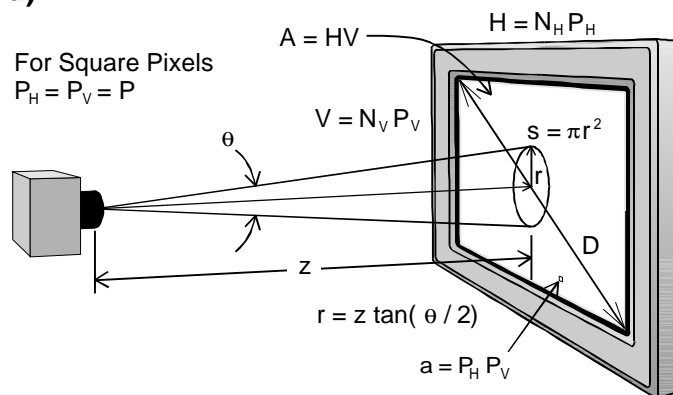
How many pixels need to be measured for an accurate luminance measurement? That depends to some extent upon the pixel fill factor as well as the type of LMD used (how locally uniform the pixels are found to be). As the fill factor decreases below 100 %, the light measurement can change more as the LMD moves unless the LMD is covering a sufficient number of pixels, or some other factor mitigates the irregularities. In some cases pixel-to-pixel irregularities in luminance (or color) can be large. (See section 301-2h, Viewing Distance, Angle, and Aperture, where this specification is introduced.) For simple LMD systems we suggest the following guidelines be used:

- 500 pixels or more be measured.
- The field of view of the LMD on the display surface ( $2r$  in the figure) be less than 10 % of the horizontal and less than 10 % of the vertical dimension of the screen for the perpendicular orientation; that is, the measuring region (FOV,  $s = \pi r^2$ ) will fit within a box on the screen having dimensions of  $0.1 V \times 0.1 H$ .
- The LMD have an angular field of view (for infinity focus) of  $2^\circ$  or less.
- The lens of the LMD subtends  $2^\circ$  or less from the center of the screen.

If fewer than 500 pixels need to be measured, it is necessary to prove that such a measurement will not significantly contribute to the measurement error. Similarly, if any other of these conditions are not met, it must be proven that the measurement apparatus is able to provide a measurement that is equivalent to meeting these specifications. See the diagnostic below for a method to verify the adequacy of the number of pixels selected to be measured. There is no need to perform this diagnostic if more than 500 pixels are measured.

#### A. Diagnostic—Suitability of Chosen Number of Measured Pixels:

Suppose you need to use fewer than 500 pixels and you want to test to see if it is reasonable to do this. Arrange for the LMD to measure the number of pixels you desire near the center of a full white screen. Stay within  $0.1 V \times 0.1 H$  of the center of the screen. Find a visibly uniform field of pixels to measure in order to avoid





anomalous pixels that will introduce errors. Be sure to rigidly mount both the LMD and the DUT so that they are securely in place and will not accidentally or inadvertently be moved. Note that this kind of verification or diagnostic need only be made on one type or class of a display-LMD combination when a series of displays are measured. It does not need to be performed on all displays. In other words, it is sufficient to measure less than 500 pixels if it is possible to prove that a class of apparatus can adequately meet these criteria for a certain class of displays.

1. Take a series of measurements on the properly warmed-up DUT, and establish the **repeatability of the measurement** of the luminance (or color) with the DUT and the LMD held fixed. Determine the average value  $m$  and its standard deviation  $s$  using at least  $n = 10$  measurements. (See 301-2k for more information and a procedure if needed.) It would be expected that  $s$  would be smaller than the measurement repeatability requirement of this document ( $s_{\text{LMD}} = 0.5\%$ ), and would certainly expect that it would be less than twice the measurement repeatability requirement, that is,  $s \leq 2s_{\text{LMD}} = 1\%$ —this assumes your LMD has a smaller repeatability than the requirement of this document. If this is not the case and a repeated measurement of ten values doesn't improve the situation, then it may be indicative of a problem with the LMD, the display (perhaps not warmed up or unstable), or the combination of the two (see the next section A102-2 for temporal modulation of the luminance).
2. Make multiple measurements of the luminance (or color) as you transversely move the LMD relative to the screen a distance of  $y = 5$  px vertically and then  $x = 5$  px horizontally (or visa versa) making measurements at the spacing of five increments per pixel,  $\Delta x = P_H/5$ ,  $\Delta y = P_V/5$ , for a total of 50 measurements. (It is easiest to do this with the LMD or display on a positioning system.)
3. Determine the mean  $m'$  and standard deviation  $s'$  of the 50 measurements. Also calculate the maximum deviation  $\Delta_{\text{max}}$  between the lowest and highest measured value of the 50 measurements.
4. Criterion of acceptability: If the standard deviation of the 50 measurements is twice the LMD repeatability requirement or less ( $s \leq 2s_{\text{LMD}} = 1\%$ ) and if the maximum deviation is less than six times the LMD repeatability requirement ( $\Delta_{\text{max}} \leq 6s_{\text{LMD}} = 3\%$ ), then it is permissible to use the number of pixels selected to make the measurements.

## B. Calculation Examples: Number of Pixels Measured and Proper Distance

In the following examples we provide a variety of equations that will permit the calculation of the number of pixels measured assuming a round measurement aperture. We also show some sample calculations. Finally, there is a table showing some common display configurations and the number of pixels measured for a  $2^\circ$  or  $1^\circ$  angular field of view at a distance of  $z = 500$  mm from the display.

**Example 1.** Given an LMD with an angular field of view (AFOV) subtending  $q = 1^\circ$  (radian measure of  $2\pi q/360^\circ$ ) at a distance of  $z = 500$  mm from the screen which has a pixel pitch in both horizontal and vertical directions of  $P_H = P_V = 0.333$  mm so that the area allocated to each pixel is  $a = P_H P_V = 0.111$  (mm)<sup>2</sup>, then the radius of the circle being measured on the screen is  $r = z \tan(q/2) = 4.36$  mm, the area measured on the screen (field of view, FOV) is  $s = \pi r^2 = 59.8$  (mm)<sup>2</sup>, and the number of pixels measured within the LMD aperture on the average is  $N = s/a = 549$  px. Putting this all together, the number of pixels measured is given by



FOR SQUARE PIXELS

$$N = \frac{s}{a} = N_T \frac{s}{A} = \frac{\pi r^2}{HV} N_T = \frac{\pi r^2}{P^2}, \text{ or}$$

$$N = \pi \left[ \frac{z \tan(q/2)}{D} \right]^2 (N_H^2 + N_V^2), \text{ or}$$

$$N \cong \frac{\pi}{4} d^2 \frac{(N_H^2 + N_V^2)}{D^2},$$

(where in the last equation it is assumed that  $z \gg r$ )

- $A$  = area of the screen (viewable area, of course)
- $N_{H,V}$  = number of pixels, horizontal, vertical
- $P_H, P_V$  = pixel pitch in the horizontal/vertical direction
- $P$  = pixel pitch for square pixels
- $H$  = horizontal size of screen =  $N_H P_H = N_H P$  (for square pixels)
- $V$  = vertical size of screen =  $N_V P_V = N_V P$  (for square pixels)
- $r$  = radius of round measurement area on screen
- $s$  = area of screen being measured =  $\pi r^2$  (Goal:  $s < A/100$ )
- $d = 2r$  = diameter of round measurement area on screen  
(should be less than 10% of  $H$  and  $V$ )
- $a$  = area allocated to one pixel =  $P_H P_V$  (=  $P^2$  for square pixels)
- $N_T$  = total number of pixels on the screen =  $N_H N_V$
- $N$  = number of pixels being measured on the screen (Goal: 500 px)
- $z$  = distance from the screen to the LMD
- $D = \text{diagonal} = \sqrt{H^2 + V^2} = P \sqrt{N_H^2 + N_V^2}$   
Note that  $D$  is the exact diagonal of the viewable display surface.
- $q$  = LMD angular field of view ( $^\circ$  or rad:  $^\circ = \text{rad} \cdot 360^\circ/2\pi$ )  
(NOTE: for small angles  $< 10^\circ$ ,  $\sin q \cong \tan q \cong q$  within 1%,  
where  $q \cong d/z$  must be in radians)

**Example 2.** Following Ex. 1, if the round angular field of view measures  $2^\circ$ , the area measured at a distance of 500 mm is  $239 \text{ (mm)}^2$  (radius of 8.73 mm), and with a pitch of 0.333 mm; then the number of pixels would be 2000. With the  $2^\circ$  aperture at a distance of 500 mm the maximum square pixel pitch which will yield 500 pixels being measured is  $P = 0.692 \text{ mm}$  ( $P^2 = s/N$ ).

**Example 3.** Suppose we know the pixel pitch for horizontal  $P_H = 0.723 \text{ mm}$  and vertical  $P_V = 0.692 \text{ mm}$ , and the field of view of the LMD  $q = 1^\circ$ . How far away  $z$  would the LMD need to be in order to capture  $N = 500 \text{ px}$ ? Using the formula in Ex. 1, we solve for  $z$ :

$$z = \sqrt{\frac{NP_H P_V}{\pi \tan^2(q/2)}}, \quad \text{where } \begin{cases} N = \text{number of pixels measured on screen} \\ z = \text{distance from screen to LMD} \\ P_{H,V} = \text{pixel pitch, horizontal, vertical} \\ q = \text{LMD angular field of view } (^\circ, \text{ or rad: } ^\circ = \text{rad} \cdot 360^\circ/2\pi) \end{cases}$$

This gives a distance of  $z = 1445 \text{ mm}$ .

**Example 4.** If we only have the diagonal measure  $D = 14.2 \text{ in}$  (361 mm), the number of pixels in the horizontal  $N_H = 640$  and vertical direction  $N_V = 480$ , and we know that the pixels are square; then we can determine the number of pixels measured by a LMD with angular field of view of  $q = 1^\circ$  and distance from the screen of  $z = 500 \text{ mm}$ :



FOR SQUARE PIXELS

$$N = \frac{s}{a} = N_T \frac{s}{A} = \frac{\pi r^2}{HV} N_T = \frac{\pi r^2}{P^2}, \text{ or}$$

$$N = \pi \left[ \frac{z \tan(q/2)}{D} \right]^2 (N_H^2 + N_V^2)$$

- $N$  = number of pixels measured on screen
- $s$  = area of screen measured =  $\pi r^2$
- $a$  = area allocated to one pixel =  $P_H P_V = P^2$  (for square pixels)
- $N_T$  = total number of pixels on screen =  $N_H N_V$
- $A$  = number of pixels measured on screen
- $H$  = horizontal size =  $N_H P_H = N_H P$  (for square pixels)
- $V$  = vertical size =  $N_V P_V = N_V P$  (for square pixels)
- $z$  = distance from screen to LMD
- $N_{H,V}$  = number of pixels, horizontal, vertical
- $D$  = diagonal =  $\sqrt{H^2 + V^2} = P \sqrt{N_H^2 + N_V^2}$
- $q$  = LMD angular field of view ( $^\circ$  or rad:  $^\circ = \text{rad} \cdot 360^\circ/2\pi$ )

For the values here,  $N = 294$ , which is an insufficient number according to our suggestion of 500 pixels (the LMD-display combination would have to be verified for adequacy)—see 301-2h, Viewing Distance, Angle, and Angular Field of View for initial comments about the 500-pixel suggestion. If the pixels are not square, we would need to know the exact aspect ratio  $a = H/V = N_H P_H / N_V P_V$  in order to calculate the pixel pitch and determine the area of a pixel. In such an unlikely event, the general formula is

$$N = \pi \left[ \frac{z \tan(q/2)}{D} \right]^2 (1 + a^2)/a, \text{ where}$$

- $a$  = aspect ratio
- $N$  = number of pixels measured on screen
- $z$  = distance from screen to LMD
- $N_{H,V}$  = number of pixels, horizontal, vertical
- $D$  = diagonal (of entire screen matrix)
- $q$  = LMD angular field of view ( $^\circ$  or rad:  $^\circ = \text{rad} \cdot 360^\circ/2\pi$ ),

which reduces to the above formula when the pixels are square ( $a = N_H/N_V$ ).

ERGONOMICS IN SOME HANDS  
CAN BE A DANGEROUS THING!



RUSTIC METROLOGY



METROLOGY

**Table 1.** Number of Pixels Measured and Percent of Screen Diagonal Measured for Several Configurations  
 Dec.=decimal, No.=number of,  $z$  = distance between DUT and LMD,  $q$  = AFOV,  $a$  = aspect ratio,  $D$  = diagonal  
 The shaded area denotes failure to comply with 500-pixel and  $\leq 10$  %-of-diagonal convention.

Display Pixels		Diagonal		$z$ (mm)	$q$ (°)	Aspect Ratio $a$		Size of Screen				Measurement Region			No. pixels
$N_H$	$N_V$	(in)	(mm)			Dec.	Ratio	$H$ (in)	$V$ (in)	$H$ (mm)	$V$ (mm)	$d = 2r$ (mm)	in % of $D$	% Area	$N$
640	480	10.4	264	500	2	1.333	4:3	8.32	6.24	211	158	17.46	<b>6.6%</b>	0.71%	<b>2195</b>
640	480	21.0	533	500	2	1.333	4:3	16.80	12.60	427	320	17.46	<b>3.3%</b>	0.18%	<b>538</b>
640	480	21.0	533	500	1	1.333	4:3	16.80	12.60	427	320	8.73	<b>1.6%</b>	0.04%	<b>135</b>
640	480	21.0	533	500	2	1.333	4:3	16.80	12.60	427	320	17.46	<b>3.3%</b>	0.18%	<b>538</b>
640	480	5.2	132	500	2	1.333	4:3	4.16	3.12	106	79	17.46	<b>13.2%</b>	2.86%	<b>8779</b>
640	480	5.2	132	500	1	1.333	4:3	4.16	3.12	106	79	8.73	<b>6.6%</b>	0.71%	<b>2194</b>
640	480	32.0	813	500	2	1.333	4:3	25.60	19.20	650	488	17.46	<b>2.1%</b>	0.08%	<b>232</b>
800	600	11.3	287	500	2	1.333	4:3	9.04	6.78	230	172	17.46	<b>6.1%</b>	0.61%	<b>2905</b>
800	600	15.0	381	500	2	1.333	4:3	12.00	9.00	305	229	17.46	<b>4.6%</b>	0.34%	<b>1648</b>
800	600	22.6	574	500	2	1.333	4:3	18.08	13.56	459	344	17.46	<b>3.0%</b>	0.15%	<b>726</b>
1024	768	12.1	307	500	2	1.333	4:3	9.68	7.26	246	184	17.46	<b>5.7%</b>	0.53%	<b>4151</b>
1024	768	15.0	381	500	2	1.333	4:3	12.00	9.00	305	229	17.46	<b>4.6%</b>	0.34%	<b>2701</b>
1024	768	6.4	163	500	2	1.333	4:3	5.12	3.84	130	98	17.46	<b>10.7%</b>	1.89%	<b>14836</b>
1024	768	6.4	163	500	1	1.333	4:3	5.12	3.84	130	98	8.73	<b>5.4%</b>	0.47%	<b>3709</b>
1024	768	21.0	533	500	2	1.333	4:3	16.80	12.60	427	320	17.46	<b>3.3%</b>	0.18%	<b>1378</b>
1280	1024	13.0	330	500	2	1.250	5:4	10.15	8.12	258	206	17.46	<b>5.3%</b>	0.45%	<b>5897</b>
1280	1024	25.0	635	500	2	1.250	5:4	19.52	15.62	496	397	17.46	<b>2.7%</b>	0.12%	<b>1595</b>
1280	1024	17.0	432	500	2	1.250	5:4	13.27	10.62	337	270	17.46	<b>4.0%</b>	0.26%	<b>3449</b>
1280	1024	42.0	1067	500	2	1.250	5:4	32.80	26.24	833	666	17.46	<b>1.6%</b>	0.04%	<b>565</b>
1280	1024	23.0	584	500	1	1.250	5:4	17.96	14.37	456	365	8.73	<b>1.5%</b>	0.04%	<b>471</b>
1280	1024	23.0	584	500	2	1.250	5:4	17.96	14.37	456	365	17.46	<b>3.0%</b>	0.14%	<b>1884</b>
1280	1024	60.0	1524	500	2	1.250	5:4	46.85	37.48	1190	952	17.46	<b>1.1%</b>	0.02%	<b>277</b>
1920	1080	17.0	432	500	2	1.778	16:9	14.82	8.33	376	212	17.46	<b>4.0%</b>	0.30%	<b>6228</b>
1920	1080	42.0	1067	500	2	1.778	16:9	36.61	20.59	930	523	17.46	<b>1.6%</b>	0.05%	<b>1020</b>
1920	1080	12.0	305	500	2	1.778	16:9	10.46	5.88	266	149	17.46	<b>5.7%</b>	0.60%	<b>12500</b>
3072	2240	13.5	343	500	2	1.371	11:8	10.91	7.95	277	202	17.46	<b>5.1%</b>	0.43%	<b>29418</b>



## A102-2 Measurement Time Interval: (integration time required)

The integration time of the LMD must not be so short that the refresh rate of the screen will affect the luminance measurement more than is allowed by the required measurement uncertainty and precision of the LMD. Some LMDs can be synchronized with the refresh rate of the screen (if applicable), but even so, the measurement time interval can play a role in the uncertainty of the measurement.

### A. Temporal Modulation of Luminance:

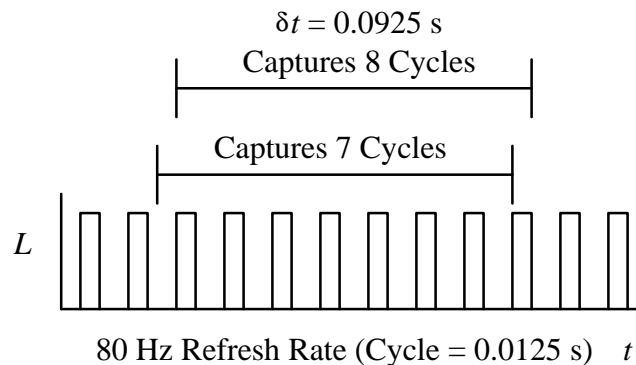
Some LMDs integrate the light over a time interval (or several time intervals) and report the measurement to the user. Some displays have a refresh rate associated with them where the luminance is pulsating in time but fast enough so that it is not objectionable to the eye (otherwise flicker is noted) or there may be a modulation of the luminance from an ac-powered backlight. When the integration time is short compared to a number of cycles of its modulation ( $< 200$  or so) the measured luminance can change significantly depending upon when the measurement time interval occurs and how many pulses or cycles are measured. For example, in the figure we show a refresh rate of  $R = 80$  Hz with the measurement time interval as  $\delta t = 0.0925$  s, then on the average there will be 7.4 refresh cycles captured by the instrument [No. cycles =  $R \delta t = \delta t/(1/R)$ ]. But for any single measurement the number of refresh cycles captured can be from 7 to 8 which would give a range of luminance errors from  $-5.4\%$  to  $+8.1\%$ .

### B. Diagnostic—Verification of Adequate Integration Time

The adequacy of the integration time interval can be checked after the display is warmed up. The measurement time interval for a white screen must be long enough so that the standard deviation  $s$  of ten or more luminance measurements (taken quickly) is no greater than twice the measurement repeatability  $s_{\text{LMD}}$  allowed for the luminance meter in this document or  $1\%$  ( $s \leq 1\%$ ,  $s_{\text{LMD}} = 0.5\%$ ); see 301-2j Assessment of Luminance Measurement if more details are needed on how to do this properly. If the standard deviation is too large, one explanation for this is that the integration time is too short. The problem can be solved either by using a neutral density filter, by taking the average of a number of measurements, or by synchronizing the LMD with the light pulses from the display (an available feature with some LMDs).

**Extension of Integration Time:** The measurement time interval can be extended using a calibrated neutral density filter (NDF), and the standard deviation of the luminance measurement re-measured. Given that the density of the filter is  $D$ , then the transmission  $T$  of the filter is  $1/10^D$  and the integration time is extended by a factor of  $1/T = 10^D$ ; for typical densities:  $D = 0.3$ ,  $1/T = 2.00$ ;  $D = 0.5$ ,  $1/T = 3.16$ ;  $D = 1.0$ ,  $1/T = 10$ , etc. If after the extension of the integration time the standard deviation does not appropriately decrease, then other instability problems may exist in the LMD, the display, or both. Be careful in using NDFs. Some have transmissions that are wavelength dependent and may not be suitable for use with photopic or color measurements. The NDFs made from metallic deposition on glass tend to be much less wavelength dependent while the gray-glass type can exhibit a wavelength dependence that can corrupt a luminance measurement beyond what is tolerable in this document.

**Averaging Several Measurements:** How many measurements are required to be comfortable that the mean of a series of  $n$  measurements reflect the true value of the measurand, e.g., luminance? Assuming that the distribution of the measurements about the true value of the measurand is represented by a normal (or Gaussian) distribution, the standard deviation of the mean is given by  $s_N = s/\sqrt{n}$ . Make enough measurements  $n$  so that  $s_N$  is no greater than twice the repeatability of the LMD as above ( $s_N \leq 1\%$ , with  $s_{\text{LMD}} = 0.5\%$ ).



**Fig. 1.** Temporal aliasing of luminance measurement time interval with screen refresh rate.



## A103 LIGHT MEASUREMENT DEVICES

### A103-1 General Uncertainty Requirements of the LMD

There are many factors that contribute to the confidence that the measurements we make actually reflect the value of the measurand. A complete description of all the factors that can affect measurement uncertainties is found in CIE Publication No. 69, “Methods of Characterizing Illuminance Meters and Luminance Meters.” For a discussion of the propagation of errors and uncertainty estimation see A108 Uncertainty Evaluations, and for the correct terminology see A221 Statements of Uncertainty. Any uncertainty values are expressed using an expanded uncertainty with a coverage factor of  $k = 2$  (a “two-standard-deviation” or “two-sigma” estimate)—see A221.

**For Luminances:** The luminance relative expanded uncertainty of measurement with coverage factor of two must be  $u_{\text{LMD}} = \pm 5\%$  of the luminance or less, and the luminance measurement repeatability must be less than either a maximum of  $s_{\text{LMD}} = \pm 0.5\%$  of the luminance or the uncertainty introduced by any digitization (whichever is larger) over a 5-min interval.

**For Color:** The expanded uncertainty of the measurement with coverage factor of two of chromaticity coordinates for tungsten-type CIE illuminant A above  $10 \text{ cd/m}^2$  must be  $\pm 0.002$  or less.

**Array Photodetectors:** In addition to the above requirements, in the event that an array of photodetectors is used in order to provide a spatially-resolved luminance measurement, then such a system must provide (either in hardware or after software processing) no more than a  $\pm 2\%$  nonuniformity (1 – minimum/maximum) for all detection elements employed in a measurement of luminance. If such LMDs are used to resolve fine detail at the pixel level then the array pixel must measure no more than 1/10 the size of the smaller of the horizontal and vertical subpixel-image pitch on the display. That is, the smallest feature of interest should be rendered by at least ten detector pixels in the horizontal or vertical direction. The array must be filtered to make it photopic (whenever luminance measurements are made). We invoke the CIE criterion of specifying the relative spectral responsivity from the human photopic response curve  $V(\lambda)$  so that  $f_1' \leq 5\%$ . (See CIE Publication No. 69, “Methods of Characterizing Illuminance Meters and Luminance Meters,” p. 9, 1987.) Let  $s(\lambda)$  be the response of the photopic array to the spectrum  $S(\lambda)$  (such as illuminant A, a tungsten halogen lamp at 2856 K), the error  $f_1'$  is defined as

$$f_1' = 100\% \frac{\int_0^\infty |s^*(\lambda)_{\text{rel}} - V(\lambda)| d\lambda}{\int_0^\infty V(\lambda) d\lambda}, \quad \text{where} \quad s^*(\lambda)_{\text{rel}} = s(\lambda) \frac{\int_0^\infty S(\lambda) V(\lambda) d\lambda}{\int_0^\infty S(\lambda) s(\lambda) d\lambda}.$$

See Section A111 Array Detector Measurements for a discussion of the complications that can arise when array detectors are used.

### A103-2 Field of View and Subtense Angle of LMD

The angle of the field of view (FOV), field angle, acceptance angle, or angular FOV (AFOV) of the measurement aperture must be  $2^\circ$  or less for infinity focus. Further, the angle subtended by the lens of the LMD from the center of the screen must also be  $2^\circ$  or less for image-producing systems. There may be optical configurations that do not produce images on the photodetector of the LMD. This criterion is then equivalent to stating that all the rays coming from any pixel which contributes to the measurement made by the LMD must fall within a cone with apex angle of  $2^\circ$  or less. Further, all the rays coming from the centers of the measured pixels must be within  $2^\circ$  of the viewing direction. If the LMD used has an angular field of view larger than  $2^\circ$  then its suitability must be tested with the DUT; see Light Measurement Devices (A103) in the Metrology Appendix for diagnostics.

Some say FOV or aperture meaning the AFOV. Strictly speaking, these are not adequate terms. The FOV can mean the horizontal (or maximum) size of an area viewed, or the width of the viewed area at a certain distance. Aperture has been used to refer to the measurement aperture within the instrumentation, the FOV on the measured item, or the entrance pupil of the LMD. We will generally use AFOV.

#### A. Diagnostic: Subtense Angle Suitability of LMD

The solid angle subtended by the LMD may be important to good measurements. If the display exhibits a viewing angle dependence then the finite solid angle subtended by the LMD can have an effect on the



measurement. The LMD should be placed a sufficient distance from the display or the LMD must be designed so that the change in luminance or color over the surface of the lens (or aperture) of the LMD for any displayed level from white to black or any color is essentially within the reproducibility of the LMD. Note: some configurations are collimated and can have a wide lens yet only use a small angular cone of light from each pixel (see A219 Collimated Optics). Also some systems use an optical Fourier transform lens near the screen, but may be suitable because of their design (see A226 Equipment Based on Fourier Optics).

This document suggests that the angle subtended by the lens (or entrance pupil) of the LMD (or each of its elements if it is an array detector) should be no greater than  $2^\circ$ . Suppose you want to use a LMD having a lens (or other means of gathering light) that has a subtense angle of greater than  $2^\circ$  as measured from the center of the screen, and you want to see if it is suitable for making measurements of a display. Let the subtense angle of the lens be  $q_L$ . Make a series of ten measurements at the perpendicular direction (or design viewing direction) to establish the mean  $m$  and standard deviation  $s$  of the luminance (or color measurement). We will assume that the standard deviation obtained will be no greater than twice the repeatability requirement of the LMD ( $s_{LMD} = 0.5\%$ ),  $s \leq 2s_{LMD}$  or  $s \leq 1\%$ , which is a rather sloppy measurement. In fact, if we find that the standard deviation is *not* smaller than our repeatability requirement  $s \leq s_{LMD}$  it raises the question that you may have a problem with the LMD, the display, or the combination. You may want to try this for both a full-white screen and a full-black screen. With the pivot point at the center of the screen, rotate the LMD  $\pm q_L/2$  about the perpendicular to the left and then the right of the screen normal making ten measurements in each position. For each off-normal position determine the mean  $m'$  and standard deviation  $s'$ , and check that the off-normal standard deviations are both less than twice the repeatability requirement of the LMD,  $s' \leq 2s_{LMD}$  or  $s' \leq 0.5\%$ .

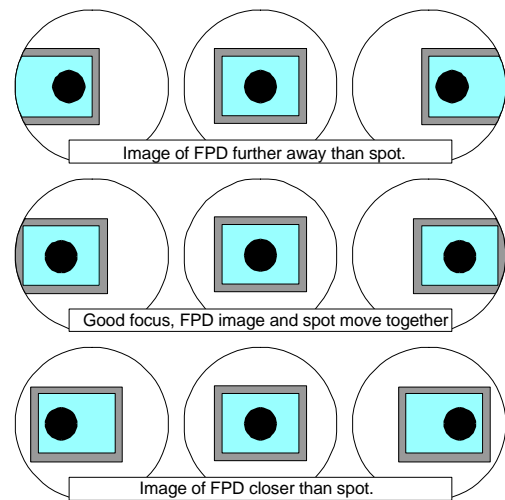
### A103-3 Types of LMDs

In this document we primarily talk about luminance meters, etc. which have a viewing port. There are some measurement apparatus that are designed to be positioned close to the screen or even directly in contact with the screen. We want to include as many measurement options as possible.

#### A. Imaging LMDs

These LMDs show the area being measured on the object by creating an image of the object using a lens and then sampling part of that image to produce the measurement. Many of these LMDs have a viewing port or viewfinder (either optical or video) so the lens focuses the image of the object to be measured onto the detection aperture. It is always important to properly focus the device so that the image lies essentially in the plane of the measurement aperture. When using the eye to focus the instrument, it is easy to be fooled into thinking that it is properly focused when it is not. Here is a procedure to assure proper focus:

**Parallax Method for Viewfinder Focus:** First the viewfinder eyepiece is focused so that the target denoting the measured area (FOV target) is sharp in focus and comfortable to view (many use an infinity focus, some use a focus that is at a reading distance). The key is to be sure that the image of the object being measured is exactly in the plane of the LMDs measurement aperture. As you look at the object to be measured, if its image in the viewfinder moves relative to the FOV target as you make small transverse movements with your eye, then the LMD is not properly focused. When we say small transverse motions of the eye, what you do is move your head back and forth (left and right or up and down) just a few millimeters (some rotate their head slightly so that the eye moves transversely a few millimeters) while looking through the eyepiece having the image and FOV target in view. Focus the main lens of the LMD until small transverse movements of the eye do not show any relative motion or parallax of the image with the FOV target. This has been called the parallax method of focusing a device.





## B. Proximity Optical Fourier Transform Devices:

There are devices that are based on measurements upon the optical Fourier transform (OFT) of the image. OFT LMDs are often in close proximity with the display surface (a few millimeters away). Care must be exercised to avoid touching any delicate display surfaces in using these devices. The OFT LMD provides a measurement of almost the entire  $2\pi$  sr hemisphere in front of the display at one time. Since they employ array photodetectors, the requirements are presented above (Array Photodetectors) and further discussion of array-detector complications can be found in A111. More information about OFT devices, how they work and how to perform diagnostics, can be found in A226 Equipment Based on Fourier Optics.

## C. Large-Solid-Angle Detectors (Suction-Cup or Open-Area Detectors):

If a display technology exhibits viewing angle characteristics (other than nearly Lambertian behavior) unacceptable errors can be introduced by a detector lens covering too large a solid angle so that the screen characteristics are different over that solid angle (like the suction cup colorimeters used on CRT displays). If the FPD technology for the DUT has no viewing angle dependence then these types of detectors may sometimes be used. In general, their use is discouraged for FPDs.

## D. Microscopes, Proximity Detectors:

Other lens configurations exhibit similar problems of having a large solid angle for gathering light. If a microscope or a close-up lens is used, then the apex angle of the cone defined by the light-gathering lens from the viewpoint of the display surface may exceed the  $\pm 2^\circ$  subtense angle of the LMD lens that this document specifies. Their adequacy would therefore have to be tested. For such instruments in close proximity to the screen, there is an additional source of contamination, reflections off the instrumentation back onto the screen. Glare in the lens system should always be anticipated.

## E. Long Distance Microscopes:

Long-distance microscopes generally avoid producing significant reflections of light back onto the screen thereby corrupting a measurement. However, they often have wide lenses in order to provide good resolution and gather more light, and they can exceed the  $\pm 2^\circ$  subtense angle of the LMD lens that this document specifies. Their adequacy would therefore have to be tested. Glare in these lenses, although some of which are mirrored systems, must also be anticipated.

## A103-4 Time-Resolved Measurements

In making time-resolved light measurements such as response times, photopic calibration may not be required. Be cautious about infrared (IR) sensitivity of some non-photopic detectors. The IR emitted from the display may have a very different gray-scale than the visible light would indicate. Sensitivity to IR can produce a dc offset which may or may not be important to an accurate measurement. The response time of the LMD is often required to be 1/10 the duration of the event to be measured or less. However, if the light generated is modulated at a high frequency, it may be necessary to require a response time of the LMD used for temporal measurements to be 1/10 or less of the temporal period of the modulation or change. See the section on Temporal Response Diagnostics (A110) for details on how to check the temporal response capabilities of the LMD used. There are few absolute (repeatable) sources of error in this measurement:

1. Detector non-linearity.
2. Detector time-base error, e.g., the time-per-division on the oscilloscope is wrong.
3. Step-response function (SRF) curve affected by too large a measured target.

Since (1) and (2) above are normally small, and (3) can be controlled by proper target selection, this measurement should be both accurate and repeatable if the following random (non-repeatable) error sources can be controlled:

1. Detector noise.
2. Detector drift.
3. FPD luminance drift.
4. Superimposed luminance ripple (as with a high-frequency backlight).
5. Use of linear interpolation on a non-linear SRF curve.
6. Intrinsic FPD turn-on and turn-off frame-to-frame variations.



### A103-5 Detector Saturation

When measuring displays that produce their light by a train of pulses, such as electron-beam scanned phosphors of a CRT, it is important that the peak of the light pulses not saturate the detector within the LMD. Detector saturation can be determined using the diagnostic for linearity in A106 Detector Linearity Diagnostics. If the ratio of light measured with and without a neutral-density filter stays the same independent of the luminance setting of the display screen (whites or grays), then saturation is not a factor. If there is fear of changing the pulse characteristics by changing the gray-level, then the apparent screen luminance can be adjusted using a second neutral-density filter between the LMD and the white screen. By changing the density of the second neutral-density filter you can simulate a change in gray scale without modifying the pulse shape.

### A103-6 Appearance to the Eye vs. the LMD

The eye has an entrance pupil of less than 10 mm diameter (typically 2 mm to 4 mm). Most LMDs have lenses that have considerably larger diameters. It is worth keeping in mind that what the eye sees and what a LMD sees may be somewhat different. From any point on the display surface, the eye and the LMD often subtend very different solid angles, particularly as the LMD gets closer to the display. Sometimes the detail seen by the eye can be integrated out by the LMD. Sometime, this can be particularly noticeable as when comparing a CCD picture with what the eye sees when examining a non-smooth surface. The LMD-CCD can make the surface appear smoother than it is and any sharp detail behind the surface (such as pixels behind a diffusing screen) may be softened from what the eye sees. There's not much to do about this except to be aware that sometimes stopping down the lens may make the LMD see more like the eye sees things at a cost of sensitivity.

## A104 SIGNALS, COLORS, AND PATTERN GENERATION

In order to make this document be applicable to as many display technologies as possible, only some general remarks will be made concerning signal generation. The pixel responds to a driving stimulus. That driving stimulus has voltage and timing characteristics that can be critical to the display's performance. Depending upon the display technology, that driving stimulus can originate as an analog voltage such as that provided to an RGB CRT monitor, or it can be a bit-level specified at a pixel location for a digital monitor associated with a computer's digital interface. At what point in the generation of the image on the display the user can access and control the driving stimulus cannot be entirely specified for all technologies. For example, gaining access to the signals driving a laptop computer display may be difficult. Even if we could get at those signals there is a risk that the loading of our measurement system's impedance might change the character of the signals and affect the displayed image. Suffice it to say that if a signal generator of some sort drives the display, that signal generator cannot create artifacts that influence any of the measurements specified in this document. To the extent the user has control of the driving stimulus, that driving stimulus cannot be inadequate in any way so that the measurements specified in this document are affected by the performance of the user-provided driving stimulus. For example, consider an analog signal generator: The voltage levels must be sufficiently accurate that they do not adversely influence the luminance levels of the pixels. Further, the transition times between voltage levels must be sufficiently fast so that no luminance artifacts can be measured associated with any two neighboring pixels which are caused by the signal generator. Therefore, when the user of this document is required to provide the driving stimulus for the display, the adequacy of that driving stimulus is the responsibility of the user. Any reporting should include the specifications and characteristics of any external generator if used.



## A105 ADEQUACY OF SINGLE MEASUREMENTS

**Making Single Measurements:** Generally speaking, the measurement repeatability of any LMD will be much smaller than its uncertainty of measurement. At the time of this writing, the best luminance calibration and measurement is usually  $\pm 1\%$  with a coverage factor of  $k=2$ —and that is at the national standards laboratory level. The measurement repeatability of any LMD can be 1/10 of its accuracy of measurement or smaller.

The issue of how many measurements need to be made to establish any measurement result was discussed—in part—in the introductory comments for Section 300 Photometric and Colorimetric Measurements. In this document, we call for making only one measurement for each quantity to be measured. Often people feel the need to make multiple measurements of each quantity where the mean and standard deviations are reported. That, of course, is permissible throughout this document. There are several reasons for our only requiring a single measurement. Photometry and colorimetry are sciences for which the short-term imprecision of the measurement usually is much smaller than the inaccuracies as noted above. This has to do with the determination of the candela from fundamental standards. Once it has been determined that the measurement time interval is not too small so that the luminance measurement is not affected by any refresh rate associated with the display (see A102 Spatial Invariance and Integration Times), there is little value obtained in making multiple measurements—except to check results. As far as comparing the results of one laboratory with another, the  $\pm 2\%$  or  $\pm 4\%$  uncertainty of measurement and methods used are the problem, not the repeatability (shot-to-shot imprecision) of the measuring instrumentation. For the sake of simplicity and speed, we have opted not to require tedious multiple measurements until the fundamental quantities are substantially more accurately determined. In all our measurements, there is no objection to making multiple measurements and reporting the average values. It is always suggested that multiple measurements be made in order to uncover any possible problems, but we don't require them because a number of those using this document will be making many measurements on many displays and will have a keen sense of how well their instrumentation is working. Thus, you can make single measurements, but you have to know the repeatability of the results—see 301-2k to measure the standard deviation, the repeatability, using a coverage factor of two, would be twice the standard deviation. The results have to reproduce within the repeatability of the LMD, then the instability of the DUT is negligible, and you can trust the single measurement. If the variation of multiple readings is much larger than the repeatability of the LMD, then there may be instabilities of the DUT, the LMD, or other unknown uncertainties in the measurement. If the single-measurement criteria (of multiple measurements being within the repeatability of the LMD) is not obtained, then the true repeatability (twice the standard deviation) must enter in the final uncertainty determination of the measurement—see A108 Uncertainty Evaluations.

If there are no substantial aperture or time-interval effects introducing errors in the measurement (see above section A102), then making a number of measurements, taking the average and standard deviation, will reflect little more than the measurement repeatability of the instrument. It is probably a good idea, from time to time, to make a number of measurements of a white screen holding the LMD in a fixed position to assure yourself of a small measurement repeatability and that there are not unanticipated problems. However, there is little value in insisting on making multiple measurements for each luminance value desired, until the uncertainty of measurement of the LMD is comparable to its imprecision. If there is any question how to make mean and standard deviation measurements, see 301-2k Luminance Measurement Repeatability for guidance.



## A106 DETECTOR LINEARITY DIAGNOSTICS

The linearity of any light measuring device (LMD) used in the procedures outlined in this document should be checked to assure accurate measurements. There are several methods that can be used to check the linearity of a LMD.

**Integrating Sphere Variable Source with Photopic Detector:** This is probably the best way to check linearity. Refer to Fig. 1. A small integrating sphere containing a tungsten-halogen lamp is mounted to a larger integrating sphere with a iris between the two spheres. This arrangement produces a uniform diffuse source that does not change its spectrum as the

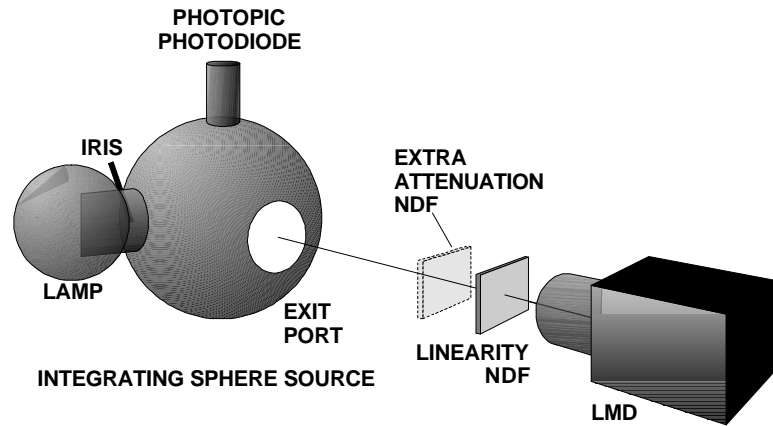
luminance is changed. For this diagnostic we don't need the neutral density filters (NDFs) to start with. If the photopic photodiode monitor is linear (for a simple photodiode bathed with this much light, this is generally a good assumption), then the luminance measured by the LMD  $L$  should track the photodiode output current  $J$  as the iris changes the luminance. If the ratio of the luminance to the photodiode current is not the same for all luminances (within the repeatability of the LMD), then the LMD may not be linear and made need adjustment, the photodiode may be changing its characteristics due to heating, or the photodiode is improperly configured (improperly baffled so that it directly views the lamp exit port). That is, if the LMD is linear (and so is the photodiode) then

$$L = kJ, \quad (1)$$

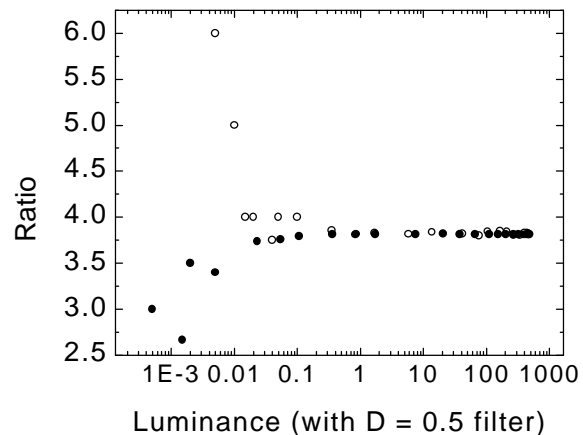
where  $k$  is a constant ( $\text{cd}/\text{m}^2/\text{A}$ ). For all the readings made see how much  $k$  changes over the range of luminance available. If you attempt to use a resistor in series with a photodiode and rely upon  $V = JR$  to produce a voltage proportional to the current, be careful that  $R$  is not too large or the photodiode will not be able to supply enough power to drive the resistor appropriately, and the photodiode detector will appear nonlinear—this method is not recommended. It is much better to use a current amplifier or obtain an ammeter capable of accurate sub-microampere measurements.

If you want to check the low-level response of the LMD, then place an extra attenuation NDF in front of and near the lens of the LMD. If the LMD is linear, it should track the photodiode current so that  $L = k'J$ , where  $k'$  is a different constant. Note that as the luminance nears the lower end of the LMD's capability, rounding errors and digitization errors will eventually dominate. At such levels the LMD cannot be readily used.

When using the NDFs be careful of reflections from items in the lab illuminated by the light source reflecting off the NDF into the LMD. When using a NDF in this manner, it may be tempting to place it near and in front of the integrating sphere. This is not a good idea since anything in proximity to the exit port can dramatically



*Fig. 1. Integrating sphere source with photopic photodiode to monitor luminance and iris to control the luminance without changing its color.*



*Fig. 2. Linearity test method measuring the ratio of the luminance without to the luminance with a neutral density filter having a density of 0.5 against the luminance measured in  $\text{cd}/\text{m}^2$ . Two different luminance meters are compared. The large excursion comes from truncation errors associated with the number of significant figures in the readout.*



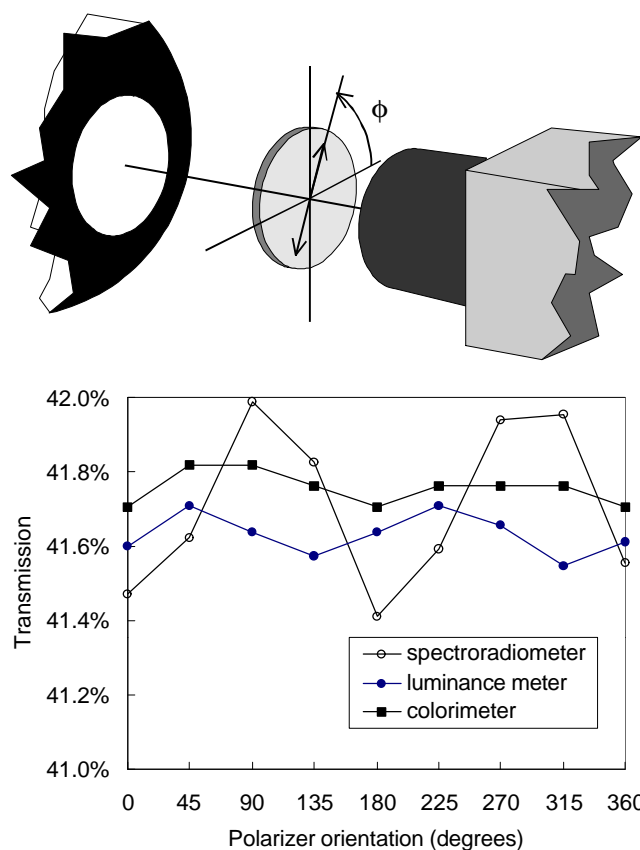
change the luminance of the interior of the integrating sphere. It is best to place the NDFs as near to the LMD lens as is practical. If this is not done, then stray light reflecting off the lens can reflect off the NDF and back into the LMD.

Another way to check the system is by using an NDF taken in and out of the light path. Measure the luminance with  $L'$  and without  $L$  the linearity NDF near and in front of the lens of the LMD. Typically we use an NDF with a density of 0.3 or 0.5. If the LMD is linear, then the ratio of  $L/L'$  should remain constant. This method can be carried to the low end of the LMD range by adding an extra attenuation NDF and checking that the ratio of the luminances with and without the linear LMD remains constant. This method doesn't rely on the photodiode, but the method will not catch slow deviations from linearity. In Fig. 2 we show the results of this NDF method of testing luminance linearity. Caution: many NDFs do not have a uniform attenuation over the entire visible spectrum, particularly this is true for NDFs made of gray glass. NDFs made from metal deposition on glass tend to have a more uniform attenuation over the visible spectrum.

There is another danger: If you attempt to use a light source that changes its luminance by changing the current in the lamp you will probably also be changing the spectral output of the lamp. This situation is undesirable as it introduces an uncontrolled variation into the experiment. A light source that changes its luminance without changing the spectral distribution of the light is preferred.

## A107 POLARIZATION EFFECTS DIAGNOSTICS

There are two main sources of polarized light in emissive displays: the backlight of an LCD display is polarized during transmission, and reflected light off the surface of the display can be polarized. To determine any sensitivities of the LMD to this polarized light, the following procedure is recommended. Simply place a polarizer across a stable uniform light source (such as an integrating sphere source or equivalent) and measure the luminance of the source for different angles of rotation of the polarizer. Fig. 1 shows a typical measurement setup and resultant data. A simple sheet polarizer film or glass polarizing filters can be used and placed in a graduated rotational mount. At minimum, two points should be measured: the position that provides the maximum s-wave transmission (light polarized in the direction perpendicular to the plane of incidence), and the position that provides the maximum p wave transmission (light polarized in the direction parallel to the plane of incidence). If the source is not polarized and the detector is insensitive to polarization, then the ratio of the luminance of the source without the polarizer to the luminance with the polarizer should be constant for any angle of rotation. For a good polarizer, this ratio should be around 40 % to 45 %. Figure 1 shows an example of the plot  $L_f/L_0$  versus  $f$ , where  $f$  is the angle of rotation of the polarizer,  $L_f$  is the measured source luminance with the polarizer rotated by  $f$  degrees, and  $L_0$  is the initial measured source luminance (with no polarizer).



**Fig. 1.** Polarization sensitivity to transmission for a colorimeter, luminance meter, and a spectroradiometer as a function of polarizer orientation.



## A108 UNCERTAINTY EVALUATIONS

We present a summary of error propagation and then apply it to several specific measurements in this document. For more detail, see the many books that cover this subject. For a discussion of the proper terminology to use with statements of errors see A221 Statements of Uncertainty.

In general, every quantity  $Q$  we attempt to measure is a function of other variables or parameters in the experiment so we can write  $Q = Q(p_1, p_2, p_3, \dots, p_n)$ . Each parameter  $p_i$  has an uncertainty  $\Delta p_i$  associated with it. If we want to ask how  $Q$  is affected by small changes in the parameters  $p_i$ , we could set up an experiment where we change each parameter by its estimated uncertainty (in either the positive or negative direction) and re-measure  $Q$  for each change. The change in  $Q$  can be expressed in terms of its partial derivatives:

$$\Delta Q = \sum_{i=1}^n \frac{\partial Q}{\partial p_i} \Delta p_i, \quad (1)$$

where the  $\Delta p_i$  are the changes in the parameters and  $\Delta Q$  is the resultant change in  $Q$ . To take an average of a number  $N$  of the  $\Delta Q$  should result in zero since the changes can be negative or positive, in general. A better measure of the error would be the square-root of the average of the squares of the  $\Delta Q$ . So, for  $k = 1, 2, \dots, N$  such experiments we have as the average uncertainty in  $\Delta Q$  expressed as

$$(\Delta Q)^2 = \frac{1}{N} \sum_{k=1}^N \left( \sum_{i=1}^n \frac{\partial Q}{\partial p_i} \Delta p_i \right)_k^2 = \frac{1}{N} \sum_{k=1}^N \left( \sum_{i=1}^n \left( \frac{\partial Q}{\partial p_i} \Delta p_i \right)^2 \right)_k + \frac{1}{N} \sum_{k=1}^N \left( \sum_{\substack{i=1, j=1 \\ i \neq j}}^n \frac{\partial Q}{\partial p_i} \frac{\partial Q}{\partial p_j} \Delta p_i \Delta p_j \right)_k. \quad (2)$$

Over a large number of such experiments, the second term on the right—the cross-terms—will eventually average to zero since both positive and negative changes in the parameters are allowed. An estimate of the anticipated change in  $Q$  will result when the parameters are all changed by their anticipated uncertainties. Since the changes in the parameters are squared in the first term their respective signs are not important; dropping the cross-terms, Eq. 2 reduces to

$$(\Delta Q)^2 = \sum_{i=1}^n \left( \frac{\partial Q}{\partial p_i} \Delta p_i \right)^2. \quad (3)$$

Another useful expression is the relative uncertainty where we divide Eq. 3 by  $Q^2$  to obtain

$$\left( \frac{\Delta Q}{Q} \right)^2 = \sum_{i=1}^n \left( \frac{1}{Q} \frac{\partial Q}{\partial p_i} \Delta p_i \right)^2. \quad (4)$$

This often results in an algebraic simplification of the uncertainty expression. The uncertainty  $\Delta Q$  or relative uncertainty  $\Delta Q/Q$  is the square-root of the sum on the right side of the equation.

Equation 3 is a statement of the propagation of errors from the parameters that contribute to the resulting measurement. If any one of the parameters  $p$  were dependent upon other variables  $r_j$ , then a similar expression would be used to estimate the anticipated error in  $\Delta p$  in terms of the uncertainties  $\Delta r_j$  and the partial derivatives  $\partial p/\partial r_j$  just as expressed in Eq. 3. Then that  $\Delta p$  value would be used in the expression for  $\Delta Q$ —a compounding of errors, a propagation of errors. There are certain circumstances when Eq. 3 becomes rather simple. Suppose  $Q$

depends upon a multiplication of the powers (positive or negative) of the parameters, such as  $Q = \prod_{i=1}^n p_i^{s_i}$  where the

$s_i$  are positive or negative real numbers, for example  $Q = A^n B^m C^r D^s$ . If we calculate  $\Delta Q$  by Eq. 3 and divide by  $Q^2$  we obtain the relative uncertainty of  $Q$  that has a particularly simple form:

$$\text{for } Q = \prod_{i=1}^n p_i^{s_i} \text{ then } \left( \frac{\Delta Q}{Q} \right)^2 = \sum_{i=1}^n \left( s_i \frac{\Delta p_i}{p_i} \right)^2 \quad (5)$$

$$\text{e.g., for } Q = A^n B^m C^r D^s \text{ then } \left( \frac{\Delta Q}{Q} \right)^2 = \left( n \frac{\Delta A}{A} \right)^2 + \left( m \frac{\Delta B}{B} \right)^2 + \left( r \frac{\Delta C}{C} \right)^2 + \left( s \frac{\Delta D}{D} \right)^2. \quad (6)$$

Here, the  $s_i$  as well as  $n, m, r, s$ , can be any positive or negative real number.



Another case of interest is the situation where  $Q$  is a sum of other quantities:  $Q = p_1 + p_2 + p_3 \dots + p_n$ . Equation 3 is, of course, still valid. When we have such a sum, we often have that the  $p_i$  are similar in size  $p$  and all have approximately the same uncertainty  $\Delta p$  each. Should this be the case, then some simplification occurs:

$$(\Delta Q)^2 = \sum_{i=1}^n (\Delta p_i)^2 \cong n\Delta p^2, \quad \text{and with } Q \cong np \text{ we can estimate } \left(\frac{\Delta Q}{Q}\right)^2 \cong \frac{1}{n} \left(\frac{\Delta p}{p}\right)^2, \text{ or } \left|\frac{\Delta Q}{Q}\right| \cong \frac{1}{\sqrt{n}} \left|\frac{\Delta p}{p}\right|. \quad (7)$$

Thus, the relative uncertainty in such a sum decreases inversely as the square-root of the number of terms in the sum.

When we purchase a measurement instrument, such as a luminance meter, the manufacturer will provide a statement of uncertainty  $U_m$  that is usually an expanded uncertainty with a coverage factor of  $k = 2$ —you must always check this with the manufacturer. The associated combined standard uncertainty is  $u_m = U_m/2$  is likely a root-sum-of-squares of the calibration uncertainty of their transfer standard (traceable to the appropriate national laboratory)  $u_c$ , the repeatability of the measurement of that standard  $s_m$ , and various other factors such as drift, temperature effects, focus, distance, etc. With luminance meters, since the repeatability is often much smaller than the uncertainty, the manufacturer may quote the repeatability of that instrument  $s_m$  to give you an idea of how well the instrument can make relative measurements in a short time period. Such an uncertainty statement and its related repeatability is often made in connection with a particular, CIE illuminant A, for example. How well the instrument does for other colors and sources may not be stated. Further, the stated uncertainty may only apply to luminances above a certain threshold. Thus, without clear specifications from the manufacturer, it may not be appropriate to apply the stated uncertainty of a luminance meter to low-light level readings.

### A108-1 Luminance Measurement Uncertainties

The manufacturer tells us that his instrument has a relative uncertainty of  $U_m/L = 4\%$  and a relative repeatability of  $s_m/L = 0.2\%$ . We will assume that this  $U_m$  is an expanded uncertainty with a coverage factor of  $k = 2$ . When we make a single measurement, the uncertainty of our measurement result would be  $U_m$ , that is, we will assume the repeatability has already be folded into the uncertainty. If we were to make several measurements of an absolutely stable light source in a short period of time, we would expect that the standard deviation of that set of results would be approximately the repeatability  $s_m$ .

Suppose we make several measurements of the luminance  $L_i$ ,  $i = 1, 2, 3, \dots, n$  and determine the mean  $L_{ave}$  and standard deviation  $s_L$  of the resulting set; but we find that the standard deviation is significantly larger than the repeatability of the instrument,  $s_L > s_m$ . What do we then use for the uncertainty? Obviously, there is some instability somewhere. If we cannot improve the apparatus to eliminate the increased uncertainty, then we must incorporate it into the uncertainty estimate that we would provide to characterize our measurement capability. The combined standard uncertainty is the root-sum-of-squares of the component uncertainties (see A221). Assuming the uncertainty of the LMD includes a  $k = 2$  coverage factor, we wouldn't use  $U_m$  as a component of uncertainty, but we would have to eliminate the coverage factor thereby using  $U_m/k = U_m/2 \cong u_m$  as the component of uncertainty that is associated with the instrument. The combined standard uncertainty for our luminance measurement would be

$$u_L = \sqrt{\left(\frac{U_m}{k}\right)^2 + s_L^2} = \sqrt{\frac{U_m^2}{4} + s_L^2}. \quad (8)$$

Finally, we reintroduce a  $k = 2$  coverage factor to obtain  $U_L = 2u_L$ , which is properly called the *expanded uncertainty with a coverage factor of  $k = 2$* . It is  $U_L$  that we would use in quoting the final uncertainty of our luminance measurement.

**Example:** With our above example of  $U_m = 4\%$  we will assume that the manufacturer used a  $k = 2$  coverage factor in establishing the measurement uncertainty of the LMD. Further, let's assume that the relative standard deviation of the set of measurements with respect to the average  $L_{ave}$  is  $s_L/L_{ave} = 1.2\%$ . Using Eq. 8, we would obtain  $u_L/L_{ave} = 2.3\%$ , and the relative expanded uncertainty with a coverage factor of  $k = 2$  would be  $U_L/L_{ave} = 4.6\%$ .



### A108-2 Chromaticity Coordinate Measurement Uncertainties

We have a similar situation as in the above luminance measurement, except that the repeatability of the chromaticity measurement is not necessarily much smaller than the uncertainty of measurement of the instrument. For a single measurement, we would be inclined to accept the manufacturer's uncertainty statement of  $U_m$ . Thus, when we make single measurements, we must be aware of the possibility of an increased uncertainty from random effects (type A—see A221) than we may find with the luminance measurement.

Let  $c$  be any one of the chromaticity coordinates. Suppose the uncertainty of measurement of the instrument is  $U_m = 0.0024$  and the repeatability is  $s_m = 0.0005$ . Also, suppose we take a series of measurements of the chromaticity coordinates of some source and find that the standard deviation  $s_c = 0.0015$  of those measurements. Since the standard deviation of the set is in excess of the repeatability, then we will want to account for it as another component of uncertainty. Assuming that the manufacturer uncertainty estimate  $U_m$  is an expanded uncertainty with a coverage factor of  $k = 2$ , then the combined standard uncertainty of any chromaticity measurement would be

$$u_c = \sqrt{\left(\frac{U_m}{k}\right)^2 + s_c^2} = \sqrt{\frac{U_m^2}{4} + s_c^2}, \quad (9)$$

or  $u_c = 0.0014$ . We would quote an expanded uncertainty of  $U_c = 2u_c = 0.0028$  with a coverage factor of  $k = 2$ .

### A108-3 Contrast Measurement Uncertainties

The error in the contrast  $C = L_w/L_b$  is based on a luminance measurement of white  $L_w$  and black  $L_b$ . The relative uncertainty in the contrast measurement is, from Eq. 6,

$$\left(\frac{u_c}{C}\right)^2 = \left(\frac{dC}{C}\right)^2 = \left(\frac{dL_w}{L_w}\right)^2 + \left(\frac{dL_b}{L_b}\right)^2 = \left(\frac{u_w}{L_w}\right)^2 + \left(\frac{u_b}{L_b}\right)^2, \quad (10)$$

where,  $u_c$ ,  $u_w$ , and  $u_b$  are the combined standard uncertainties associated with the contrast, the white, and the black measurement, respectively. Consider an example: The manufacturer quotes a relative uncertainty of measurement of  $R_m \equiv U_m/L = 4\%$  for the luminance  $L$  of a CIE illuminant A at  $100 \text{ cd/m}^2$ , which we will assume is an expanded uncertainty with a coverage factor of  $k = 2$ . They then say that the relative repeatability at this luminance level is  $r_m \equiv s_m/L = 0.1\%$ . Suppose also that the lowest the meter can read is  $0.01 \text{ cd/m}^2$  and that the readout error is roughly  $\delta L = 0.01 \text{ cd/m}^2$  because of the uncertainties associated with that last digit. Let's assume that the white luminance is  $L_w = 130 \text{ cd/m}^2$ . Suppose the black luminance measures  $L_b = 0.51 \text{ cd/m}^2$ . The contrast is  $L_w/L_b = 255$ , but what is the uncertainty in that contrast measurement?

If we only made a white luminance measurement, the uncertainty would be  $R_m L_w$ , that is,  $4\%$  of  $L_w$ . But when measuring contrast, we are going to combine the uncertainties of the white and black measurements. For this calculation, the standard uncertainty in the white luminance measurement is  $u_w = (R_m/2)L_w = 2.6 \text{ cd/m}^2$ , where the factor of two is from removing the effects of the  $k = 2$  coverage factor. (Once we calculate the combined standard uncertainty of the contrast, then we will use a  $k = 2$  coverage factor to obtain the final expanded uncertainty of contrast.) For the white measurement, the readout error is ignorable.

Naïvely speaking, the uncertainty in the black arises from the component of uncertainty associated with the instrument's calibration  $R_m L_b$  and the component of uncertainty associated with the readout  $\delta L = 0.01 \text{ cd/m}^2$ , which for black is not longer ignorable. If that were true—that the relative uncertainty  $R_m$  stays unchanged for low-light level reading—then the standard uncertainty in the black measurement would be given by

$$u_b = \sqrt{\left(\frac{R_m}{2} L_b\right)^2 + (\delta L)^2}, \quad (11)$$

or  $u_b = 0.014 \text{ cd/m}^2$ . In doing this we have made the assumption that the repeatability is not a factor with which we have to be separately concerned, that is, we have assumed that  $u_b$  adequately accounts for repeatability. Now, from Eq. (10) the relative combined standard uncertainty ( $u_c/C$ ) in the contrast is, naïvely,

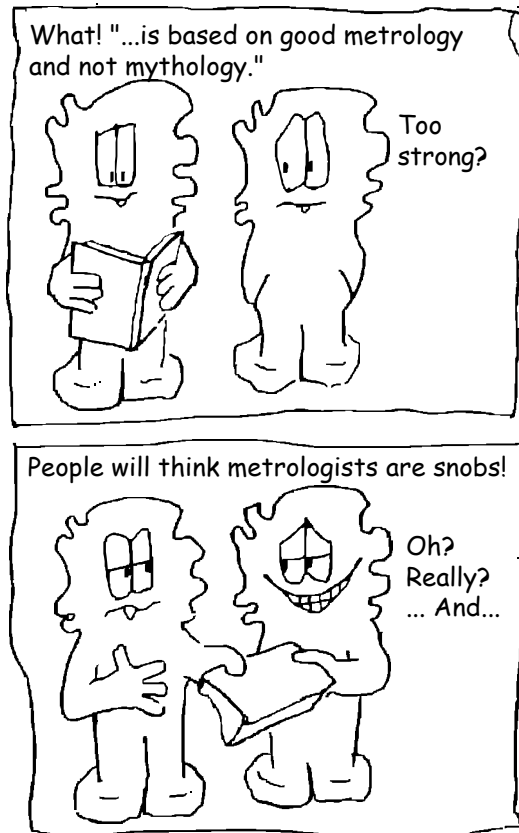
$$\left(\frac{u_c}{C}\right)^2 = \left(\frac{dC}{C}\right)^2 = \left(\frac{u_w}{L_w}\right)^2 + \left(\frac{u_b}{L_b}\right)^2 = (0.020)^2 + (0.027)^2, \text{ or } u_c/C = 3.4\% \quad (12)$$



We should use a coverage factor of  $k = 2$  so that the relative expanded uncertainty of the contrast measurement is  $R_c = U_c/C = 6.8\%$ . This calculation may seem adequate, but it probably is not. Here's why: *This naïve calculation hinges on the assumption that the  $R_m = 4\%$  relative uncertainty of measurement of the instrument and its  $0.1\%$  relative repeatability remains the same for dark measurements as it is for the brighter measurements (such as its calibration point of the CIE illuminant A). That is not necessarily true—in fact, it probably is not true. Unless the manufacturer can assure you of that fact or provide you with more uncertainty information that covers the lower-luminance levels, some attempt needs to be made to characterize the luminance meter for low light levels.* For example, suppose the detector has a noise of  $s_n = 0.1 \text{ cd/m}^2$  about the zero signal, but any negative results would always be truncated to zero in the output of the instrument. For measurements of luminances of  $100 \text{ cd/m}^2$  and above, that will permit a relative repeatability of  $0.1\%$  as stated in the specifications. The uncertainty in the white measurement is not affected by such noise, but the black is definitely affected. The combined standard uncertainty of black must add another component to account for this noise  $s_n$ . This is equivalent to including the measured repeatability of black as a component of the uncertainty in the result of a measurement:

$$u_b = \sqrt{\left(\frac{R_m}{2} L_b\right)^2 + (\delta L)^2 + s_n^2}, \tag{13}$$

or  $u_b = 0.10 \text{ cd/m}^2$  and the relative contribution to the contrast uncertainty is  $u_b/L_b = 0.20$ . The noise in the black measurement now becomes the dominant source of uncertainty in the contrast result. The uncertainty in the white measurement becomes ignorable by comparison ( $u_w/L_w = 0.020$ ), and essentially all of the uncertainty in the contrast measurement comes from the black measurement: With a coverage factor of  $k = 2$ , the relative expanded uncertainty in the contrast measurement result becomes  $40\%$ . This shows how important it is to understand the instrument's capabilities in making black measurements. However, there are further problems. In evaluating Eq. 13 we assumed that the relative uncertainty  $R_m$  doesn't change as the luminance decreases. Usually the uncertainty of an instrument decreases with the level of the signal measured—this is in addition to any readout errors encountered for low-level measurements ( $\delta L$ ). Thus, before an uncertainty in a contrast measurement can be evaluated, the performance of the instrument in measuring low-level luminances must be provided or determined. See A106 Detector Linearity Diagnostics for some pointers on testing for low-light-level measurement capabilities.





## A109 COLOR MEASUREMENT DIAGNOSTICS

Suppose you purchase an array spectroradiometer or a tristimulus colorimeter and a calibrated tungsten-halogen light source. You measure the source with your LMD and you get the proper luminance  $L_w$  as well as the proper chromaticity coordinates  $x_w$ ,  $y_w$  (or whatever color space you need to use). Yet when you look at the chromaticity diagram you realize that this is just one point in the gamut. Is there any way to be reasonably sure that the LMD will measure the other colors correctly without having a number of radiometrically calibrated lamps or filters? (Even if you don't have a calibrated standard light source, the failure of the LMD to perform these measurements may indicate a problem with the instrument.) If pure monochromatic light, such as from a laser, is measured, the chromaticity coordinates obtained from the instrument should fall very near or on the spectrum locus of a standard color space. Similarly, if a narrow-band interference filter is measured, then the measured chromaticity coordinate should also be close to the spectrum locus.

The distance from the measured chromaticity coordinates to the spectrum locus depends upon the bandwidth of the illumination, and the errors of the measuring instrument (see Fig. 1). Interference filters can provide an inexpensive and straightforward method to confirm the performance of spectroradiometers and colorimeters in measuring highly saturated colors. If the instrument can accurately measure several points along the spectrum locus (especially near 400 nm and 700 nm), and a known white point (such as from a calibrated source), and if the instrument is linear, then the operator should feel comfortable with the ability of the instrument to measure any point (color) within the spectrum locus.

A spectroradiometer or colorimeter with imaging optics views the central part of the interference filter. An aperture is provided to ensure that the edge of the filter is not used in the measurement (this outer diameter region is where the filter can be non-uniform). A light-transmitting diffuser made of opal glass is used to provide uniform illumination. An optional neutral density filter can be used to attenuate the light if it is too bright or to test the uniformity of the results with a change in light intensity. The light source can be an incandescent lamp or an integrating sphere source.

A simplified geometry of the apparatus is shown in Fig. 2. There are at least three sources of errors associated with the measurement configuration: the characteristics of the interference filter (bandwidth, temperature coefficient, drift), the dispersion introduced by light which is not parallel to the normal of the interference filter, and an overall error in establishing the normal direction of the interference filter. These errors would cause the data to shift from the calculated values, although if care is taken, the dispersion and alignment errors can be made negligible. Any background light or scattering within the instrument could be an additional factor. Finally, how the instrument handles any background subtraction may also be a factor revealed with the use of interference filters. Using a spectroradiometer, a substantial signal for frequencies far removed from the interference filter peak can indicate undesirable scattering within the instrument. A He-Ne laser (e.g.  $\lambda = 632.8$  nm) is also a good way to check for unwanted scattering.

The most rigorous way to evaluate the measured results would be to have the interference filters calibrated for spectral transmittance

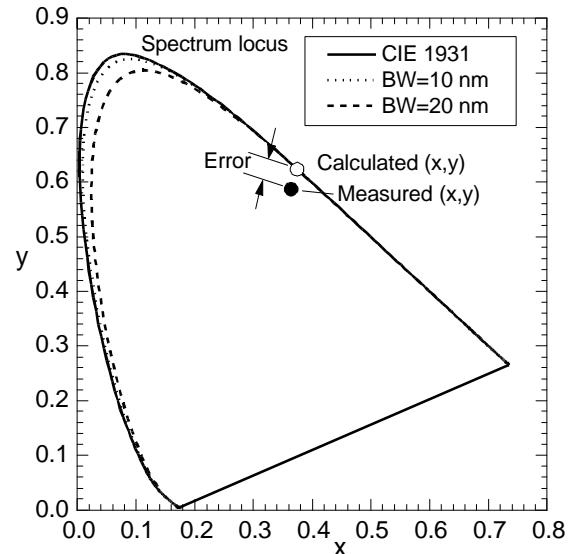


Fig. 1. Spectrum Locus

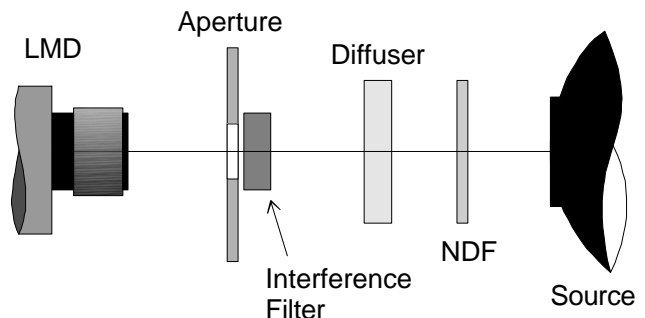


Fig. 2. Apparatus. Separations of filters and diffuser from the source are exaggerated for illustration purposes. Since the absolute luminance level is not important, the filters may be placed close to the exit port to minimize the generation of stray light.



immediately before measurements are made, and compared with the calculated chromaticity coordinates. When this method is not available, data provided by the filter manufacturer can be used. When the manufacturer's data are used, one should consider that the filter characteristics are subject to long-term drift and temperature dependency.

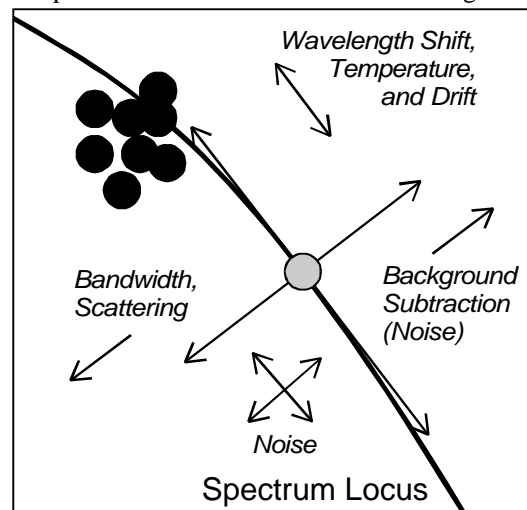
In a typical configuration we arrange the elements as shown in Fig. 2. We set the distance between the LMD and the interference filter to be from 50 cm to 1 m, depending upon the instrument. A filter holder is chosen to ensure that each filter used is placed in the same position. We use the reflection of the lens of the LMD in the interference filter to align the optics. Once this alignment is made, the holder is not repositioned. We eliminate background illumination as much as possible by shrouding the apparatus with black felt to avoid any stray light. Be careful that the interference filter is not heated by environment. It is best to put the highly reflective side of the interference filter facing the source to minimize any heating. The diffuser is not necessary if an integrating sphere is employed.

**Procedure:** The luminance and chromaticity coordinates should be recorded for a selection of interference filters (with bandwidth less than 10 nm) and plot the data on the chromaticity diagram to see how close they come to the spectrum locus. In the case of the spectroradiometers, the dominant wavelength, spectral purity, radiometric transmittance, and spectral response can also be recorded. Enough readings should be taken for each filter to obtain some understanding of how well the LMD deals with saturated colors. The greatest difficulty in reaching the Locus will likely be found nearest the ends of the visible spectrum (400 nm and 700 nm).

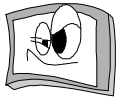
#### SOURCES OF ERROR:

As stated earlier, if the LMD is properly calibrated for obtaining the correct color of a standard white point (e.g. CIE illuminant A), and if the measured colors of the interference filters fall on or near the spectrum locus, then all other colors within the color gamut should be measured accurately by the device. If the interference-filter data points shift away from the locus more than their bandwidth would permit, then make sure care has been taken with the alignment of the apparatus, and good interference filters chosen. Also, check for stray light contributions to the measurement. Look for any stray light (not the light from the interference filter) illuminating the front of the LMD that would appear in a reflection off the interference filter. The bandwidth of the filters can account for some displacement from the locus toward the center of the color gamut (see Fig. 1, bandwidth especially affects the displacement in the green region). If all these sources of error are accounted, then the location of the measured data point with respect to the spectrum locus can provide some information on the behavior of the instrument.

Figure 5 shows a small segment of the spectrum locus (around 530 nm) and some data points. If the measured data does not fall on the ideal point on the locus, its position in reference to the "true" point can indicate possible sources of error. Shifts along the spectrum locus could result from calibration errors, or indicate a mismatch of filters in tristimulus colorimeters. Shifts toward the white point would indicate internal scattering of light within the measuring device, possibly stray-light leakage (including infrared), and inadequate subtraction of a background signal. Detector noise could cause the data to fall on either side of the locus. Some devices subtract a no-light background from the light measurement and can lead to negative readings owing to noise. If any negative data is truncated, the resulting chromaticity-coordinate data points could shift slightly inward. Thus, if good filters are used and care is taken with the setup, the placement of the data in relation to the locus can indicate how the instrument performs with respect to its specifications and your own expectations.



**Fig. 5.** Sources of error that can move a data point away from its ideal position on the spectrum locus.



## A110 TEMPORAL RESPONSE DIAGNOSTICS

The temporal response of any light measuring device (LMD) used in the procedures outlined in this document may be checked to assure accurate measurements. The methods described in this section are effective for checking the temporal response of devices such as photodiodes and photomultiplier tubes whose output can be measured directly. The temporal response of a LMD is determined by measuring the response of a LMD to a light pulse. Light pulses of a known duration and rise time can be formed using a He-Ne laser and a light chopper or a pulse generator and an LED.

### CHOPPER AND LASER:

The light beam from the laser passes through the chopper and into the entrance port of an integrating sphere whose exit port faces the LMD under test. (This need not be a laboratory grade integrating sphere. Almost any enclosure with a white interior having two appropriate ports will do.) The reason for using an integrating sphere is to prevent damage

to your LMD by directing the laser beam directly into the LMD. The period of the light pulse must be of sufficient duration to measure the response of the LMD. The best that can be done for equal on and off times of the pulse is by using two openings (to balance the chopper) with an arc length of  $90^\circ$ . To ensure that you are measuring the response time of your LMD the light pulse is required to have a rise time much less than the response time of the LMD under test. To achieve a light pulse with a minimum rise time the light chopper should be positioned where the laser beam has the smallest cross section; i.e., as close as possible to the output laser. Otherwise, divergence in the beam will cause the beam to spread giving the light pulse a longer rise time. Also, the beam should be close to the rim (outer diameter) of the chopper; the higher the angular velocity of the opening the shorter the rise time of the pulse.

As an example, supposed the laser beam has a diameter of  $d = 1$  mm and passes through the chopper at a distance of  $x = 20$  mm from the axis of the wheel. The rotation angle associated with this width of the laser beam would be  $q = d/x = 1\text{mm}/20\text{mm} = 0.05$  radians. If we assume we have a chopper with a rotation rate of  $R = 10$  rps (revolutions per second:  $60\text{ rpm} = 1\text{ rps}$ , where rpm = revolutions per minute) then the angular velocity would be  $w = 2\pi R = 63$  radians/sec. Therefore, the rise time of the light pulse would be  $q/w = 790\ \mu\text{s}$ ; at  $R = 100$  rps (6000 rpm) the rise time of the light pulse would be  $79\ \mu\text{s}$ .

### LED AND PULSE GENERATOR:

Another way to test the temporal response of the LMD is to power a fast LED with a good pulse or square-wave generator. This is especially important for testing response times in the submicrosecond and nanosecond regimes. Fast LEDs are readily available (response times in the nanoseconds). They can be tested using a fast photodiode or fast PMT (photomultiplier tube). Watch out for proper termination of the cable connecting the LED to the generator (or proper output impedance of the generator) so that reflections in the cable don't interfere with the measurement—this is especially important if you are worried about submicrosecond measurements. (Some display technologies require a submicrosecond response times, so such reflections can pose a problem.) For submicrosecond pulses, substantial voltages ( $> 10\text{V}$ ) may be required to make the LED light pulse sufficiently bright to be seen or measured.

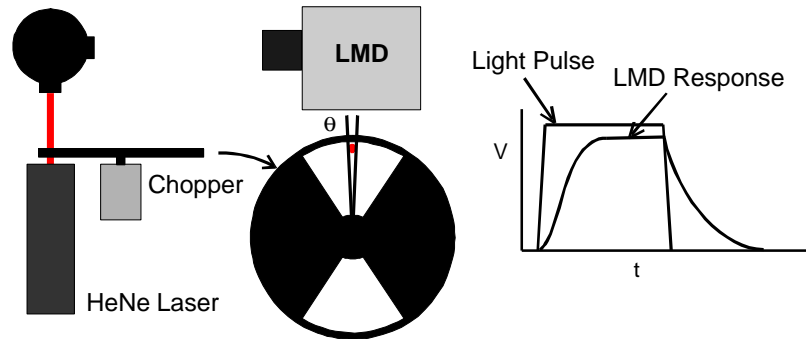
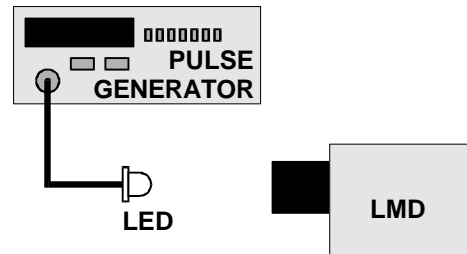


Fig. 1. Chopper and laser apparatus for measuring response times.





## A111 ARRAY DETECTOR MEASUREMENTS

In addition to the general requirements already outlined in A103, there are complications in using array detectors such as CCDs. There are several sources of error associated with array detectors. Here we are talking about the entire imaging system including the lens, we are not limiting all our remarks to the array element by itself. You can have a perfect CCD with exactly the same response for each array pixel. But when it is put into a system with a lens, the entire imaging system likely no longer preserve that uniformity because of the performance of the lens, reflections, etc. Thus, there are several factors to consider when using an array photodetector:

- (1) **Nonuniform response over array.** This is the nonuniform responsivity from pixel to pixel in the photodetector array including any nonlinearity and differing linearities in response for pixels or columns of pixels. There can be defective detector pixels and small regions where the response is different than the average response. Many of these problems can be accounted for via a flat-field correction (5).
- (2) **Nonuniform imaging from lens system.** The properties of the lens used which contributes to nonuniformity such as vignette (the  $1/\cos^4$  fall off, see A213) and shutter vignette. Shutter vignette can be observable when a mechanical shutter is used with the array detector and not all parts of the array receive the same exposure—this can be a problem especially for short exposures. There are other problems encountered with lens systems, such as the change in image luminance with focus.
- (3) **Glare, veiling glare, lens flare.** The lens system and the components associated with it often produce a stray light that provides a nonuniform background illumination that depends upon the scene being viewed as well as the lens configuration (e.g., different f-stops).
- (4) **Background subtraction.** Appropriate background signal needs to be subtracted from any acquired signal. If the array is not thermally regulated, backgrounds need to be measured often.
- (5) **Flat-field corrections.** Appropriate correction needs to be made for the nonuniformity of system response whenever the most accurate measurements are required. The flat-field correction provides a detector pixel-by-pixel adjustment so that all the detector pixels have the same response to the same amount of light. It is usually an array of numbers that multiplies the measurement array after background subtraction to adjust for nonuniformities of the entire system. The problem here is creating the appropriate arrangement to provide a uniform source from which a uniformity calibration can be made.
- (6) **Photopic response.** For luminance measurements a photopic filter is required. This assumes that each detector pixel has the same spectral responsivity (this may not always be the case).
- (7) **Aliasing between the detector pixel and the display pixel.** When the spatial frequency of the image of the display pixel is anywhere near the spatial frequency of the detector pixel, you can get aliasing and a resulting modulated picture. Defocusing the lens or putting a diffusion filter (from a camera store, for example, or glass plate with some hair spray on it) in front of the lens may help, but this may not be a reproducible way to regulate the light.
- (8) **Calibration in luminance.** If the array detector, such as a CCD, provides you with counts and you need luminance values instead; then the array detector must be calibrated. Measure the same uniform source with the array LMD and a luminance meter—the exit port of an integrating sphere works well, or use a white diffuse standard. Let  $L$  be the luminance measured by the luminance meter and  $S$  be the value obtained from the array LMD. The correction factor is  $c = L/S$ , and future measurements by the array detector can be converted to luminance by multiplying the array LMD values by  $c$ .

When we speak of linearity, we mean the output from each detector pixel  $S_i$  is related to the luminous flux hitting the detector pixel by  $S_i = m_i F + b_i$  where  $m_i$  is independent of flux  $F$  for all the detector pixels. The background subtraction removes  $b_i$ , and the flat-field correction  $k_i$  produces the same response for each pixel, or  $k_i m_i = m = \text{constant}$ . To achieve a uniform response the response of the detector pixel  $S'_i$  is corrected according to  $S'_i = (S_i - b_i)k_i = mF$ , for all array detector pixels. As long as  $m_i$  is not a function of  $F$  this will be a successful operation. Of course the background and the signal are both noisy, so this will never work perfectly.

Given that each detector pixel can be corrected to assure uniformity for any particular system and object (the DUT) configuration, lens flare or veiling glare is still a particular concern. In general, the amount of glare depends upon the lens used and the configuration of the detector, but it also depends upon the size and position of the light sources being measured. You can get a different glare simply by moving the object (the DUT) closer so that the object being measured (the DUT) subtends a larger solid angle. What this means is that the flat-field



correction with one configuration may not be adequate for another configuration. Changing the f-stop of the lens (aperture), the position of the light source (the DUT), the pattern of light on the screen, etc., all affect the glare contribution to the array. Hopefully, you will be fortunate so that all these problems represent only a few percent error in measured light.

How can we tell if we have a problem? Ideally if we had a uniform light source that was an exact replica of the light we were trying to measure, we could make a good flat-field correction (FFC). For example, suppose you wanted to measure the uniformity of the entire surface of a DUT with a CCD camera, and suppose the CCD is perfect and linear. If we setup the DUT, determined the position and size of the white full screen to be measured, then removed the DUT and replaced it with a uniform light source that had the same shape as the white screen and was placed at the exact same position, then we could produce a flat-field correction that accounts for the imperfections of the system for that particular configuration. Such a light source is generally not available.

If you are fortunate enough to have a lens with very little veiling glare, you may be able to create one FFC and use it with many configurations. Here is an example of a procedure to test how well one FFC will work. It assumes adequate image processing software is available to manipulate the images as desired. Using a quality integrating sphere with an exit port luminance nonuniformity of 1 % or less. Place it a distance away from the array detector system so that the image of the exit port is slightly larger than the array when the exit port is in sharp focus (you will have to move the integrating sphere off axis a little to focus on the exit port)—the goal is to fill the image of the exit port with the array as much as possible. Adjust the light source so that you are getting readings well above the background but not saturating the detector array. For example, if the maximum counts attainable per CCD detector pixel is 16,384 before saturation, a luminance that produces 10,000 counts or so would be reasonable.

Take a background image  $B(x,y)$  with the lens cap on the lens (or equivalent). (It may not be sufficient to simply take a background with the shutter closed if the shutter-closed background is different from the background taken with the lens cap on the lens, it is best to use the background with the lens cap.) Then obtain a raw image of the exit port  $R(x,y)$  and subtract off the background image to obtain the net image  $N(x,y)$ . Obtain the average of the net image for all pixels:

$$m = \frac{1}{n} \sum_{\text{image}} N(x, y),$$

where there are  $n$  total detector pixels. The FFC is given by  $F(x,y) = N(x,y)/m$ , and will be approximately equal to one for all FFC pixels. Now, all future images can be corrected  $C(x,y)$  using the background and FFC by

$$C(x, y) = [R(x, y) - B(x, y)] / F(x, y).$$

To see how well this FFC works for other situations, change the position of the integrating sphere; move it nearer to the lens and further away obtaining a series of raw images for each position. Be sure the focus is always made on the exit port of the integrating sphere. Include one image of the exit port far enough away that it fills less than half the array. You can also change f-stops if that is possible on your system. Obtain the corrected images for all the different positions of the integrating sphere  $C_i(x,y)$  and examine how uniform the exit port is found to be in all the images. Any nonuniformity you observe in the exit port images is an indication of the upper bound of the usefulness of your FFC. If in the distant image you find the exit port shows a 5 % nonuniformity, or the near focus image shows a nonuniformity of 10 %, then you cannot use that FFC for all measurements from which you expect accuracy. Further, you will have to take a FFC for each configuration you want to use. It would be difficult to create a uniform luminance surface the size of the display at the same position that the display is to be measured. Hopefully, you will find the FFC to be able to provide you with a less than 2 % nonuniformity for the display images that are approximately the same size as the image used to create the FFC.



## A112 IMAGES AND PATTERNS FOR PROCEDURES

### A112-1 Setup Targets

The following targets (patterns and images) can be employed to setup the display if the manufacturer does not provide specifications to do so or if the specified setup is found to be inadequate for the use of the display. Slide 4 provides a 32 level gray scale on each side as well as concentric square targets with the top most and bottom most six levels. If the display provides adjustments of, say, contrast, the objective would be to adjust for the visibility of the greatest number of gray levels near white and black. In all scenes and faces there is a 32 level gray scale at the bottom of the screen and the concentric boxes on the right side.

#### RENDERING GRAY LEVELS:

Gray levels can be specified by bit-levels in a digital system or voltage levels in an analog system. Establishing the analog voltages required is straightforward (see below). However, the digital process can be confusing. In digital systems we often don't want to view each available gray level, but we often want an evenly spaced subsample of the available gray levels to measure performance. When we have to extract fewer evenly spaced levels from a larger set of levels, it is not as straightforward as many think.

**Bit Levels in Software:** Given  $n$  levels of gray that can be displayed on a screen, with 0 for black and  $w = n - 1$  for white. We want to select a subset of  $m$  levels that are as evenly spaced as possible from this larger set of  $n$  levels. The interval between the  $n$  levels to create  $m$  levels is  $\Delta V = w/(m-1)$ , which may not be an integer. So, the levels to select are the (integer) values of  $V_i = \text{int}[(i-1)\Delta V]$  for  $i = 1, 2, \dots, m$ , or  $V_i = 0, \text{int}(\Delta V), \text{int}(2\Delta V), \text{int}(3\Delta V), \dots, \text{int}[(m-1)\Delta V]$ , with  $\text{int}[(m-1)\Delta V] = w$  for white. For example, if there are  $n = 256 = 2^8$  levels from which we select  $m = 8$  levels, white is  $w = 255$ ; the interval is  $\Delta V = 36.4286$ , and the chosen levels are: 0, 36, 73, 109, 146, 182, 219, 255. Similarly, the levels selected out of a 16 bit gray-scale  $n = 65535 = 2^{16}$  for  $m = 16$  levels, gives a spacing of  $\Delta V = 4369$ , and the levels are 0, 4369, 8738, 13107, etc., up to 65535. If we wanted  $m = 32$  levels instead, the spacing is  $\Delta V = 2114.0323$  giving levels 0, 2114, 4228, 6342, 8456, 10570, etc. up to 65535. If we only had  $n = 256$  possible levels available and we want to select  $m = 32$  levels, we'd use  $\Delta V = 8.2258$  to give: 0, 8, 16, 25, 33, 41, 49, 58, 66, 74, 82, 90, 99, 107, 115, 123, 132, 140, 148, 156, 165, 173, 181, 189, 197, 206, 214, 222, 230, 239, 247, 255.

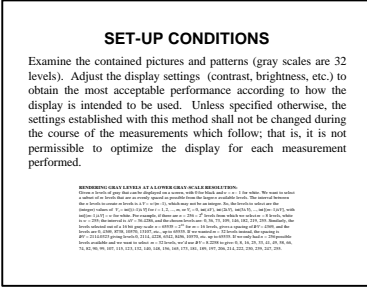
**Analog Signal Levels:** For analog signals, if  $V_w$  is the white level and  $V_b$  is the black level, then for  $m$  levels the signal step size is  $\Delta V = (V_w - V_b)/m$  and  $V_j = V_b + j\Delta V$ .

#### GRAY LEVELS IN PERCENT OF WHITE:

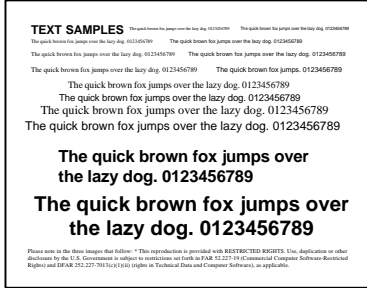
Slide #8 in the setup slide set is modeled after SMPTE RP 133-1991 (see "SMPTE Recommended Practice: Specifications for Medical Diagnostic Imaging Test Pattern for Television Monitors and Hard-Copy Recording Cameras," SMPTE Journal, pp. 580-582, July 1991). There use is made of a gray scale based upon an analog signal in percent of the difference between the white signal level and the black signal level. The file FPDMSU.\* shows what it should look like with the additions we have made appropriate for the considerations in this document. However, you will want to use the bit-mapped version of this pattern found in FPDMSUBM.ZIP for the appropriate screen pixel addressability (640x480, 1024x768, 1600x1204, etc.). A perfect correspondence between the percent gray-scale and the 256-level gray scale cannot be obtained to perfectly match the SMPTE pattern. We propose the following rule to get approximate bit-levels in a  $n = 256$  gray scale with white specified by  $w = n - 1$  and 0 for black: The bit level  $V$  associated with the SMPTE percentage  $p$  (fractional quantity) is  $V = \text{int}(wp) = \text{int}(255 \times \text{percentage}/100\%)$ . This amounts to rounding all the fractional values down. We have added single pixel and double pixel checkerboards for black-and-white pixels and pixels at the levels of 53 % and 48 % (bit levels 135 and 122)



Selection of levels from $n = 2^{16} = 65536$ levels									
64 Gray Levels		32 Gray Levels		16 Gray Levels		8 Gray Levels		4 Gray Levels	
$\Delta V=1040.23\dots$		$\Delta V=2114.03\dots$		$\Delta V=4369$		$\Delta V=9362.14\dots$		$\Delta V=21845$	
Level	Value	Level	Value	Level	Value	Level	Value	Level	Value
1	0	1	0	1	0	1	0	1	0
2	1040								
3	2080	2	2114						
4	3121								
5	4161	3	4228	2	4369				
6	5201								
7	6241	4	6342						
8	7282								
9	8322	5	8456	3	8738				
10	9362					2	9362		
11	10402	6	10570						
12	11443								
13	12483	7	12684						
14	13523			4	13107				
15	14563	8	14798						
16	15604								
17	16644	9	16912						
18	17684			5	17476				
19	18724	10	19026			3	18724		
20	19765								
21	20805	11	21140						
22	21845			6	21845			2	21845
23	22885	12	23254						
24	23925								
25	24966	13	25368						
26	26006			7	26214				
27	27046	14	27482						
28	28086					4	28086		
29	29127	15	29596						
30	30167			8	30583				
31	31207	16	31710						
32	32247								
33	33288								
34	34328	17	33825	9	34952				
35	35368								
36	36408	18	35939						
37	37449					5	37449		
38	38489	19	38053						
39	39529			10	39321				
40	40569	20	40167						
41	41610								
42	42650	21	42281						
43	43690			11	43690			3	43690
44	44730	22	44395						
45	45770								
46	46811	23	46509			6	46811		
47	47851			12	48059				
48	48891	24	48623						
49	49931								
50	50972	25	50737						
51	52012			13	52428				
52	53052	26	52851						
53	54092								
54	55133	27	54965						
55	56173					7	56173		
56	57213	28	57079	14	56797				
57	58253								
58	59294	29	59193						
59	60334								
60	61374	30	61307	15	61166				
61	62414								
62	63455	31	63421						
63	64495								
64	65535	32	65535	16	65535	8	65535	4	65535



Slide 1. Explains the use of the setup slides and how the 32-level gray scale is established.



Slide 2. Positive of text (black text on white screen, like paper).



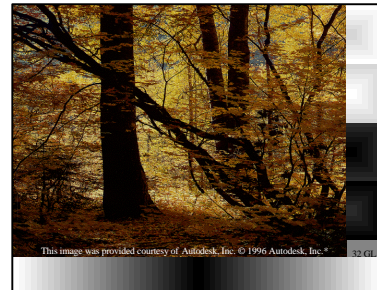
Slide 3. Negative of text (white text on black).



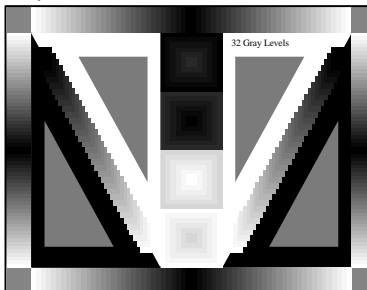
Slide 4. Faces will likely restrict the range of adjustment to a smaller range than the adjustment for a good gray scale only.



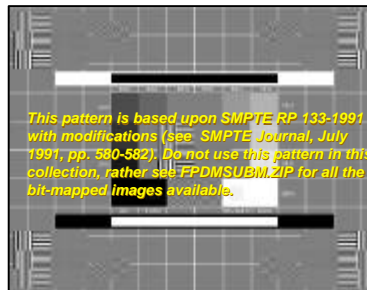
Slide 5. Mountain scene. If adjustment is available this scene will likely allow a wide range of adjustment and still be acceptable.



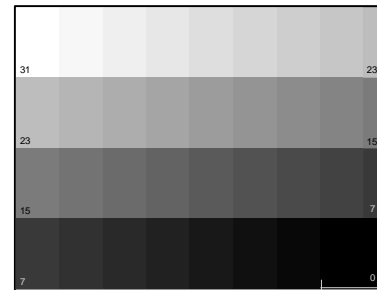
Slide 6. Autumn scene, many darks, but a wide range of adjustments will be tolerated here as with the mountain scene.



Slide 7. Presentation of 32 gray levels. Gray scales on the borders can reveal viewing angle problems.



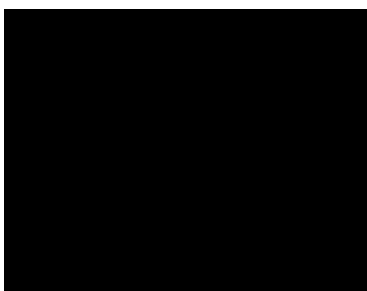
Slide 8. Pattern based upon SMPTE RP 133-1991 with modifications..



Slide 9. Stepped gray levels for quick measurement of gray scale. Note: this is not an accurate way to measure gray scale because of nonuniformities.



Slide 10. White full screen.



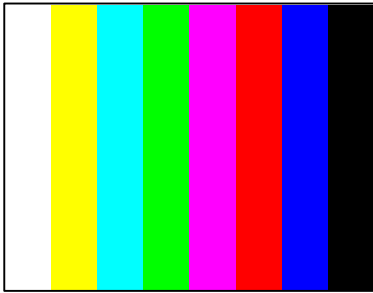
Slide 11. Black full screen.



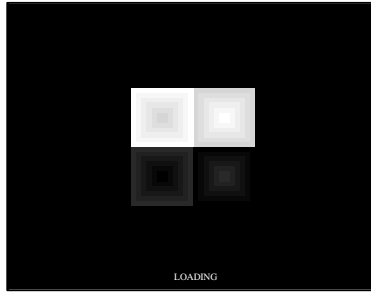
Slide 12. Dark-gray full screen.



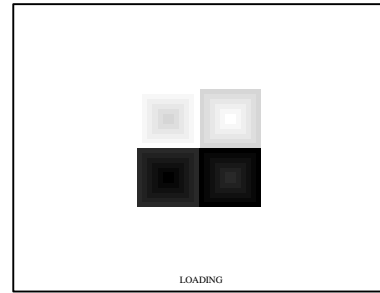
METROLOGY



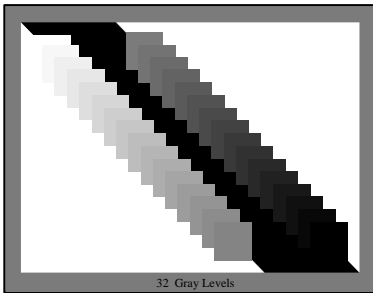
Slide 13. Saturated color bars in increasing luminance from left to right.



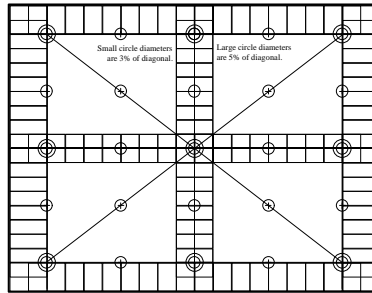
Slide 14. Ends of gray-scale on black screen. Look for loading effects.



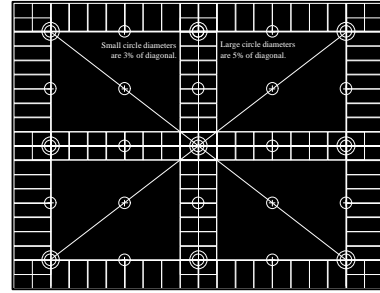
Slide 15. Ends of the gray-scale on white screen. Look for loading effects.



Slide 16. Stepped gray levels (32). Duplications are easy to see.

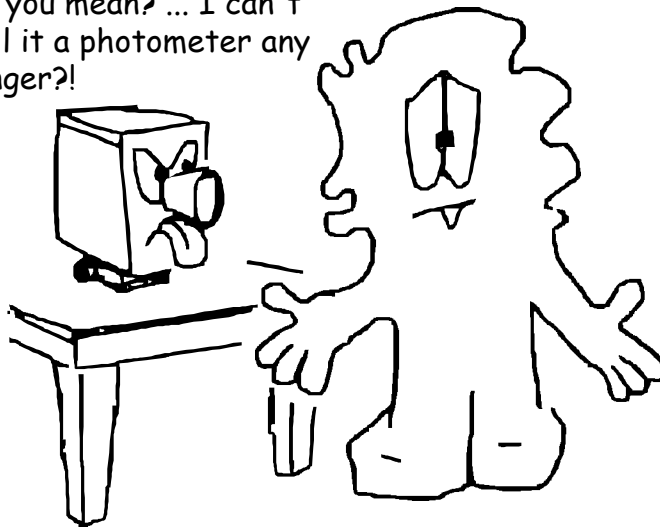


Slide 17. Centering and alignment target for 5, 9, and 25 sampled positions. Small circles are 3% of diagonal, large are 5%.



Slide 18. Negative of slide 12.






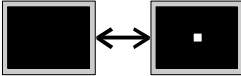







Luminance meter! What do you mean? ... I can't call it a photometer any longer?!





## A112-2 Patterns for Suite of Basic Measurements

Here are types of screens used in the measurements contained in the SBM.

- 302-1 Luminance and Color of Full-Screen White 
- 302-2 Luminance and Color of Full-Screen Black 
- 302-4 Color Gamut of Full Screen 
- 302-5 Gray Scale of Full Screen 
- 303-4 Shadowing (Gray Scale Artifacts) 
- 305-1 Response Time 
- 306-1 Sampled Uniformity of White 
- 306-2 Sampled Uniformity of Black 
- 306-4 Sampled Uniformity of Color 
- 307-1 Four-Point Viewing Angle Check 
- 308-2 Ambient Contrast 
- 401-1 Power Consumption 
- 402-1 Frontal Luminance Efficiency  (use 401-1 with white screen)

Note on 303-4: The last three screen patterns are examples. You must change them according to the worst-case observed in the first eight patterns. It was not practical to include all possibilities (it would require 560 images).



## A113 AUXILIARY LABORATORY EQUIPMENT

In addition to the LMDs used to perform the colorimetric measurements in this document and any signal generation equipment, oscilloscopes, and other electronics, there are several other objects and instruments which are mentioned and are found to be useful.

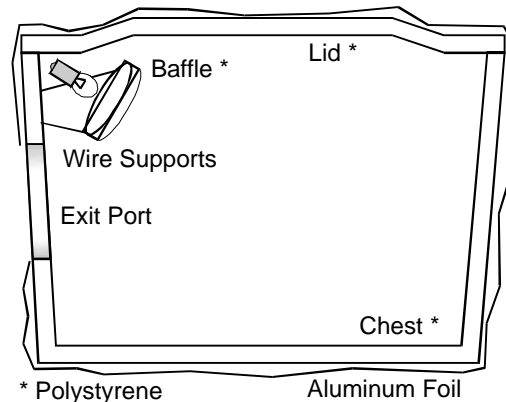
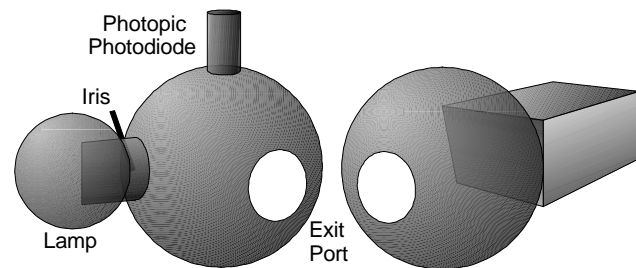
### SOURCES OF UNIFORM AMBIENT ILLUMINATION:

Usually these are used in characterizing the reflection performance of a DUT (see 308 Reflections). This is difficult to do without using an integrating sphere. A hemispherical structure larger than the display with several illuminators (at least two) that can be placed behind the plane of the surface of the screen may suffice depending upon what is to be measured. By using a variety of configurations you can also approximate such uniform ambient sources. How careful one needs to be depends upon the reflectance properties of the screen being measured. A polystyrene foam picnic cooler may be tried as well. Remove the lid and turn the opening facing the display on the perpendicular. A measurement aperture can be cut in the back (bottom) to permit measurements. Two lamps near but behind the plane of the display surface should allow you to illuminate the interior of the box relatively uniformly. Be careful that the lamps don't heat the display and affect performance. Some have been able to find hemispherical polystyrene structures that are smaller than the screen, but they add discrete light sources at the edges of the hemisphere so that the lights don't directly illuminate the screen (using a baffle). Methods using a small integrating sphere are under investigation.

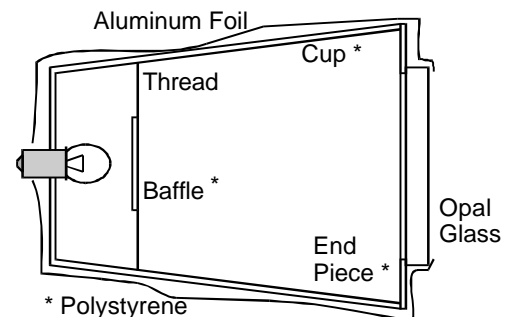
### UNIFORM LIGHT SOURCES

**Integrating Sphere Light Source:** An integrating sphere light source can be useful in several ways: 1) It can provide a source of calibrated luminance provided, of course, that it has been properly calibrated. 2) It can provide a source of luminance which is uniform over the exit port. Conventional wisdom suggests an exit port diameter of  $1/3$  the sphere diameter or less will provide a  $\pm 1\%$  to  $\pm 2\%$  nonuniformity of luminance across the exit port if the interior of the integrating sphere is covered with a diffuse white reflectance material having a 96% reflectance or greater. This source is very handy for many diagnostics (see A101-1, A106, A107, A109 for examples). If you are focusing on the source, always focus on the exit port of the integrating sphere. If it is well designed, its stability over long periods of time can be impressive, and its uniformity can hardly be replicated with other sources. A real pleasure to use.

**Small Polystyrene Cup Source:** The light source is constructed from an ordinary white foam-plastic (polystyrene) cup, an opal glass, and a 3 V to 6 V halogen flashlight lamp. A hole is made in the base of the cup through which the halogen lamp is placed. A white baffle just large enough to mask the bulb from shining directly on the hole for the opal glass is suspended in front of the lamp by human hair, wire, or thread (use a minimum of three to support the baffle). The purpose of the baffle is to prevent any hot spot of the halogen lamp from imaging on the opal filter. The opal glass produces a quasi-uniform diffuse light source. This source will not have the uniformity or the stability of a well-designed integrating-sphere source. If you attempt to adjust the luminance by changing the current through the bulb you will also change the spectral distribution of energy in the emitted light.



\* Polystyrene                      Aluminum Foil

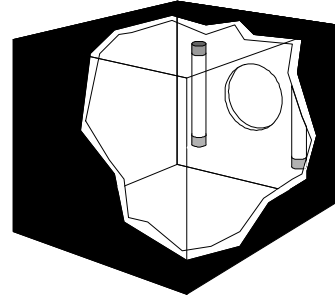


\* Polystyrene



**Picnic Cooler Polystyrene Source:** Picnic coolers made of white polystyrene foam can be used to make a relatively uniform large-diameter source (150 mm diameter). A large hole (150 mm diameter or so) can be cut in one of the sides at the long end of the cooler. In the two interior corners at the top of the cooler (where the lid is placed) position two tungsten-halogen bulbs away from the foam surface (so it doesn't melt). Position a white baffle (from a foam cup) in front of the bulb (but not too close) so that the bulb does not directly illuminate the interior face opposite the hole. Wrap the exterior surface and the exterior surface of the lid with aluminum foil (or paint it if you can) to make the box opaque. This source can exhibit about a 5 % uniformity across the exit port (hole). When focusing on the source, always focus on the plane of the exit port and not the back of the box. This way, small imperfections will be out of focus and less problematic.

**Box Source:** A large box (cube) with its interior painted with the brightest matte white paint available in a hardware store can be used for a large-diameter source. The exterior is usually painted matte black. A hole is cut in the center of one face and a large fluorescent circular light is placed behind the hole. Unless the fluorescent light is powered with high-frequency ac (as are many LCD backlights), there will be a power-frequency oscillation that can affect short measurements. Similarly, properly baffled tungsten-halogen bulbs may also be used with dc power. The bulbs can be placed in each interior corner of the face with the hole. The bulbs should be mounted away from the painted surface since they get rather hot. Place a round white flat baffle (made of polystyrene foam, for example) in front of the lamp so that the lamp doesn't directly illuminate the interior face of the box opposite the hole. Be careful not to place the baffles too close to the hot bulbs.



#### RONCHI RULING:

A Ronchi ruling is a glass substrate with black opaque (or chrome) lines of width equal to the line spacing between black lines. They are used to: 1) test for adequacy of spatially-resolved high-contrast luminance measurement capability, and 2) provide spatial calibration of an array photodetector.

#### NEUTRAL DENSITY FILTERS:

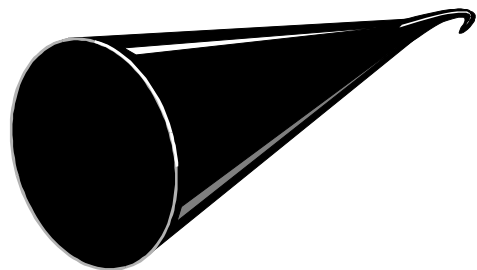
Neutral-density filters (NDFs) are used to decrease high-intensity light from overdriving or saturating the LMD and to extend LMD measurement integration time to avoid temporal aliasing with a refreshed display. There are generally two types. One is made of semi-transparent glass, and the other is made from evaporated metals. The deposited metal types tend to modify the spectrum of the transmitted light to a much lesser degree than some of the semi-transparent glass materials, however they sometimes have small pinholes or can be scratched if they are not coated with a protective coating. Keep the spectral modification in mind if either accurate photometric or colorimetric measurements are to be made for the density of the filter can change with the spectrum of the illumination. The transmittance  $T = L_{\text{NDF}}/L_0$  is related to the density  $D$  by:  $T = 10^{-D}$ ,  $D = \log T = \log_{10} T$ .

#### REFLECTANCE STANDARD:

Diffuse white reflectance standard samples can be obtained with luminance factor of 96 % or better. Some materials can be carefully sanded (some require water with the sanding) or cleaned to refresh the surface back up to its maximum reflectance should the surface become soiled or contaminated. Such reflectance standards can be used for: 1) Measurements of darkroom quality in the vicinity of the display surface. 2) Measurements to determine the reflectance properties of the display surface. 3) Measurements of illuminance from a luminance measurement of the standard ( $E = \pi L_{\text{std}} / r_{\text{std}}$ ).

#### CONE LIGHT TRAP:

These can be made from thin black gloss plastic. They can be used to provide a source of deep black for determining the zero offset of any instrument. Round cones are best (shown), but square cones are also useful. For the best performance it is helpful that there not be a dimple at the apex to reflect light. With plastic it is possible to squeeze the apex flat and bend it around upon itself to avoid the dimple.



**GLOSS BLACK PLASTIC:**

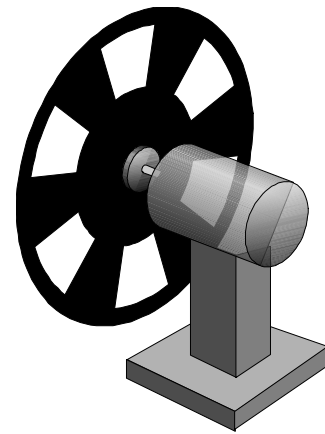
Gloss-black plastic is used to make cone masks, flat masks, replica masks, light traps. These items are useful in diagnosing glare and other problems in the optical system. Such black targets serve as reference blacks provided they are not reflecting illuminated areas in the room into the LMD. These can also be used to cover reflecting surfaces. Vinyl plastic having a thickness of 0.25 mm (0.010 in) is easily shaped, bent, and cut with scissors or a knife. Vinyl plastics having a thickness of 0.75 mm (0.030 in) are stiff and best for making flat surfaces that you don't want to bend easily. Check local listings for plastic suppliers to obtain sheets.

**MATTE BLACK PLASTIC:**

Matte-black plastic is used in making masks and black targets to diagnose glare or other problems where a gloss black target is impractical or would reflect too much light into the lens, for example, when the lens is very close to the target. These can also be used to cover reflecting surfaces. Vinyl plastic having a thickness of 0.25 mm (0.010 in) is easily shaped, bent, and cut with scissors or a knife. Vinyl plastics having a thickness of 0.75 mm (0.030 in) are stiff and best for making flat surfaces that you don't want to bend. Check local listings for plastic suppliers to obtain sheets.

**CHOPPER :**

A chopper is useful in running diagnostics on temporal response measurements of light detectors used in conjunction with a stable laser. Additionally, a clear plastic disc can also be mounted instead of the chopping disc for reducing the coherence of a laser beam (to reduce the speckle in the reflected light, for example). Spray the disk with a workable fixative available in an art supply store heavier on the outer diameter (hairspray might work as well). Pass the laser beam through the spinning disk at a radius that provides the least speckle in the reflected light distribution but retains a narrow enough beam to be useful. Choppers are available through optical supply companies. Note that this is not a shutter as would be used in a single-shot camera; a chopper and a shutter are different things.

**POLARIZERS:**

These are helpful in making diagnostics on the light detector's sensitivity to polarization. Several types are available from polarizing plastic sheet films to polarizer filters used with common cameras to high-quality prism polarizers. For most of the purposes of this document the inexpensive kind available at a camera shop will be adequate for diagnostics. If you get the plastic film type, be sure that they are not significantly colored like amber or brown. These are available from optical supply companies or camera stores.

**LASERS:**

The simple and readily available He-Ne red laser (632.8 nm) is a useful tool for aligning optical systems and devices and for diagnosing the temporal response of the light detector that is used in conjunction with a chopper. If the laser is to be used for light measurements in some way (e.g. BRDF measurements or temporal response measurements) it should be a stable laser, and these are considerably more costly than unstabilized lasers. The inexpensive He-Ne lasers are not usually very stable. Attention should also be paid to the polarization state of the laser beam if the laser will be used for measurements. It is best to get the randomly polarized lasers to avoid problems of polarization. The unpolarized laser beam can be polarized using an inexpensive polarizer from a camera shop. These are available through optical supply companies.

**LED & PULSE GENERATOR:**

A fast LED and a fast pulse generator that can create pulses with fast risetimes can be used to generate light pulses with fast risetimes to test the temporal response of an LMD like a photodiode or photomultiplier. LEDs are obtainable in a variety of colors, but be sure that the LED used is fast—high-speed LEDs are available with risetimes of 10 ns or less. How fast the LED needs to be depends upon the display technology. Pulse generators are available through electronics suppliers and equipment manufacturers. LEDs are commonly available from electronics parts suppliers.

**BLACK FELT:**

Black felt is a fabric that is usually blacker than most other flat-black paints and materials. It has a tendency to shed its fibers, however, so care must be exercised when using it around surfaces that need to be clean. This is available through optical supply companies or fabric companies.

**FLOCKED BLACK PAPER:**

Flocked black paper is blacker than most flat-black paints, but not as black as black felt. It has a surface that is somewhat like a fine-grained velvet. This is available through optical supply companies.

**BLACK TAPE:**

It is best to use the black masking tape rather than black electrician's tape because electrician's tape may be semitransparent to IR. Optical supply companies or art supply stores offer black masking tape.

**RESOLUTION TARGET:**

NIST 1010a and an Air Force resolution target can be useful for examining the effects of veiling glare for high-magnification optical systems and for determining the magnification of an imaging system (number of detector pixels per millimeter of the image). These are available through optical supply companies.

## A114 HARSH ENVIRONMENT TESTING

For testing of the display outside the default ranges of humidity, temperature, and pressure accommodated in this document it is left up to the user to determine if their measurement equipment is suitable for the harsh environments of interest. This section outlines some of the difficulties that may be anticipated in making these measurements. There are several configurations of the measurement equipment and the display that will be discussed. Goniometric measurements can be performed by moving the measurement equipment or moving the display. Usually, there is a chamber that provides the desired environment for testing the display. Probably the easiest way to see if the chamber has any effect on the measurements is to measure the display in a properly darkened room without the chamber, then re-measure the display in the chamber under similar conditions of temperature, humidity, and pressure as found in the room. Problems with reflections or measurements through any glass will be indicated and presumably correction may be made to the readings. This assumes that the display doesn't change its characteristics dramatically when under harsh environments; should the display change greatly, then the corrections obtained with and without the chamber may not be entirely appropriate. Here is where direct testing and characterization of the measurement system with and without the chamber would be required.

Should it be found that the reflections from the interior walls or glass window affect the measured results, steps can be taken to reduce the reflections. The user may wish to either coat the interior surfaces with a flat black paint (if this won't affect the performance of the environmental chamber) or hang black felt on the interior surfaces. The black felt is appealing since it is usually darker than flat black paint and it can be removed. These precautions may reduce the amount of reflections so they don't affect the measurements.

**ALL DEVICES IN THE CHAMBER:**

Both the measuring equipment and the display can be in an environmental chamber. In this situation, the measuring equipment needs to be able to perform within proper specifications for the range of environments that will be explored. If the measurement equipment changes its performance with a change in environments, then corrections must be made to the measurements accordingly. If the manufacturer doesn't supply such corrections (if needed), then the user will need to obtain them via experimentation and testing. An integrating-sphere light source and suitable paints may be useful for such testing, though the temperature may affect the performance of such sources. Glass filters must be used with caution since their transmission characteristics are usually sensitive to the absolute temperature. Fiber optic sources may be suitable for testing provided their transmission characteristics are either unaffected by or can be corrected for different temperatures.

**MEASUREMENT EQUIPMENT OUTSIDE THE CHAMBER:**

If measurements are made by equipment outside the chamber then there must be a window through which measurements will be made. Again, the best way to see how much the window affects the measurements is to make the same measurements on the display with and without the chamber (set at the same environment as the room).



Likely there will be a reduction of luminance because of the glass reflecting light back into the chamber, so a correction will be needed. There is also a possible effect from the polarization of the emitted light from the display interacting with the window differently than unpolarized light. A polarizer and a uniform light source can be used to diagnose polarization-induced luminance errors at various angles through the window (see Polarization Effects Diagnostics in this section for more information).

#### DISPLAY AND GONIOMETER IN CHAMBER:

The measuring equipment is outside the chamber, but the display and the goniometer are placed inside the chamber so that the display is rotated. If the display is rotated in the horizontal plane (about the vertical axis), there is generally no change in the display performance; but when the display is rotated in the vertical plane, the user must be sure that the display doesn't change its characteristics because of the change in direction of gravity relative to the display. Under extremes of temperature and under vacuum operation care should be exercised that the positioning equipment (goniometer) is suitable for that task.

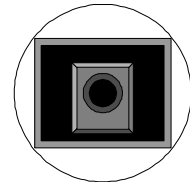
#### DISPLAY IN CHAMBER:

The display can be in an environmental chamber and the measuring equipment capable of making goniometric measurements are outside the chamber. For measurements made through the glass at an angle, there may be polarization effects encountered and reflection complications. By comparing measurements made with and without the chamber at the same conditions of humidity, temperature, and pressure, corrections should be able to be made for any anomalies.

## A115 ESTABLISHMENT OF PERPENDICULAR

### A115-1 Displays with Specular Reflection:

Some display surfaces have a regular specular component of reflection (mirror-like producing a distinct image). When this is the case, the image of the lens of the LMD can be seen in the surface of a black screen. If the reflection of the lens is difficult to see, you can put a polystyrene foam cup with its bottom cut out over the lens to make the lens more visible in the reflection. Be sure to focus on the image of the LMD and not the screen surface (for this setup only, generally we always focus on the screen). Alignments within better than  $0.1^\circ$  with the perpendicular of the screen are readily possible this way.



Visible virtual image of LMD centered in viewport of LMD

### A115-2 Mirror Held on Surface of Display

**DANGER:** *This method touches the screen. Be sure that the screen is capable of such rough handling before touching the surface.* A thin mirror placed against the face of the DUT will permit you to view the lens of the LMD in the display surface and adjust the rotation of the display until the image of the lens is centered in the viewfinder. Be careful no to damage the surface of the display in either holding the mirror against the surface or attaching it temporarily to the surface of the display. Some display surfaces are slightly flexible and a mirror will deform the surface making this method unsuitable.



### A115-3 Mechanical Alignment

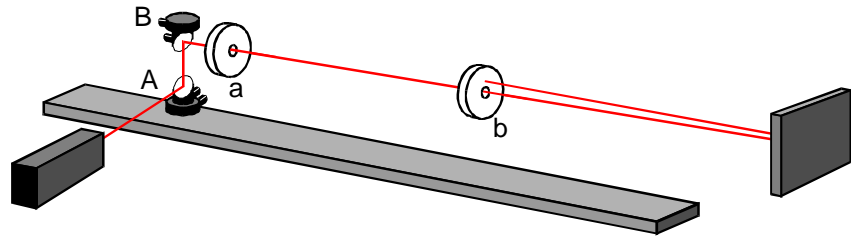
**DANGER:** *This method might touch the screen. Be sure that the screen is capable of such rough handling before touching the surface.* Here you use a good level to assure that the screen is vertical and that the optical bench is horizontal. If the screen will permit a level to touch its surface (and be otherwise handled) then you can place the level directly on the surface of the screen. If you can't touch the screen, you might be able to trust that the surface of any surrounding bezel is parallel with the surface of the screen, but that's a risky assumption. If the LMD is also level, then getting within  $0.3^\circ$  should be possible if you are careful.





## A115-4 Alignment with Optical Rail

If the LMD is on an optical rail that points toward the display, it may be important that the rail is perpendicular to the surface of the screen. Thus the LMD can be moved back and forth along the rail without changing the position of the observation spot



on the display. Such an alignment can be accomplished using a laser beam. An inexpensive He-Ne laser will do. Using a beam steering device, mirrors A & B (available from optics suppliers, mounting not shown), make the laser beam at the desired height of the LMD lens position. Make two targets with a small hole in their centers. Each target can be placed within a ring (not shown) mounted on a carriage (for the rail, not shown) and its position adjusted with screws. The position of the laser beam nearest the beam steering device (B) should be at the height of the target. Move the target (a) near the beam steering device and adjust the mirror nearest the laser (A) so that the laser beam goes through the hole in the first target (a). Adjust the second mirror (B) so that the beam goes through the second target (b). This can also be accomplished using one target. When the target is near the beam steering device adjust the mirror furthest from the target or nearest the laser (A). When the target is down the rail away from the beam steering device, adjust the mirror closest to the target or furthest from the laser (B). By going back and forth, the adjustment will converge on the laser beam being exactly at the level of the hole in the target and exactly parallel to the rail. This laser beam can now serve as a pointer to the center of the screen. The reflected laser beam, if there is a specular component of reflection, will now reflect back toward the rail. With the laser beam going through the target placed at the end of the rail nearest the display, the reflected beam will hit the front of the target (facing the display) as the display's normal approaches the direction of the laser beam. When the laser beam folds back on itself, then the display surface is exactly perpendicular to the rail (the laser beam is shown in the figure to fold back a little high above the hole for illustration purposes). The LMD can now be adjusted so that it looks parallel to the rail. Use a targets at close focus and at the end of the rail. Adjust the position and rotation of the LMD until the target can be moved up and down the rail and the LMD always focuses at the center of the target.

## A115-4 Rugged Displays Without Specular Reflections

**DANGER:** *This method touches the screen with objects and perhaps liquids. Be sure that the screen is capable of such rough handling before touching the surface.*

Displays that don't exhibit a regular (mirror-like producing a distinct image) specular reflection, yet are rugged enough to permit touching the surface can be temporarily modified to permit optical alignment. An alternative to using a mirror is to use a glossy plastic wrap material available in grocery stores. Such plastic may stick to the surface of the display sufficiently and threaten it the least. The reflection of the LMD lens may be observable by means of the gloss-plastic covering. You can place a small white target in front of the center of the lens or put a white shroud around the lens if it is difficult to see. If the surface is very rugged and can be washed with water, you can try some hair gel or glycerin between the clear plastic and the surface of the screen. Then smooth the surface with a flexible and soft squeegee (the free end of a pad of paper might work—without the cardboard). If that rugged surface of the screen is not very flexible, then a microscope slide or a cover glass might also be used with the gel to define a distinct-image specular surface. The gel or liquid used can be removed with water. When cleaning use distilled water if possible and a soft cloth or lens tissues. Paper towels, etc., can put small scratches in the surface of the screen—be careful. Again, use these methods *only* if the surface of the display is designed for such rough treatment.

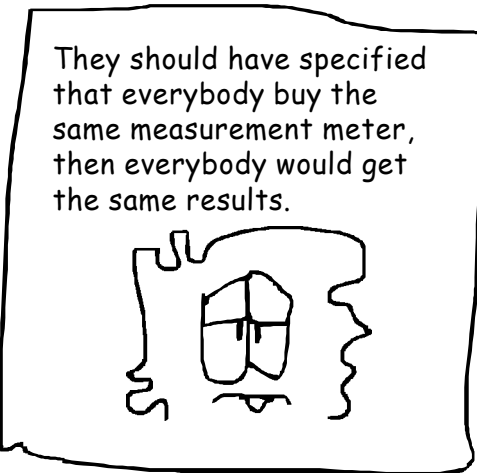
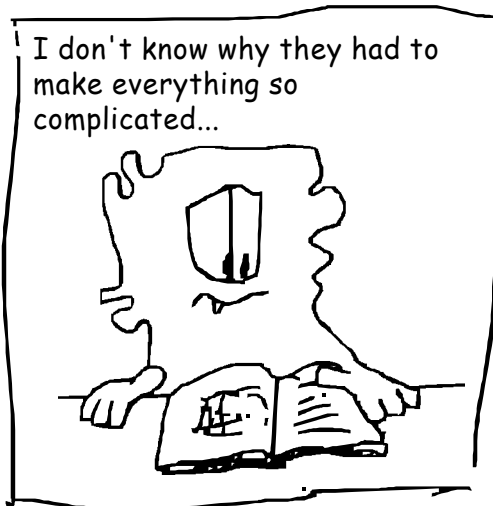
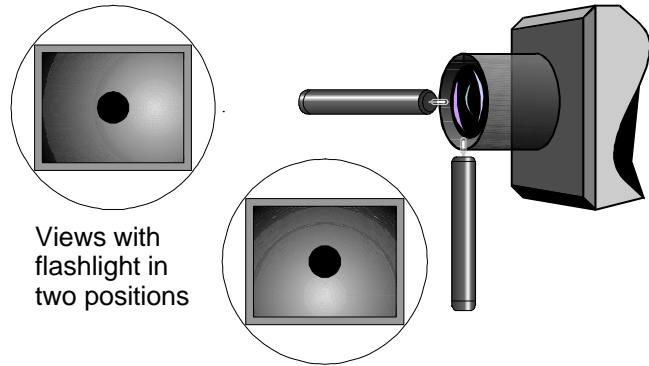




### A115-5 Fragile Displays Without Specular Reflections

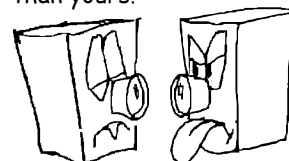
If there is not a regular specular component (mirror-like producing a distinct-image) of reflection from the display surface and if no part of the surface of the display can be touched in any way, then it is difficult to determine when the display is exactly perpendicular to the optical axis of the LMD. It may be possible to use crossed laser beams with a positioning system that has been carefully aligned with the optical axis of the LMD or the rail for the LMD. Intersect the laser beams at the center of the surface of the screen and make transverse excursions of the display using the positioner. When the laser beams remain intersected at a point for all excursions of the display surface, then the display surface is aligned properly.

If the display surface has a sufficiently peaked haze component of reflection (not creating a distinct image but obviously brighter in the specular direction), then it may be possible to see a fuzzy reflection of a polystyrene foam cup with its bottom cut out over the lens to make the lens more visible in the reflection. Another trick is to place a point light source like a bare flashlight bulb at the center of the LMD lens with a small opaque mask to prevent light going back into the lens. Then attempt to see the fuzzy spot on the reflection of the display and align the display so that the fuzzy spot is centered in the LMD viewfinder—centered over the measurement aperture. If the LMD is on a rail so that it can be moved closer to the display, and the LMD is aligned parallel with the rail, it may be easier to do this with the LMD and light closer to the display than it will be when the measurement is made. Alternatively, you might be able to place the bulb just directly below the lens of the LMD (or to the left) and align the fuzzy spot directly above (or to the right of) the bulb.



RUSTIC METROLOGY

My nit is bigger than yours!

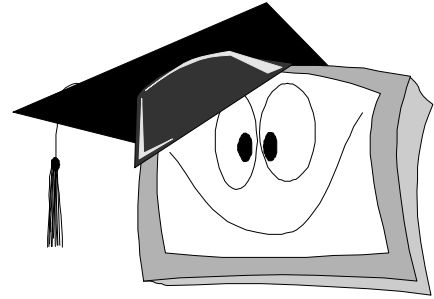




## A200 TECHNICAL DISCUSSIONS

This section is a catch-all section to provide various tutorials: photometry and colorimetry, some photometric calculations to help the reader gain familiarity with what most would consider to be as some very strange units (cd, lx, lm, etc.), and methods of optical analysis (OTF & MTF, etc.). It is our experience that many use photometry terms without really understanding them as fully as they would like. We hope this section helps.

There are a number of study problems presented here. These are intended to be examined with pencil in hand, working with the material as the description develops.



## A201 PHOTOMETRY AND COLORIMETRY SUMMARY

**Photometry** is the science of measuring visible light based upon the response of an average human observer. The primary unit of visible light power (**luminous flux**) used in photometry is the **lumen**. One watt of radiant flux at 555 nm is equivalent to a luminous flux of 683 lumens. Luminous flux (lumen) is defined as radiant flux weighted by the 1931 CIE Standard Observer function and can be calculated by the following formula

$$\text{Luminous flux in lumens } F = k \int_{360}^{830} S(\lambda)V(\lambda)d\lambda$$

where:

$S(\lambda)$  = Absolute spectral radiant flux in W/nm

$V(\lambda)$  = The spectral luminous efficiency for photopic vision. It is based on the 1931 CIE standard observer human vision model having the spectral responsivity of  $V(\lambda)$  for a field-of-view of  $2^\circ$ .

$k = 683[\text{lm/W}]$  = Conversion factor from watts to lumens at the peak of  $V(\lambda)$

$d\lambda$  = Data increment (nm)

As the equation shows, it is possible to measure light in the visible range with a filter/detector combination that matches the photopic function  $V(\lambda)$  and get photometric quantities. This is the basic principle of luminance meters. An alternate method, such as used with spectroradiometers, is to measure the spectral radiant flux and integrate the spectrum mathematically with  $V(\lambda)$  to obtain the photometric quantities. From this equation, you can get illuminance (lx) from  $S(\lambda)$  given as the spectral irradiance ( $\text{W m}^{-2} \text{nm}^{-1}$ ), and you can get luminance ( $\text{cd/m}^2$ ) from  $S(\lambda)$  given as the spectral radiance ( $\text{W sr}^{-1} \text{m}^{-2} \text{nm}^{-1}$ ).

There has been a tendency to associate the luminance with brightness, but this association is misleading. "Brightness" was at one time used as for luminance, but that is no longer the case. Brightness is the visual sensation of human eyes, and the eye's response to light is nonlinear (see Section A209), whereas luminance metric is linear (luminance meters have a linear response to light). More significantly, lights that are highly chromatic can appear brighter than white lights of the same luminance. The main experimental foundation of the  $V(\lambda)$  function (which was already standardized by the CIE in 1924) was not brightness matching but flicker sensitivity. The visual system is far less sensitive to temporally alternating lights when these lights have the same luminance. By alternating two monochromatic lights and varying the intensity of one of them, equal luminance is defined as the condition of least sensitivity to the flicker, i.e., lowest temporal frequency for which the visual system fails to see the flicker. It happens that spatial acuity and certain of its corollaries (such as legibility of print) are also determined principally by luminance (see P. Lennie, J. Pokorny, and V. C. Smith, *Luminance*, J. Opt. Soc. Am. A, Vol. 10 (1993), pp. 1283-1293). Given that the luminance predominates in determining sensitivity to flicker and to



spatial detail, luminance is almost certainly a basic visual channel, and luminance is an important aspect of light, quite apart from the colorimetric role of  $V(\lambda)$  described below.

### PHOTOMETRIC UNITS

Three of the most important terms used in photometry are luminance, illuminance and luminous intensity (see the following sections for more explanations). Although it would be logical to choose the lumen as the photometric base unit, the unit of luminous intensity, the candela, retains that role for reasons of tradition. The candela was defined as the luminous intensity of  $1/60$  of  $1 \text{ cm}^2$  of the projected area of a black body radiator operating at the temperature of the solidification of platinum (2045 K). This is no longer the definition. Since 1979 the candela is the luminous intensity, in a given direction, of a source that emits monochromatic radiation of frequency  $540 \times 10^{12} \text{ Hz}$  and that has a radiant intensity in that direction of  $(1/683) \text{ W sr}^{-1}$ . The candela is defined in terms of the lumen by:

$$1 \text{ candela} = 1 \text{ lumen per steradian}$$

The lumen is the luminous flux emitted per unit solid angle from an isotropic point source whose luminous intensity is 1 candela. Most lamps that are manufactured are rated in total lumen output. The solid angle is measured in steradians, and a steradian is the solid angle (cone) at the center of a sphere of radius  $r$  that subtends an area  $r^2$  on the surface of the sphere. Since the surface area of a sphere is  $4\pi r^2$ , the solid angle of a sphere is  $4\pi$  steradians.

**Luminance** is the most commonly measured photometric quantity and is required whenever it is necessary have some quantitative indication of how bright an object can appear to the eye. Luminance is defined as the luminous flux emitted from a surface per unit solid angle per unit area in a given direction and it is therefore the luminous intensity per unit area. The unit of luminance is the **candela per square meter ( $\text{cd}/\text{m}^2$ )** in SI (metric) units (this unit was at one time called a “nit” but that is considered improper currently—the nit is a deprecated unit) or the **footlambert (fL)** in English units.

$$\begin{aligned} 1 \text{ cd}/\text{m}^2 &= 1 \text{ lumen per steradian per square meter} \\ 1 \text{ fL} &= (1/\pi) \text{ lumens per steradian per square foot} \end{aligned}$$

The conversion factors are

$$\begin{aligned} 1 \text{ cd}/\text{m}^2 &= 0.2919 \text{ fL} \quad (\pi \text{ ft}^2/\text{m}^2 = 0.2918635) \\ 1 \text{ fL} &= 3.4263 \text{ cd}/\text{m}^2 \quad (\text{m}^2/\pi \text{ ft}^2 = 3.426259). \end{aligned}$$

**Illuminance** is the term used to measure the luminous flux incident on a surface per unit area and is given in lumens/square-meters ( $\text{lm}/\text{m}^2$ ). It is required when it is necessary to know how much light is falling on a surface, such as when illuminating a projection screen. The SI (metric) unit of illuminance is the **lux (lx)** or **footcandle (fc)** in English units.

$$\begin{aligned} 1 \text{ lux} &\equiv 1 \text{ lx} \equiv 1 \text{ lumen/ square meter} \\ 1 \text{ footcandle} &\equiv 1 \text{ fc} \equiv 1 \text{ lumen / square foot} \end{aligned}$$

The conversion factors are

$$\begin{aligned} 1 \text{ lx} &= 0.0929 \text{ fc} \quad (\text{ft}^2/\text{m}^2 = 0.09290304) \\ 1 \text{ fc} &= 10.76 \text{ lx} \quad (\text{m}^2/\text{ft}^2 = 10.76391) \end{aligned}$$

**Luminous intensity** (or “candlepower,” an obsolete word) is the luminous flux per unit solid angle emitted or reflected from a point. This is the quantity to describe the intensity of a light source in a specific direction. Since a point source is assumed, luminous intensity can be measured and used only at distances where the size of the source is negligible. LEDs are often characterized by luminous intensity and assumed to be point sources. The unit of luminous intensity is given in lumens/steradian ( $\text{lm}/\text{sr}$ ) and it is called the **candela**. Table 1 lists important radiometric quantities, units, and their photometric equivalents.



**Table 1.** Photometric and Radiometric Terms and Units  
sr = steradian, lm = lumen, W = watt, m = meter, cd = candela, fL = footlambert, fc = footcandle

Radiometric Term	Radiometric Unit	Photometric Term	SI Unit	English Unit
Radiant flux	watt (W)	Luminous flux	lumen (lm)	lumen (lm)
Radiant Intensity	watt/sr (W/sr)	Luminous intensity	candela (cd = lm/sr)	candela (cd = lm/sr)
Radiance	W/sr/m <sup>2</sup>	Luminance	cd/m <sup>2</sup>	footlambert (fL)
Irradiance	W/m <sup>2</sup>	Illuminance	lux (lx = lm/m <sup>2</sup> )	footcandle (fc)

**Perfect reflecting diffuser:** It is sometimes important to be able to transform illuminance as measured by an illuminance meter facing outward from a VDU screen into an equivalent screen luminance as measured by a luminance meter directed at a perfectly reflecting diffuser (Lambertian 100 % reflecting white surface) in the ambient light that was measured by the illuminance meter. If the screen were Lambertian with 100 % reflectance, and there were no absorbing faceplate, then there is a luminance equivalent to each illuminance unit (here, the symbol “↔” means “produces” or “is produced by”):

$$1 \text{ lx} \leftrightarrow (1/\pi) \text{ cd/m}^2 \quad (\text{for perfect Lambertian white surfaces only}).$$

The equivalent expression in English units avoid the 1/π factor—a simplification that encourages some to yet use the English units to this day—this is not recommended in this document.

$$1 \text{ fc} \leftrightarrow 1 \text{ fL} \quad (\text{for perfect Lambertian white surfaces only});$$

To avoid the 1/π factor, people (in the past) used a direct luminance equivalent of 1 lx called the apostilb, but this is not an SI unit, and should be avoided except for historical reasons. For further conversion factors and other units of light measurements, see [7] G. Wyszecki and W. S. Stiles, *Color Science* (Wiley, 1982), p. 251.

**Converting photometric units:** Suppose you need to have the luminance expressed in cd/m<sup>2</sup> but it is given to you in fL, you have the table below, but get confused as to how to use it. Here is a simple way: Multiply by one, where the denominator has the unit that you want to eliminate and the numerator has the unit you want to use. Thus, if you’re given a screen luminance as 37.5 fL and you want SI units...multiply by one...

$$37.5 \text{ fL} * 1 = 37.5 \text{ fL} * \frac{3.4263 \text{ cd/m}^2}{\text{fL}} = 128 \text{ cd/m}^2$$

Similarly, given an illuminance of 24.9 fc, what is the illuminance in lux? ... multiply by one...

$$24.9 \text{ fc} = 24.9 \text{ fc} * 1 = 24.9 * 10.76 \frac{\text{lx}}{\text{fc}} = 268 \text{ lx}.$$

SI (Metric) and English Photometric Conversion Table				
↓ = #### * →	cd/m <sup>2</sup> = lm/sr/m <sup>2</sup>	fL = lm/sr/ft <sup>2</sup>	lx = lm/m <sup>2</sup>	fc = lm/ft <sup>2</sup>
<b>1 cd/m<sup>2</sup> = 1 lm/sr/m<sup>2</sup></b>	1	0.2919		
<b>1 fL = 1 lm/sr/ft<sup>2</sup></b>	3.4263	1		
<b>1 lx = 1 lm/m<sup>2</sup></b>			1	0.09290
<b>1 fc = 1 lm/ft<sup>2</sup></b>			10.76	1
origin of number:	m <sup>2</sup> /π/ft <sup>2</sup> = 3.426259...	πft <sup>2</sup> /m <sup>2</sup> = 0.2918635...	m <sup>2</sup> /ft <sup>2</sup> = 10.76391...	ft <sup>2</sup> /m <sup>2</sup> = 0.09290304...
<b>1 = →</b>	3.4263 $\frac{\text{cd/m}^2}{\text{fL}}$	0.2919 $\frac{\text{fL}}{\text{cd/m}^2}$	10.76 $\frac{\text{lx}}{\text{fc}}$	0.09290 $\frac{\text{fc}}{\text{lx}}$

**COLORIMETRY**

Colorimetry is the scientific quantification and measurement of color. CIE Tristimulus colorimetry is the most common system used to quantify the color of displays, and it is based on the assumption that any color can be matched by a suitable combination of three primary colors ("stimuli")—generally red, green and blue. Once unit

DISCUSSIONS



quantities of three primaries have been defined, the gains on these quantities needed to match a given light are called that light's tristimulus values.

For any set of primaries in a matching experiment, the tristimulus values of monochromatic lights trace out three functions called the color-matching functions. From the observed linearity of human color matches, it follows that a change in primary lights is equivalent to a simple linear transformation of the color-matching functions for the first set of primaries. In 1931 the CIE standardized a single set of functions that no longer relied on which primaries were used in a particular matching experiment, but summarized many experiments. The tristimulus values of a light in this system are called  $X$ ,  $Y$ ,  $Z$ , computed as

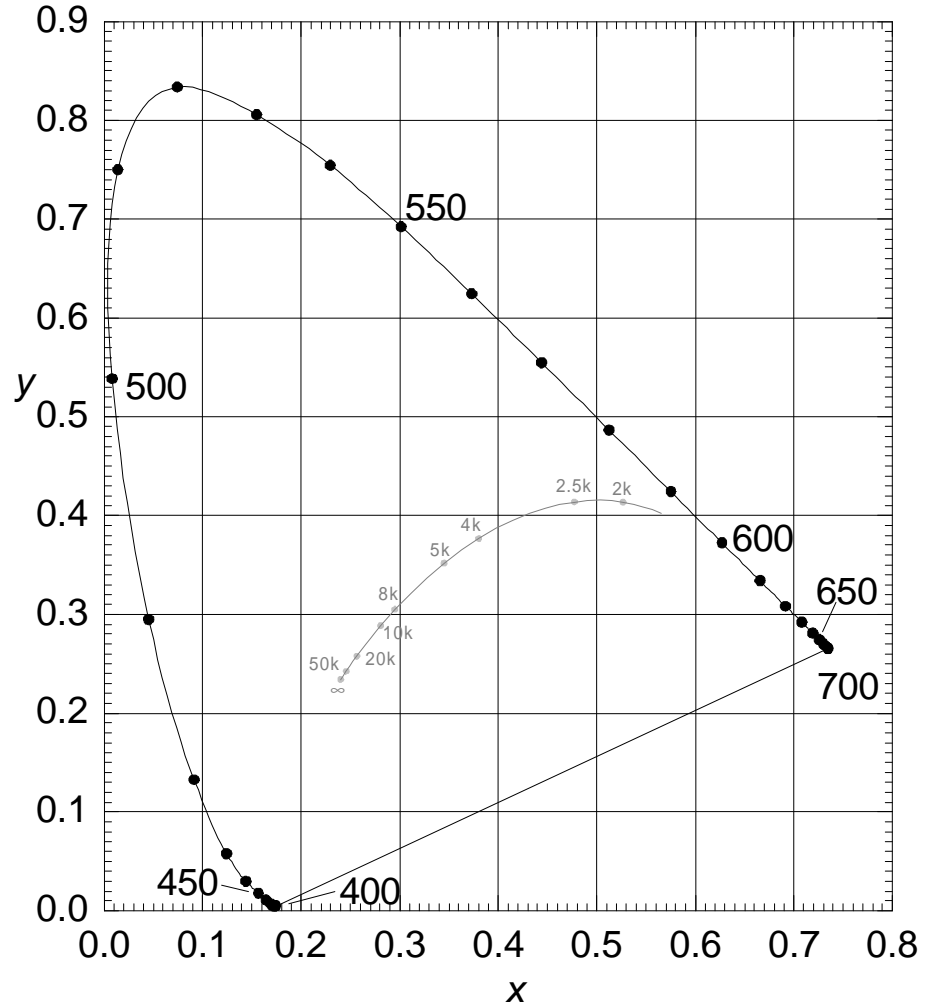
wavelength integrals of a spectral density of the light being measured  $S(\lambda)$  weighted by three visual sensitivities  $\bar{x}(\lambda)$ ,  $\bar{y}(\lambda)$ ,  $\bar{z}(\lambda)$  and multiplied by a constant  $k$ . The constant  $k$  can convert radiometric watts to lumens, or it can be used to normalize the tristimulus values to 100 with no units (some have normalized to one instead). See the table.

Any two lights that have the same values of  $X$ ,  $Y$ , and  $Z$  are defined to match (be the same color) according to the 1931 standard observer. Incidentally, the function  $\bar{y}(\lambda)$  is exactly equal to the function  $V(\lambda)$  defined in 1924 for photometry. [See the original CIE publication on color, CIE Publication No. 15.2, Colorimetry (1986). For further details on the history of the 1931 CIE system and how the previously defined photometric  $V(\lambda)$  was incorporated, see H. Fairman, M. Brill, & H. Hemmendinger, *Color Res. Appl.* 22 (1997), 11-23.]

Over the years the CIE standardized several color spaces derived from the 1931  $XYZ$  space, but in which equal distances in different parts of the space represented perceptual differences that were approximately equal. These were called uniform color spaces, and were especially useful in assessing color gamuts and the magnitudes of colorimetric errors.

Below is a summary of various CIE color spaces that have been used to evaluate displays. For detailed information including tables of color-matching functions, see [7] *Color Science: Concepts and Methods, Quantitative Data and Formulae*, Gunter Wyszecki and W.S. Stiles, 2nd Edition (1982, John Wiley & Sons) [7].

**1931  $x$ ,  $y$  - CIE Chromaticity Values.** These values are two-dimensional Cartesian coordinates that derive from  $X$ ,  $Y$ ,  $Z$  tristimulus values, in such a way that lights with the same relative spectrum but different intensities occupy the same  $(x, y)$  point. Hence the chromaticity values represent the colorimetric aspects of a light that are





independent of its intensity. The 1931 chromaticity values are designated as  $x, y, z$ , and they are the ratios of the tristimulus values  $X, Y$  and  $Z$  in relation to the sum of the three.

$$x = \frac{X}{X + Y + Z}$$

$$y = \frac{Y}{X + Y + Z}$$

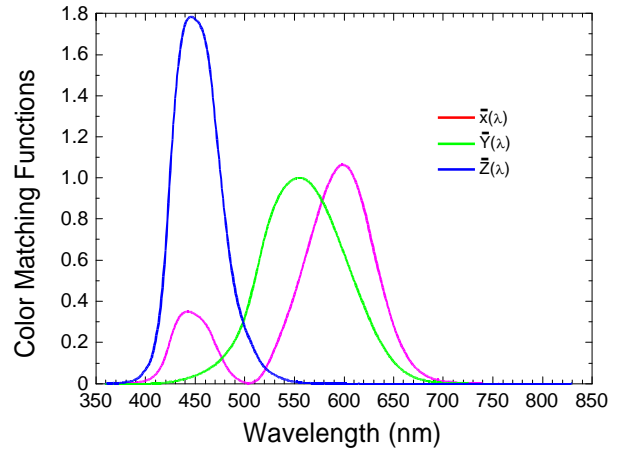
$$z = \frac{Z}{X + Y + Z}$$

$$x + y + z = 1$$

$$X = \frac{x}{y} Y$$

, or  $Y = \text{luminous flux}$

$$Z = \frac{z}{y} Y$$



Because  $z$  is redundant in chromaticity description, it is usually suppressed in favor of a two-dimensional plot of  $(x, y)$ .

In the CIE 1931 plot the curved line within the spectrum locus is the Planckian locus marked in temperatures of thousands of kelvins. The spectrum locus is labeled in increments of 50 nm. This is the color of white as the temperature of a (perfect) emitter is increased to an infinite temperature. This observation gives rise to the concept of color temperature as being a way to characterize the “level” of white.

<b>PHOTOMETRIC Y</b>	
(Only $Y$ is the photometric quantity.)	
$S(I)$ is illumination spectral density	
$Y = k \int_{360 \text{ nm}}^{830 \text{ nm}} S(I) \bar{y}(I) dI$ , where $k = 683 \text{ lm/W}$	
if $S(I)$ is in units of ...	then $Y$ is in units of ...
radiant flux (W/nm)	luminous flux (lm)
radiance (W/nm/sr/m <sup>2</sup> )	luminance (lm/sr/m <sup>2</sup> = cd/m <sup>2</sup> )
irradiance (W/nm/m <sup>2</sup> )	illuminance (lm/m <sup>2</sup> = lx)

<b>TRISTIMULUS VALUES</b>		
<i>General Case, Not Normalized</i>		
$S(I)$ is illumination relative spectral density in (nm) <sup>-1</sup> , $k$ is any convenient constant, e.g., $k = 1$		
$X = k \int_{360 \text{ nm}}^{830 \text{ nm}} S(I) \bar{x}(I) dI$ , $Y = k \int_{360 \text{ nm}}^{830 \text{ nm}} S(I) \bar{y}(I) dI$ , $Z = k \int_{360 \text{ nm}}^{830 \text{ nm}} S(I) \bar{z}(I) dI$ ,		
<b>NORMALIZED TRISTIMULUS VALUES —BASED ON WHITE POINTS</b>		
Normalization shown at 100, any other normalization constant may be used as desired.		
<i>For Reflection and Transmission:</i>		
$b(I)$ is relative reflection or transmission spectral density, $S(I)$ is illumination spectral density		
$X = k \int_{360 \text{ nm}}^{830 \text{ nm}} b(I) S(I) \bar{x}(I) dI$ , $Y = k \int_{360 \text{ nm}}^{830 \text{ nm}} b(I) S(I) \bar{y}(I) dI$ , $Z = k \int_{360 \text{ nm}}^{830 \text{ nm}} b(I) S(I) \bar{z}(I) dI$ ,		
$S(I)$ in any units (W/nm...?...)	No units for $X, Y, Z$ , maximum of 100 for $Y$	$k = 100 \left[ \int_{360 \text{ nm}}^{830 \text{ nm}} S(I) \bar{y}(I) dI \right]^{-1}$
<i>For Emissive Displays</i>		
$S(I)$ is spectral density of display white, $C(I)$ is spectral density of displayed color		
$X = k \int_{360 \text{ nm}}^{830 \text{ nm}} C(I) \bar{x}(I) dI$ , $Y = k \int_{360 \text{ nm}}^{830 \text{ nm}} C(I) \bar{y}(I) dI$ , $Z = k \int_{360 \text{ nm}}^{830 \text{ nm}} C(I) \bar{z}(I) dI$ ,		
$S(I)$ and $C(I)$ in any (but same) units (W/nm...?...)	No units for $X, Y, Z$ , maximum of 100 for $Y$	$k = 100 \left[ \int_{360 \text{ nm}}^{830 \text{ nm}} S(I) \bar{y}(I) dI \right]^{-1}$

DISCUSSIONS

**1960  $u, v$  — Uniform Chromaticity Scale (UCS).** An early uniform-color space, one of whose drawbacks was that it had only two dimensions. This space—a proper chromaticity space derived from linear combinations of  $X, Y, Z$ , is now used only for calculating correlated color temperature (CCT; see Glossary).

$$u = u' \text{ and } v = 2v'/3, \text{ where } u', v' \text{ are the 1976 UCS values below.}$$

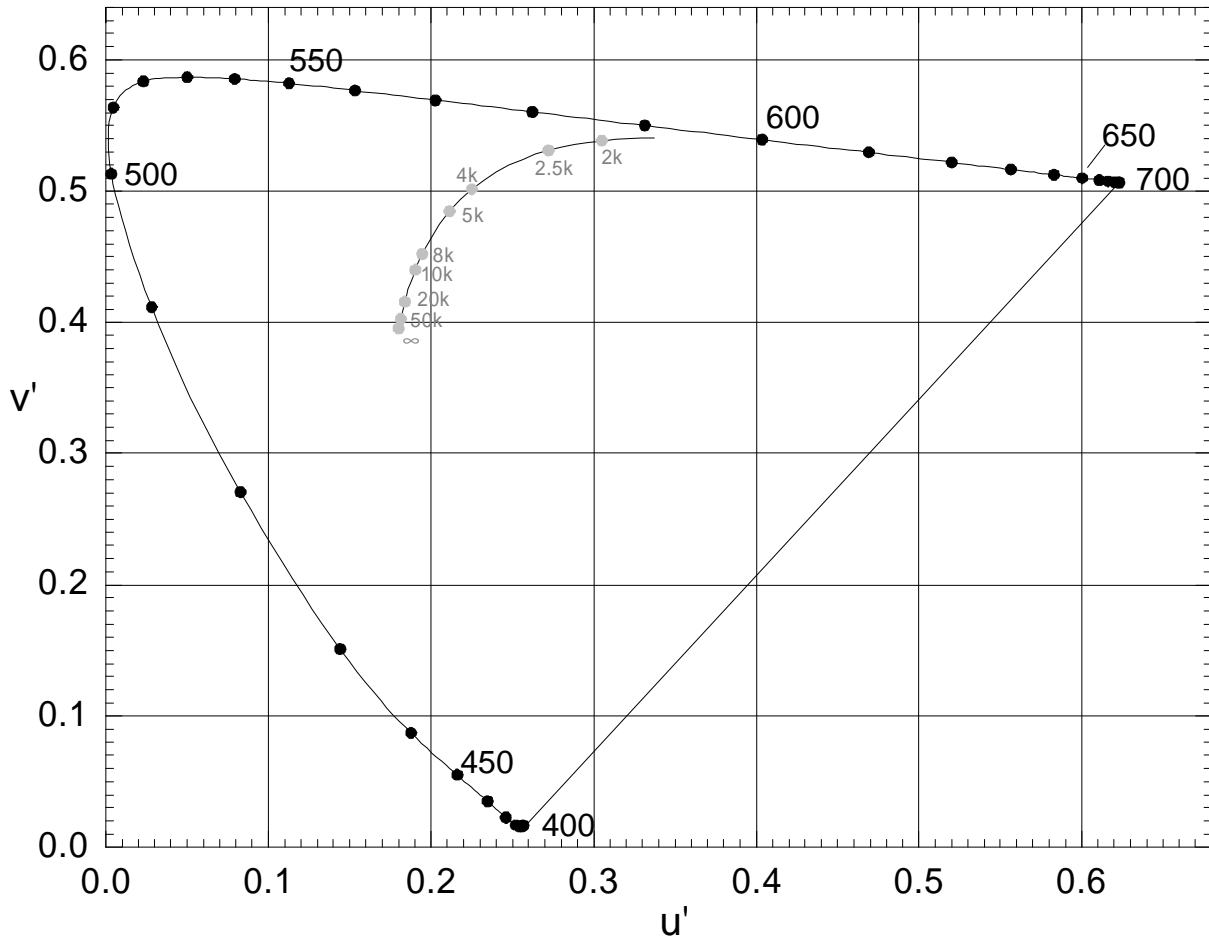
**1976  $u', v'$  — Uniform Chromaticity Scale (UCS).** Proper chromaticity space derived from linear combinations of  $X, Y, Z$ .  $\Delta u'v'$  is sometimes used as a color-shift metric when one wants to ignore intensity variations. In the plot the curved line within the spectrum locus is the Planckian locus marked in temperatures of thousands of kelvins. The spectrum locus is labeled in increments of 50 nm.

$$u' = \frac{4X}{X + 15Y + 3Z} \quad \left( = \frac{4x}{3 + 12y - 2x} \right) \quad x = \frac{27u'}{\frac{9u'}{2} - 12v' + 9}$$

$$v' = \frac{9Y}{X + 15Y + 3Z} \quad \left( = \frac{9y}{3 + 12y - 2x} \right) \quad y = \frac{3v'}{\frac{9u'}{2} - 12v' + 9}$$

$$\Delta u'v' = \sqrt{(u'_1 - u'_2)^2 + (v'_1 - v'_2)^2}$$

DISCUSSIONS





### CORRELATED COLOR TEMPERATURE (CCT).

Manufacturers and users often want a single-number summary of the color of a light source or of a display. Because many natural light sources resemble black-body radiators, a natural summary number is the temperature of the black-body radiator closest in color to the light source (or display) in question. Accordingly, correlated color temperature (CCT) is defined as the temperature (in kelvin) of the black-body radiator whose chromaticity is closest to the chromaticity of a particular light (e.g., from a display screen) as measured in the 1960 CIE ( $u$ ,  $v$ ) uniform chromaticity space. Despite the fact that the 1960 ( $u$ ,  $v$ ) space has been superseded by other uniform-color spaces (see below), the CCT continues to be defined in the earlier space, to afford consistency of description to light sources over time.

An algorithm for computing CCT, either from 1931 CIE ( $x$ ,  $y$ ) coordinates or from 1960 ( $u$ ,  $v$ ) coordinates, appears in [7] G. Wyszecki and W. S. Stiles, *Color Science*, Second Edition, Wiley, 1982, pp. 224-228, where graphical nomogram also appears. Alternatively, a successful numerical approximation has been derived by C. S. McCamy, *Color Res. Appl.* **17** (1992), pp. 142-144 (with erratum in *Color Res. Appl.* **18** [1993], p. 150). Given CIE 1931 coordinates ( $x$ ,  $y$ ), McCamy's approximation is

$$\text{CCT} = 437 n^3 + 3601 n^2 + 6831 n + 5517,$$

where

$$n = (x - 0.3320)/(0.1858 - y).$$

This approximation (the second of three he proposes) is close enough for any practical use between 2000 and 10,000 degrees Kelvin.

In units of 1960 ( $u$ ,  $v$ ) chromaticity, it is agreed that the concept of CCT has little meaning beyond a distance of 0.01 from the Planckian locus [see A. Robertson, *J. Opt. Soc. Am.* **58** (1968), 1528-1535], where the distance is specified by  $\Delta uv = \sqrt{(u_1 - u_2)^2 + (v_1 - v_2)^2}$ . However, industrial applications define CCT from 0.0175 ( $u$ ,  $v$ ) units above the Planckian locus to 0.014 ( $u$ ,  $v$ ) units below this locus.

Besides the unit of 1960 ( $u$ ,  $v$ ) distance, there is another unit commonly used to quantify distance of a given light from the black-body locus. This is the minimum perceptible color difference (MPCD), defined as a distance of 0.004 ( $u$ ,  $v$ ) units. The value 0.004 was introduced in the early days of color television to specify a minimum perceptible difference in ( $u$ ,  $v$ ) under not-too-critical conditions (see W.N. Sproson, *Colour Science in Television and Display Systems*, Adam-Hilger, 1983, page 42). This figure is often quoted in the lighting industry, and is now also applied to the distance metric in the ( $u'$ ,  $v'$ ) color space  $\Delta u'v' = \sqrt{(u'_1 - u'_2)^2 + (v'_1 - v'_2)^2}$  [see P. Alessi, *Color Res. Appl.* **19** (1994), 48-58]. A distance of 0.04 in ( $u'$ ,  $v'$ ) would be considered to be noticeable if the colors were separated such as each color being displayed on a different screen in different parts of the room, whereas the threshold distance 0.004 refers to two colored areas that are touching each other on the same screen.



**1976 CIELUV** — Currently standardized three-dimensional uniform-color space. Implicit in this space is a model of the nonlinearity of the eye, and also of chromatic adaptation to a light (typically D65 or the white point of the display) characterized by values with subscripts "w" below.

$$L^* = 116 \left( \frac{Y}{Y_w} \right)^{1/3} - 16, \quad \left[ \text{But } L^* = 903.3 \frac{Y}{Y_w}, \text{ for } \frac{Y}{Y_w} \leq 0.008856 \right]$$

$$u^* = 13L^*(u' - u'_w),$$

$$v^* = 13L^*(v' - v'_w).$$

$$\Delta E_{uv}^* = \sqrt{(\Delta L^*)^2 + (\Delta u^*)^2 + (\Delta v^*)^2}, \quad \Delta L^* = L_1^* - L_2^*, \quad \Delta u^* = u_1^* - u_2^*, \quad \Delta v^* = v_1^* - v_2^*$$

**1976 CIELAB** — Currently standardized three-dimensional uniform-color space. Implicit in this space is a model of the nonlinearity of the eye, and also of chromatic adaptation to a light (typically D65 or the white point of the display) characterized by values with subscripts "w" below.

$$L^* = 116 \left( \frac{Y}{Y_w} \right)^{1/3} - 16, \quad \left[ \text{But } L^* = 903.3 \frac{Y}{Y_w}, \text{ for } \frac{Y}{Y_w} \leq 0.008856 \right]$$

$$a^* = 500 \left[ \left( \frac{X}{X_w} \right)^{1/3} - \left( \frac{Y}{Y_w} \right)^{1/3} \right],$$

$$b^* = 200 \left[ \left( \frac{Y}{Y_w} \right)^{1/3} - \left( \frac{Z}{Z_w} \right)^{1/3} \right],$$

$$\Delta E_{ab}^* = \sqrt{(\Delta L^*)^2 + (\Delta a^*)^2 + (\Delta b^*)^2}, \text{ where } \Delta L^* = L_1^* - L_2^*, \quad \Delta a^* = a_1^* - a_2^*, \quad \Delta b^* = b_1^* - b_2^*$$

Modifications for low light levels :

For any tristimulus value  $W = X, Y, Z$ , in the above expressions for  $a^*$ ,  $b^*$ ,

$$\text{replace } \left( \frac{W}{W_w} \right)^{1/3} \text{ with } \left( 7.787 \frac{W}{W_w} + \frac{16}{116} \right) \text{ whenever } \frac{W}{W_w} \leq 0.008856.$$

Both CIELAB and CIELUV color spaces were simultaneously adopted and thereafter retained as equally preferred standards by the CIE [see CIE Publication 15.2, Colorimetry, First Edition (CIE, 1976) and Second Edition (CIE, 1986)]. However, display technologists have historically preferred CIELUV. This preference is based on the fact that CIELUV has a proper chromaticity space (with coordinates  $u^*/L^*$ ,  $v^*/L^*$ ), in which any additive mixture of two lights shows up on the line segment between them in this space. This feature, which is not shared by CIELAB, offers a convenient portrayal of composition of color in additive systems such as self-luminous displays. Admittedly, the CIELAB space has been recently selected by some display technologists as being more nearly uniform with respect to small color differences. However, the uniformity of these spaces is still open to question based on primary data, and CIELUV remains attractive because of its convenience and historical precedent. The present document does not recommend CIELUV as being ultimately preferable to CIELAB or to other color-difference formulas, but uses CIELUV in sample calculations as a color space sufficient for the measurements at hand.

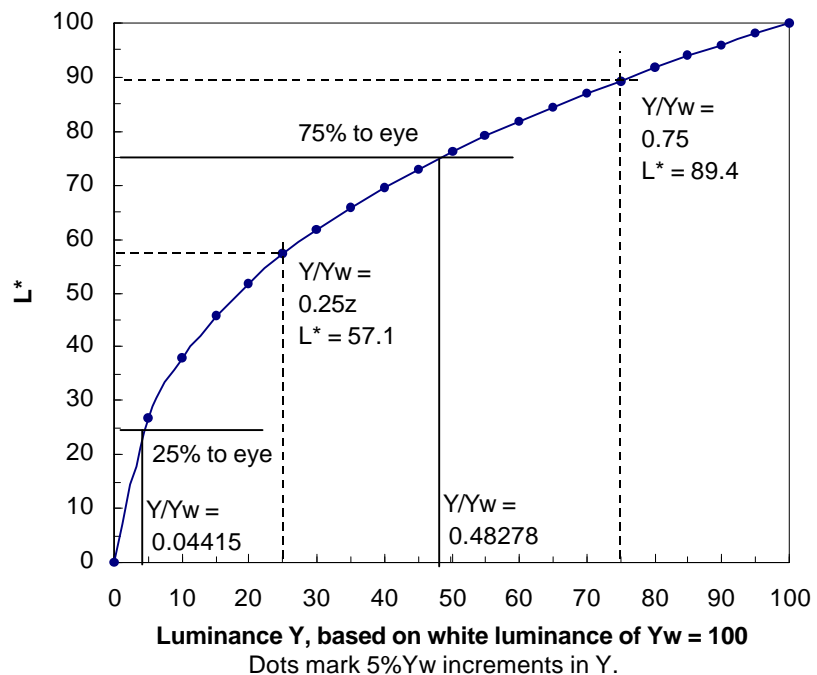
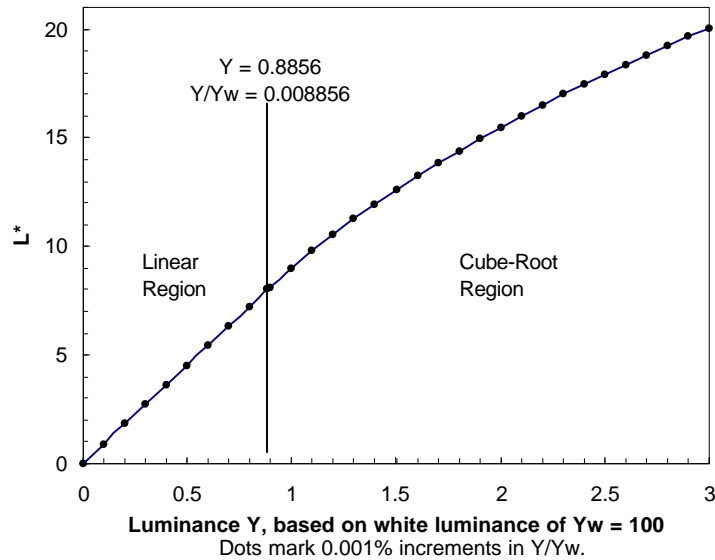
A note is due about the uses and perceptual interpretations of  $\Delta E$  and  $\Delta u'v'$ . The quantity  $\Delta E$  is intended as a measure of the number of just-noticeable differences (JNDs; see Glossary) between two displayed colors with given tristimulus values. The fact that  $\Delta E$  is a Euclidean metric in a given color space (CIELAB or CIELUV) indicates a model of color perception in which CIELAB or CIELUV distance—perceptual magnitude—is measured in units of JNDs. Despite the fact that the discriminability of two colors depends on viewing conditions, and the experimental basis of CIELAB or CIELUV uses special viewing conditions (see Wyszecki and Stiles, 1982),  $\Delta E$  is interpreted as a general-purpose color metric. In display technology, we find  $\Delta E$  used, e.g., to quantify dependencies of color on screen position and viewing direction. However,  $\Delta E$  is not used to describe the distance between two colors that arise on displays with different white points. It is tacitly specified that the same ( $X_n$ ,  $Y_n$ ,



$Z_n$ ) triplet (nominally the same observer adaptation state) be used for each color in a comparison yielding a  $\Delta E$  value.

The quantity  $\Delta u'v'$  does not have such a ready perceptual interpretation as  $\Delta E$ , but is useful when one wants to set independent tolerances on luminance and chromaticity. A color shift of  $\Delta u'v' = 0.004$  will be discernable if the two color patches are touching, and a color shift of  $\Delta u'v' = 0.04$  will be discernable on two separate displays. Suppose, for example, that the luminance uniformity on a screen is subjected to a fairly loose tolerance (because human vision is insensitive to luminance variations with low spatial frequencies). If a tight chromatic tolerance is set with respect to  $u^*$  and  $v^*$  (to reflect high sensitivity to chroma variations at low spatial frequencies), then that tolerance will be driven by luminance variations for any chromaticities but that of the white point. This will impose de facto a tight tolerance on luminance uniformity. However, if a tight chromatic tolerance is set with respect to  $u'$  and  $v'$  (as it is with  $\Delta u'v'$ ), the sensitivity of vision to isoluminous color variations at low spatial frequencies is accommodated without imposing a needless restriction on the luminance uniformity.

A comment is in order about  $L^*$ , which is the same in both CIELUV and CIELAB. In the figures to the right we show how  $L^*$  depends upon the ratio of the luminance  $Y$  to the luminance of white  $Y_w$ . The linear portion (from  $Y/Y_w = 0$  to  $Y/Y_w = 0.008856$ ) smoothly matches the cube-root portion (the first derivative is continuous across  $Y/Y_w = 0.008856$ ). The top figure shows the region about the linear portion. The bottom figure shows the entire range of  $Y/Y_w \leq 1$ . See Section A209 (Nonlinear Response of the Eye) for a discussion of the bottom figure.



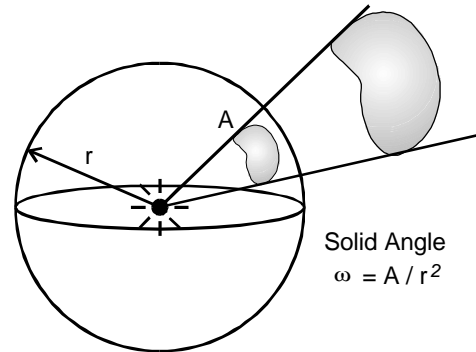
DISCUSSIONS



## A202 POINT SOURCE, CANDELA, SOLID ANGLE, $I(q, f)$ , $E(r)$

**Abstract:** We look at a point source of light which naturally gives rise to the concept of solid angle whereby we can see the reasonability of the candela as a unit of light measurement. Luminous intensity  $I$  and illuminance  $E$  are also defined and considered.

Consider a point source of light that emits rays of light or light energy uniformly in all directions. Consider a small area  $A$  of a sphere of radius  $r$  that is centered on the point source of light. Since light travels in straight lines (rays), the bundle of rays going through the area  $A$  will, in effect, project that area onto larger diameter spheres. This cone that is centered at the point source and subtends the area  $A$  will always contain the same rays of light no matter how far away we are from the point source. We want a metric to specify how much of a spread this cone constitutes. The metric to use is the **solid angle** which is the ratio of the spherical area  $A$  to the square of the radius  $w = A/r^2$ . The solid angle is manifestly unitless, but it is given a unit: the steradian with abbreviation sr. We speak of solid angles in steradians; for example, the solid angle of a sphere is  $4\pi$  sr.



Should this be an uncomfortable definition for the first time reader, note that it is very similar to radian measure of an arc, we might think of it as a three-dimensional angle. In a plane, an arc of length  $l$  at radius  $r$  along a circle is subtended by an angle  $q = l/r$ , where  $q$  is in radians, abbreviated rad. An entire circle has a radian measure of  $q = 2\pi$ . Often the unit rad is left off, it is understood to be there, we could have said  $q = 2\pi$  rad as well. By the way, to convert to degrees we use:  $q$  [in degrees] =  $360^\circ q / 2\pi$ . Extending this to three dimensions by similarity, we express the solid angle as  $\omega = A/r^2$ , which is a measure of the subtense of a spherical area from a point in space just as we express the angle as  $q = l/r$  which is a measure of the subtense of a circular arc from a point in space. The solid angle is the three-dimensional angular cone that subtends a spherical area  $A$  just as the angle (in radians) is a (two-dimensional) angle that subtends a circular arc length.

Note that the area  $A$  used in the solid-angle determination is the area on the surface of a *sphere* not a planar area. However, for radial distances large compared to the maximum linear width of a planar area, the planar area can be used with little error. What is the difference between the area of a disk and the area of a spherical cap of the same diameter? Consider a sphere of radius  $r$  centered in a spherical coordinate system, and a spherical cap centered on the polar axis. Suppose  $q$  is the angle subtended between the polar axis and the outside diameter of the cap. The area of the spherical cap can be shown to be  $A = 2\pi r^2(1 - \cos q)$ . Associated with this cap is a planar disk defined by the diameter of the spherical cap. The radius of this disk is  $x = r \sin q$ , and its area is  $S = \pi r^2 \sin^2 q$ . For small angles such that  $\sin q = q$  is an acceptable approximation, these two areas are the same (expand the cosine). (See A214 and compare with A215 and A225.)

How do we specify the intensity of the point source? One way is the amount of **luminous flux**  $F$  (measured in lumens, lm) emanating from the point. This is a measure of the amount of light coming from the point source in all directions combined. Luminous flux is kind of like a “visible light watt,” it is proportional to the visible power of the emitted light. Another way to express the amount of light from the point source is by taking the ratio of the luminous flux  $F_A$  (in lm) that hits area  $A$  and the solid angle  $w = A/r^2$  (in sr). This ratio is called the **luminous intensity**  $I = F_A/w = F_A r^2/A$ , and has units of lm/sr which is called a candela with symbol cd. In general, the luminous intensity is a function of the direction of emission  $I = I(q, f)$ , but for our purposes in this problem, it is a constant. For our uniformly emitting point source what is the luminous intensity? Divide the total luminous flux  $F$  by the solid angle of a sphere:  $I = F/4\pi = \text{constant}$  (units are lm/sr = cd). Now, let’s think about the light hitting area  $A$ . The luminous flux hitting  $A$  (number of lumens hitting  $A$ ) is  $F_A = Iw$ . That flux is spread uniformly over the entire area  $A$ . This raises the need for another convenient metric of light, the **illuminance**  $E$  which is the number of lumens per unit area hitting  $A$ ; it has units of lm/m<sup>2</sup> which is called a lux, the unit’s symbol is lx. In our case here, the illuminance is the quotient of the luminous flux hitting  $A$  and the area:  $E = F_A/A = Iw/A = I/r^2$  [lm/m<sup>2</sup>]. (Although the luminous intensity has units of lm/sr, we often write equations like this where we have canceled out the steradians but only keep track of that in our minds. To indicate the correct units or remind the reader of the correct units often one will find the units expressed in brackets after the equation to be sure to be



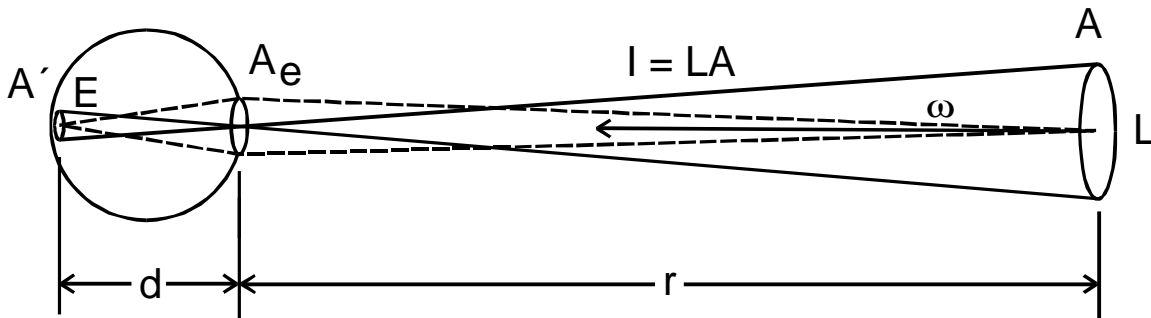
clear. Some people deliberately add a quantity  $W_0 = 1$  sr to the equations in order to keep track of the steradians. In such a case  $I = F/4\pi W_0$ ,  $W = W_0 A/r^2$ ,  $E = W_0 I/r^2$ , etc.) Things like luminous intensity, candelas, illuminance, and the like can be very confusion for the novice (even for the not-so-novice). One of the best ways to help to remove the confusion is to be able to express units of light measurement in their most fundamental units,  $\text{lx} = \text{lm}/\text{m}^2$ ,  $\text{cd} = \text{lm}/\text{sr}$ , etc., and carefully keep track of these fundamental units as these quantities are used in equations. Thinking in terms of the units as well as the names of these quantities should make things easier.

**PROBLEM:** Suppose we are given the luminous flux  $F = 10,000$  lm of a point source that emits light uniformly in all directions, and we have a card of area  $A = 0.01$  m<sup>2</sup> (100 mm x 100 mm) placed a distance  $d = 0.5$  m away from the point source; what is the luminous intensity of the point source, the illuminance on the card, and the luminous flux on the card?

Provided  $d$  is large compared with the size of the card (and it is in this example), we can assume that the area  $A$  is the same as the area of the card projected on a sphere of radius  $d$  and use the formalism derived above. (Otherwise we would have to use calculus to perform the integration over the area  $A$  and this we will do in another problem below.) The solid angle of the card is  $w = A/d^2 = 0.040$  sr. The luminous intensity of the point source is  $I = F/4\pi = 795.8$  cd [lm/sr]. The luminous flux (number of lumens)  $F_A$  on  $A$  is  $F_A = Iw = 31.83$  lm, whereby the illuminance on area  $A$  is  $E = F_A/A = Iw/A = I/d^2 = 3183$  lx [lm/m<sup>2</sup>]. Notice that this is exactly the same as the luminous flux  $F$  times the fraction that the area  $A$  is of the radius of a sphere of diameter  $d$ :  $F_A = F(A/4\pi d^2)$  which is what we get if we do all the algebra:  $F_A = EA = (I/r^2)A = (F/4\pi r^2)A = FA/4\pi r^2$  using  $r = d$ .

**A203 LUMINANCE -  $L(z)$  FOR DIFFUSE OBJECT**

**Abstract:** The luminance of an object is a type of objective measure of brightness (a subjective quantity). It has units of  $\text{cd}/\text{m}^2$ . **Problem:** Calculate the luminance as a function of position as we move away from a uniformly illuminated wall, and show that the luminance of an object is independent of distance.



We can consider a number  $n$  of point sources each having luminous intensity  $I_k$  in candelas ( $\text{cd} = \text{lm}/\text{sr}$ ) distributed evenly throughout an area  $A$ . Assume that there are so many of them that we can't resolve the individual illuminants with our eyes so that the surface appears uniform. The total luminous intensity from the area  $A$  is

$$I = \sum_{k=1}^n I_k \tag{1}$$

The more point sources we cram into that area the brighter that area will appear to our eyes. The number of these sources (how many candelas) per unit area is called the **luminance** and has units  $\text{cd}/\text{m}^2 = \text{lm sr}^{-1} \text{m}^{-2}$ . This unit was at one time called a nit, but that usage is no longer considered proper—the nit is a deprecated unit. (Isn't that great?! So instead of saying a one syllable "nit" we have to say a mouthful, the seven syllable phrase "candelas per meter squared.") Avoid using brightness when you mean luminance. Luminance is a unit of measure, a quantitative value. Brightness is subjective. Under the same illuminance, luminance on black paper is low and that on white paper is high. However, something that may be considered bright at night may be perceived as dim during the day (e.g., the moon). Consider a source with constant luminance, the perception of luminance—which we may very roughly call brightness—changes depending upon the ambient conditions, whereas the luminance of that source remains the same (assuming the environment doesn't affect the light output of the source).

DISCUSSIONS



Another way to define luminance is by using infinitesimals. Consider a small area  $dA$  that emits light with luminous intensity  $dI$ . The ratio of the luminous intensity to the area is defined as the luminance:

$$L = dI/dA. \quad (2)$$

This means that when we are talking about small areas that are far away from the observation point ( $A \ll r^2$ ) then we can say to a good approximation

$$L = \frac{I}{A}, \text{ or } I = LA \quad (\text{long distance approximation}). \quad (3)$$

These relations will be found to be useful in the rest of these problems. Now, let's consider what the eye sees; how does the luminance of an object change with distance?

Imagine looking at the area  $A$  (such as described above) having a luminance of  $L$  with the eye at a distance  $r$  from the area, where  $r$  is much larger than the size of the area viewed  $r \gg A$ . The lens of the eye focuses that area down to an area  $A'$  on the retina of the eye. Let's assume that the illuminance on the retina for this configuration is  $E$ . The size of the area on the retina depends upon the distance from the source. Let  $A_e$  be the aperture area of the eye, and suppose the distance from the center of the lens of the eye to the retina is  $d$ . How much light enters the eye? The luminous intensity from the area  $A$  is simply  $I = LA$  for long distances. Then the light entering the eye (the luminous flux) is  $F = Iw$ , where  $w$  is the solid angle of the aperture of the eye,  $w = A_e/r^2$ , or  $F = LAA_e/r^2$ . That light is spread over the image  $A'$  so that the illuminance on the retina is  $E = F/A'$ . From simple geometry consideration, the size of the area of the image is proportional to the square of the distances involved:  $A' = Ad^2/r^2$ . It is the illuminance on the retina that we want to determine, i.e., the lumens per unit area; it is this illuminance that gives the perception of brightness. Putting these equations together we find  $E = LA_e/d^2$ , which is independent of distance  $r$  that the eye is from the area. We could have simply reasoned this way: The image size at the retina goes as  $1/r^2$ , but the amount of light entering the eye goes down as  $1/r^2$ . The ratio of the two remains a constant, thus the luminance is independent of distance.

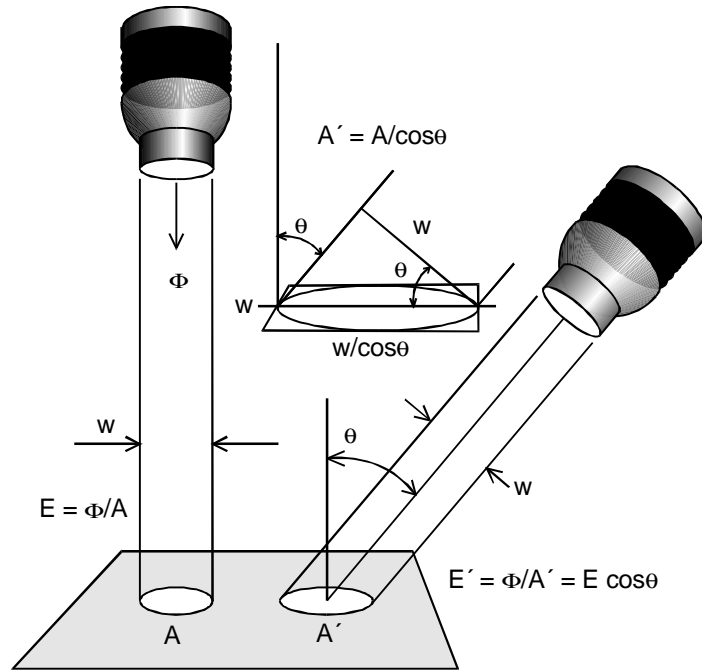
(NOTE: Many refer to luminance as the objective measure of subjective brightness. While this may be true when comparing the same colors, it is not true in general, and it is easy to see. Place three bars of primary colors on the screen of a display—e.g. RGB—and adjust the brightness of the bars so that they appear to have the same brightness to the eye. The luminances will not be the same. The blue and red will have larger luminances than the green. Now, put an identical word with black letters in each of the color bars and adjust the brightness of the bars so that the words are about as readable in each color—you might have to step back from the screen so they will be a little fuzzy. When you measure the luminance now, you will find it to be more nearly the same for each color. See A201.)



**A204 SPOTLIGHT VS. ANGLE -  $\cos(\theta)$**

**Problem:** Show that when a spotlight hits a surface the illuminance upon the surface changes as  $\cos q$  where  $q$  is the angle of the source from the perpendicular of the surface for a distant source like a spotlight (or the setting sun if you are on the moon).

Consider a spotlight having a uniform parallel beam of width  $w$ , cross-section area  $A$ , and luminous flux  $F$  in lumens (lm). The illuminance upon a surface when the beam is perpendicular to that surface is  $E = F/A$  (in lx = lm/m<sup>2</sup>). If the direction of the spotlight is changed to an angle  $q$  from the perpendicular, then the area of the surface  $A'$  illuminated becomes more elongated as the angle increases (that area becomes infinite when the beam lies in the plane of the surface,  $q = 90^\circ$ ). The dimension of the beam orthogonal to the plane of the angle and the perpendicular is still  $w$ , but the dimension of the beam in the plane of the angle becomes  $w/\cos q$ , see the figure. The areas are related by  $A' = A/\cos q$ . The same amount of light (luminous flux)  $F$  is being spread over a larger area, so that the illuminance becomes less:  $E' = F/A' = E \cos q$ . Thus, the illuminance from a beam of light falls off as the cosine of the angle from the normal.



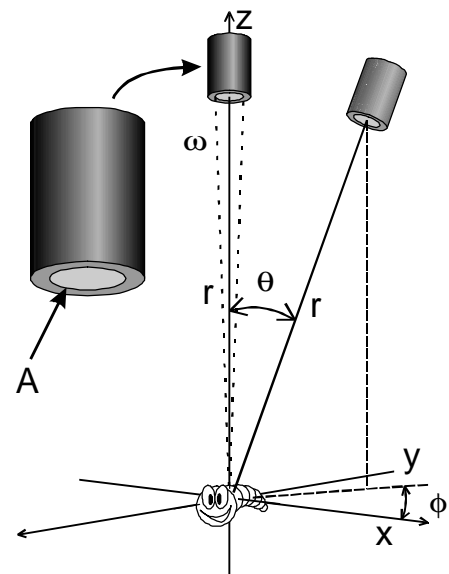
**A205 GLOWWORM & DETECTOR,  $I(q, f)$ ,  $J=kF$**

**Problem:** Given a nonuniform source producing a luminous intensity that is a function of position around the source (a glowworm, for example)  $I(q, f)$  write an expression for the total light output and the current output from a detector with a sensitivity of  $k$  in A/lm placed a radius of  $r$  from the source. Suppose the maximum luminous intensity of  $I_0 = 100$  cd occurs directly above the source, what is the maximum current obtained from the detector assuming a sensitivity of  $k = 1.2$  A/lm with the detector at a distance of  $r = 0.95$  m and having a detection surface of area  $A = 1.1$  cm<sup>2</sup> (cm<sup>2</sup> not m<sup>2</sup>).

Suppose that the glowworm produces light in all directions. That light can be described by the luminous intensity as a function of orientation around the source or glowworm  $I(q, f)$ . The total light output (total luminous flux) is the integration of the luminous intensity over the spherical solid angle

$$F_T = \iint I(q, f) \sin q \, dq \, df, \tag{1}$$

but without knowing the exact form of  $I$ , we cannot perform the integration, of course. Here,  $dw = \sin q \, dq \, df$  is the element of solid angle in spherical coordinates. The amount of light entering the detector depends upon the area of the detector  $A$  and its distance from the source  $r$ . We will assume that the detector is always oriented so that it is facing the source. If the detector were not facing the source, then we would have to correct for the misalignment by a cosine factor  $\cos b$ ,



DISCUSSIONS



where  $b$  is the angle between the axis of the detector (normal to the detector's surface) and the radius vector locating the position of the center of the detector. For this problem we will assume that  $b = 0$ , i.e., the detector is always facing the source. The solid angle of the detector from the position of the source is  $w = A/r^2$ . The luminous flux entering the detector is simply

$$F(q, f) = Iw = I(q, f)A/r^2. \quad (2)$$

This light is converted to current  $J$  by the detector according to the relation  $J = kF$ . Putting this altogether, the current output of the detector is

$$J(q, f) = kF(q, f) = kI(q, f)A/r^2, \quad (3)$$

where  $J$  is in amps and  $k$  is in amps per lumen (A/lm). Thus, at the  $q = 0$  position where  $I(0,0) = I_0 = 100$  cd, given that  $k = 1.2$  A/lm, the luminous flux entering the detector of area  $A = 1.1 \text{ cm}^2 (= 0.00011 \text{ m}^2)$  at  $r = 0.95$  m, is  $F = I_0 A/r^2 = 0.0122$  lm. The output of the detector would then be  $J = kF = 14.6$  mA.

## A206 PROPERTIES OF A LAMBERTIAN SURFACE

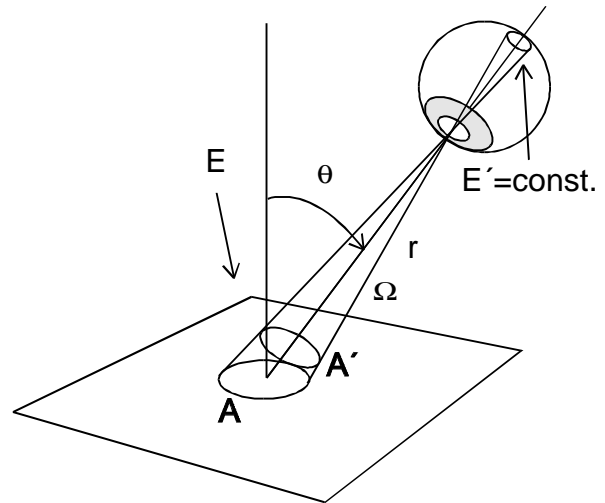
**Abstract:** A perfectly diffuse surface appears to have the same luminance when viewed from any direction. Such a surface is defined as a Lambertian surface. The luminous intensity from a small area  $A$  is derived to be  $I = I_0 \cos q$  where  $q$  is the angle from the perpendicular (or normal) of the surface and  $I_0$  is the luminous intensity in the perpendicular direction. Also, given that the surface reflectance is  $r$ , we show that the luminance of a Lambertian surface is related to its illuminance by  $L = r E/\pi$ .

A Lambertian surface is one that will appear to have the same luminance to the eye no matter from what angle the surface is observed. Many surfaces are quasi-Lambertian, flat (matte) paint, copy paper, etc. Consider looking at a small area on the extended surface. A simple way to obtain the desired result is to note that if the surface has the same brightness to the eye (or luminance) for any angle, then as our observation angle from the normal increases we are looking at an extended area within the same solid angle of view; and that area increases by  $1/\cos q$ . If the luminance is the same for any angle, as the observed area increases with larger angle from the perpendicular, the luminous intensity must decrease by  $\cos q$  or  $I = I_0 \cos q$ , where  $I_0$  is the perpendicular value.

If that is confusing, let's look at it in greater detail. Refer to the figure. For the view to remain the same really means that the area viewed by the eye is such that the solid angle it subtends remains constant. That is, if we say the eye sees the same something in all directions, we generally mean that the eye evaluates that something over a fixed solid angle. Thus  $W = \text{constant} = A'/r^2$ . Here  $A'$  is the area perpendicular to the viewing direction (the apparent area) at angle  $q$  and is related to actual area viewed on the surface via  $A = A' \cos q$ . That is, when  $q = 0$ , the perpendicular direction, the area of the surface  $A$  is the same as the apparent area  $A'$ . The luminance is related to the luminous intensity by  $I = LA$ , or, since the luminance is constant  $L = I/A = \text{constant}$ . (See A203 for long distances or small solid angles.) Solving for the luminous intensity and expressing the area  $A$  in terms of the constant area  $A'$  we obtain  $I = LA = LA' \cos q$ . However, note that the quantity  $LA'$  is the luminous intensity for  $q = 0$ , or  $I_0 = LA'$ . Putting this together, we have the classic expression for the luminous intensity for a Lambertian emitter in terms of the luminous intensity normal to the surface  $I_0$

$$I = I_0 \cos q, \quad [\text{LAMBERTIAN}]. \quad (1)$$

We can now define **luminance** another way: luminance  $L$  is the luminous intensity  $I$  from a surface element  $dA$  in a given direction, per unit area of the element projected on a plane perpendicular to that given direction as given by  $L = I/(dA \cos q)$  where  $q$  is the angle of the viewing direction. The  $\cos q$  means that when you view the same surface element at an angle  $q$ , its area looks smaller by a factor of  $\cos q$ . Assuming that the surface is uniform, the





luminous intensity  $I$  increases proportionally as  $dA$  increases, but the luminance  $L$  is constant and independent of  $dA$ . Also, if the surface is Lambertian, the luminous intensity  $I$  decreases by a factor of  $\cos q$  as the viewing angle increases, but the luminance  $L$  is constant and independent of the viewing angle.

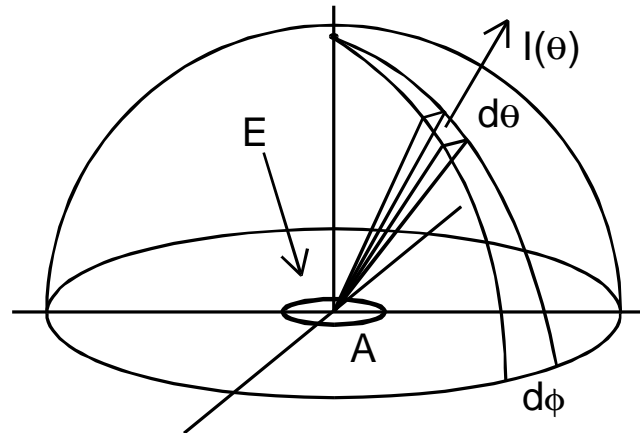
**Reflection:** Now, consider a reflecting surface (not an emitting surface) having area  $A$ . Let's assume that the fraction of the light reflected from the surface is  $r$ , known as the luminance factor (often subscripted with a "d"). Given an illuminance  $E$  lighting the surface we want to determine the luminance of the surface. The amount of luminous flux hitting the surface is  $F = EA$ . The amount of flux leaving the surface is  $F' = rF = rEA$ , and must be equal to the integration of the luminous intensity over the hemispherical surface above the area  $A$ :

$$F' = rEA = \iint I(q) \, dw = I_0 \int_0^{2\pi} d\phi \int_0^{\pi/2} \cos q \sin q \, dq = 2\pi LA \int_0^1 u \, du = \pi LA, \tag{2}$$

where  $dw = \sin q \, dq \, d\phi$  is the element of solid angle. Solving for the luminance we obtain the relation between the luminance and the illuminance for a diffuse Lambertian reflector:

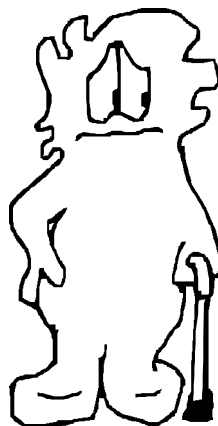
$$L = \frac{r}{\pi} E = qE, \tag{3}$$

where  $q = r/\pi$  is called the luminance coefficient.



DISCUSSIONS

Too much sitting typing up this document! The physician said I needed to lose 80 lbs of fat before I feel better.

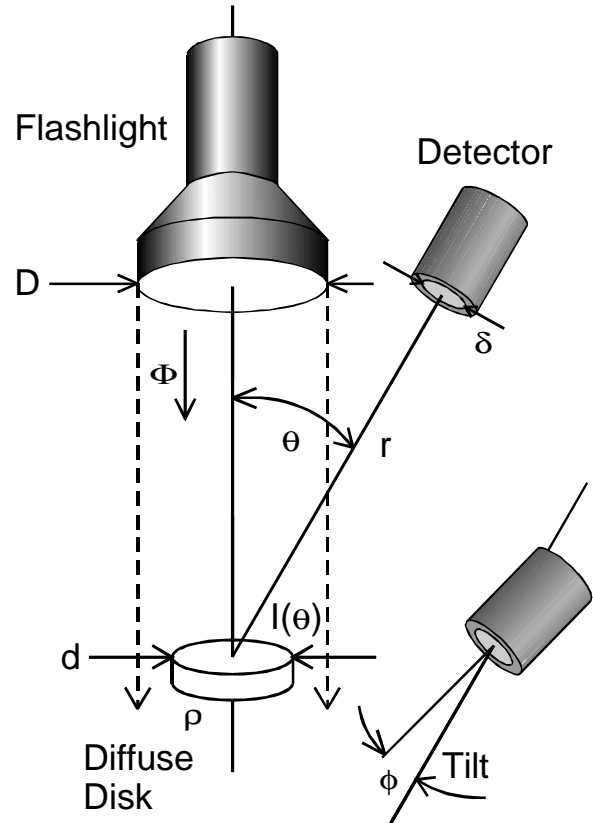


So, they're going to remove your head?!



## A207 UNIFORM COLLIMATED FLASHLIGHT

**Problem:** A Lambertian disk of reflectance  $r = 0.95$  having a diameter of  $d = 20$  mm is illuminated with a uniform collimated (parallel rays) beam of light of diameter  $D = 50$  mm from a (very special) flashlight. The output of the flashlight is  $F = 100$  lm, and all the light is contained within the beam. What is the luminous exitance  $M$  of the flashlight, what is the illuminance  $E$  on the disk, and what is the luminous intensity reflected from the disk (assuming that the disk is small compared to the observation distance)? Given a photopic detector (like a photodiode with a photopic filter) having a diameter  $d = 5$  mm and sensitivity of  $k = 6$  A/lm, what is the output  $J$  in amps (A) of the detector as a function of angle from the perpendicular  $q$  with the detector placed at a distance  $r = 300$  mm and with the detector always facing the disk (its axis passes through the center of the disk)? Calculate the output for  $q = 30^\circ$ . How would the output of the detector change if it is tilted an angle  $f = 60^\circ$  from directly facing the disk?



The luminous exitance  $M$  is simply the luminous flux  $F = 100$  lm divided by the area

$$A = \pi D^2/4 = 0.00196 \text{ m}^2 \quad (1)$$

( $D = 0.05$  m) of the aperture of the flashlight, or

$$M = \frac{F}{A} = \frac{4F}{\pi D^2} = 50930 \text{ lm/m}^2. \quad (2)$$

Because the beam is collimated it remains the same diameter along its path (hard or impossible to do in reality, but some spotlights come fairly close). Therefore, the illuminance on the white disk is the same as the luminous exitance:

$$E = F/A = 50930 \text{ lx.} \quad (3)$$

(Note that whereas illuminance is in lx, luminous exitance is expressed in  $\text{lm/m}^2$ .) The luminance  $L$  of a diffuse object normally illuminated with illuminance  $E$  (see A203) is given by

$$L = qE = \frac{r}{\pi} E = 15400 \text{ cd/m}^2. \quad (4)$$

The luminous intensity  $I$  from a Lambertian reflector (A206) having a luminance  $L$  and area  $a = \pi d^2/4 = 3.14 \times 10^{-4} \text{ m}^2$  is given by

$$I = I(q) = I_0 \cos q = aL \cos q, \quad (5)$$

provided that the distance  $r$  at which  $I$  is observed is large compared to the diameter of the disk  $d$ , that is,  $r \gg d$ . (See A210 for an exact calculation of the illuminance from a Lambertian emitter.) Here the maximum luminous intensity  $I_0$  along the normal of the disk is  $I_0 = La = 4.838$  cd.

This light enters through the aperture (diameter  $d = 0.005$  m, area  $a = \pi d^2/4 = 1.963 \times 10^{-5} \text{ m}^2$ ) of the detector placed a distance  $r$  away. Since the output of the detector in amps ( $J = kF$ ,  $k = 6$  A/lm) depends upon the luminous flux entering the aperture, which we will call  $F$  to avoid confusion with  $F$ ; we need to determine  $F$  from the luminous intensity  $I$ . We know the solid angle of the detector as viewed from the center of the disk is given by

$$w = \frac{a}{r^2} = \frac{\pi d^2}{4r^2} = 2.182 \times 10^{-4} \text{ sr}. \quad (6)$$

The luminous flux entering the detector is the product of the luminous intensity and the solid angle

$$F = I(q)w = Law \cos q = \frac{r}{\pi} F \frac{d^2}{D^2} a \frac{\cos q}{r^2} = F_0 \cos q, \quad (7)$$



where  $F_0 = I_0 w = 1.056 \times 10^{-3}$  lm is the maximum flux at the normal position if the detector could be placed there without interfering with the illumination of the disk. The output of the detector is simply

$$J = k F = J_0 \cos q, \tag{8}$$

where  $J_0 = 6.33$  mA is the limiting current possible for this configuration. For  $q = 30^\circ$  we obtain  $F = 9.141 \times 10^{-4}$  lm and  $J = 5.48$  mA.

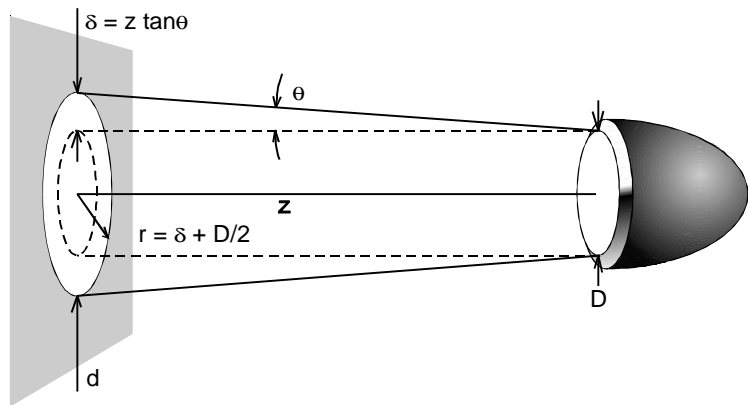
If we were to turn the detector so that the normal of the detector surface makes a tilt angle of  $f = 60^\circ$  from the line from the center of the disk to the center of the detector, we would simply need another cosine term. The signal would then be

$$J = J_0 \cos q \cos f = 2.74 \text{ mA.}, \tag{9}$$

using  $q = 30^\circ$  and  $f = 60^\circ$ .

## A208 HEADLIGHT (DIVERGENT UNIFORM FLASHLIGHT)

**Problem:** Given a uniform divergent flashlight, a motorcycle headlight, with luminous flux  $F = 250$  lm, diameter  $D = 100$  mm, and diverging at an angle of  $q = 2^\circ$  in all directions from its surface perpendicular; calculate the illuminance as a function of distance  $z$  from the surface of the headlight, then express the luminance as a function of distance of the headlight from a white wall with diffuse (Lambertian) reflectance of  $r = 0.91$  ( $z=0$  when the headlight is touching the wall). Now, suppose you are riding your motorcycle at night and you are just able to see a white sign (like our wall) at a distance of  $z_1 = 100$  m. You would like to be able to see further than that. You see an advertisement for a special headlight that is twice as bright as your stock headlight and they claim that you can see twice as far as a consequence. Is that claim true?



The light is spread uniformly over an area  $a = \pi r^2$  on the wall, where the radius  $r = d + D/2$ , and  $d = z \tan q$  is the extension of the radius of the beam from the original radius of the beam ( $D/2$ ) as we move out along  $z$ . Specifically, the area of the beam spot on the wall is

$$a = \pi \left( \frac{D}{2} + z \tan q \right)^2. \tag{1}$$

The illuminance is simply the luminous flux spread over the beam spot on the wall

$$E = \frac{F}{a} = \frac{4F}{\pi(D + 2z \tan q)^2}. \tag{2}$$

Since the wall is a Lambertian surface the luminance is given by (A206)

$$L = \frac{r}{\pi} E = \frac{4rF}{\pi^2(D + 2z \tan q)^2}. \tag{3}$$

If you were a small bug on the headlight and the headlight were placed against the wall so that  $z = 0$ , the illuminance would be a maximum of

$$E_{\max} = \frac{F}{\pi(D/2)^2} = 3183 \text{ lx} = M \text{ [in lm/m}^2\text{]} \text{ (for } z = 0\text{)}, \tag{5}$$

which is the luminous exitance  $M$  of the headlight. The associated maximum luminance would be

$$L_{\max} = \frac{rF}{\pi^2(D/2)^2} = 9220 \text{ cd/m}^2 \text{ (for } z = 0\text{)}. \tag{6}$$

We can solve for  $z$  in the exact expression for luminance (Eq. 3) to get

DISCUSSIONS



$$z = \frac{1}{\tan q} \left( \sqrt{\frac{rF}{\pi^2 L} - \frac{D}{2}} \right), \quad (7)$$

and use this to determine the new distance with the improved light.

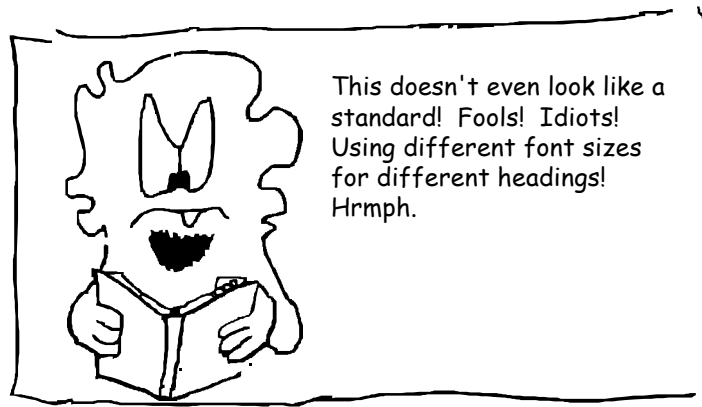
To examine the claims of the advertisement, we could use the exact equations (Eqs. 3, 7), but we note that for long distances  $z \gg D$  approximate equations will be sufficient:

$$L \cong \frac{rF}{(\pi z \tan q)^2}, \quad z \cong \frac{1}{\pi \tan q} \sqrt{\frac{rF}{L}}, \quad \text{for } z \gg D. \quad (8)$$

(Note the  $1/z^2$  behavior in the luminance.) For  $z_1 = 100$  m the luminance of a white object like the wall would be  $L_1 = 1.89$  cd/m<sup>2</sup>. We want to determine the new distance  $z_2$  at which the luminance will be the same  $L_2 = L_1$  for a headlight with twice the output,  $F_2 = 2F_1 = 500$  lm. Using Eq. 8 we find  $z_2 = 141$  m. Thus, the claim is incorrect. Twice the output only gives you a 41 % increase in the usable distance. This is obvious using the approximate Eq. (8) and writing the ratios

$$\frac{L_2}{L_1} = \frac{F_2 z_1^2}{F_1 z_2^2}, \quad \frac{z_2}{z_1} = \sqrt{\frac{F_2 L_1}{F_1 L_2}}, \quad (8)$$

in general. Using  $L_1 = L_2$  and  $F_2 = 2F_1$ , then  $z_2 / z_1 = \sqrt{2}$ , as we obtained above.





## A209 NONLINEAR RESPONSE OF EYE

The human visual system is highly nonlinear, and this nonlinearity involves spatio-temporal properties of the light stimulus as well as adaptation levels of the eye and chromatic dependencies. However, standards bodies and display technologies adopt the following rule of thumb: "Roughly speaking, perceived lightness is the cube root of luminance." (C. A. Poynton, SMPTE Journal, December 1993, p. 1101). This law appears in the uniform color spaces such as CIELUV and CIELAB (see Section A201).

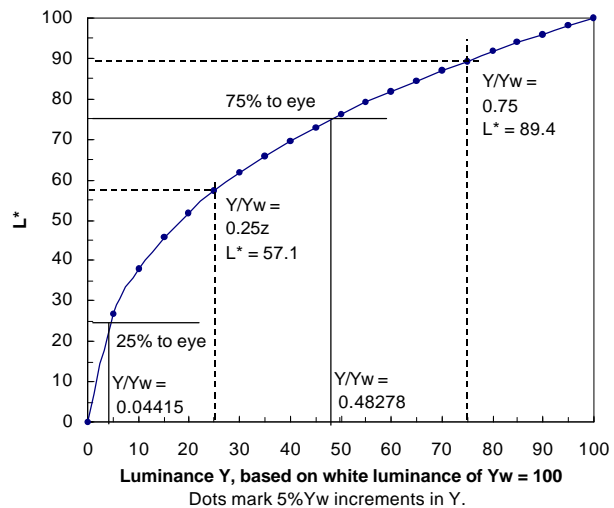
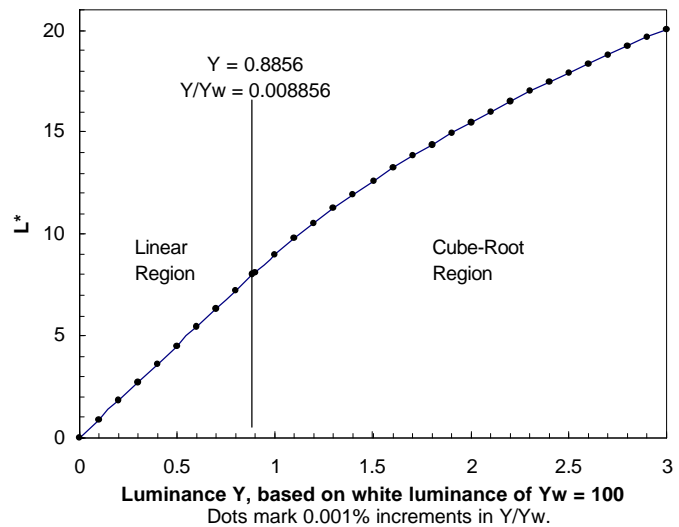
The cube-root law is the result of experiments such as the following: An observer is given a black and a white chip and asked to select a gray chip that is halfway between the two in lightness (on a particular background, and under a given illuminant). Then, the observer is asked to halve the black-gray and gray-white intervals by the same procedure. Continuing this process yields a series of chips that are subjectively equally spaced, and are assigned numerically equal increments of lightness. The measured luminances of these chips complete the lightness-luminance relationship, which has the appearance of a power function, most characteristically the cube-root function. What this means is that if the luminance  $L_1$  of one object appears to the eye to be half the luminance of another object  $L_2$ , then their luminance ratio is approximately 8:1;  $\sqrt[3]{L_2/L_1} = 2$ , so then  $L_2/L_1 = 8$ . Thus, if we have a computer display that has a luminance of 100  $\text{cd/m}^2$  and want a new display to appear twice as bright, then we would need the new display to have a luminance of 800  $\text{cd/m}^2$ .

Many modern displays are capable of a virtually continuous luminance range from black to white, and low luminance values are readily available and observable. Therefore, the best eye model to use to deal with the entire display luminance range is  $L^*$  in the CIELUV and CIELAB color spaces ( $L^*$  is the same for both spaces)—see Section A101 (Photometry and Colorimetry Summary) for details. Given a luminance  $Y$  and white luminance of  $Y_w$ , the relationship between  $L^*$  and the ratio  $Y/Y_w$ :

$$L^* = \begin{cases} 116 \left( \frac{Y}{Y_w} \right)^{1/3} - 16, & \text{for } \frac{Y}{Y_w} \geq 0.008856 \\ 903.3 \frac{Y}{Y_w}, & \text{for } \frac{Y}{Y_w} \leq 0.008856 \end{cases}$$

$$\frac{Y}{Y_w} = \left( \frac{L^* + 16}{116} \right)^3, \text{ but } \frac{Y}{Y_w} = \frac{L^*}{903.3}, \text{ for } L^* < 8$$

Be careful not to confuse the linear luminance space with the nonlinear eye response characterized by  $L^*$ . For example, a pixel may be considered stuck on if its luminance is always greater than 75 % of white and stuck off if its luminance is always less than 25 % of white. Don't confuse this with what the eye sees. A pixel with 25 % white luminance appears to the eye to be 57 % of the white brightness; similarly 75 %, appears to the eye as 89 %. If we wanted to judge the pixel based on appearance thresholds of 25 % and 75 % of white, we would use the luminance-of-white criteria of 4.415 % and 48.28 %.



DISCUSSIONS



## A210 $E(z)$ FROM EXIT PORT OF INTEGRATING SPHERE

**Problem:** Given a  $D = 50$  mm exit port of an integrating sphere with uniform luminance of  $L = 5000$  cd/m<sup>2</sup>, determine the illuminance as a function of distance  $E(z)$  from the exit port along the axis of the exit port. At what distance can the exit port be treated as a point source of light with less than 1 % error?

We calculate the contribution  $dE$  to the total illuminance from an element of area  $dA$  in the plane of the exit port. We consider an area  $a$  at position  $z$  from the center of the exit port. The luminous intensity from  $dA$  is

$$dI = LdA \cos q, \quad (1)$$

where the cosine term arises from the Lambertian nature of the emission from the exit port. (This equation is simply the definition of luminance:  $L = dI/dA$ , see A203.) The area  $a$  subtends a solid angle of

$$w = (a/r^2) \cos q \quad (2)$$

from the viewpoint of the area element  $dA$ . Here the cosine term comes from the fact that the area  $a$  is also tilted with respect to the line between  $dA$  and  $a$ . Not only is the emission from  $dA$  decreased by the cosine term, but the amount of light through  $a$  is also decreased by the cosine term because the area  $a$  is not facing the element  $dA$  (the surface normal of  $a$  is not pointing at  $dA$ ). The area element  $dA$  is the product the arc arising from  $d\phi$  ( $d\phi$  times the radius in the plane of the exit port  $r \sin q$ ) and the arc arising from  $d\theta$  (since we are confined to the plane of the exit port, the radial arc length  $rd\theta$  must be extended to  $rd\theta/\cos q$ ), or

$$dA = r^2 (\sin q / \cos q) d\theta d\phi. \quad (3)$$

The amount of flux  $dF$  passing through  $a$  from  $dA$  is then

$$dF = w dI = LdA \frac{a}{r^2} \cos^2 q, \quad (4)$$

and the illuminance contribution is

$$dE = \frac{dF}{a} = L \sin q \cos q d\theta d\phi, \quad (5)$$

where we have used the expression for the element of area  $dA$ . Integrating this over the exit port gives the illuminance as a function of  $z$ . Note that  $\phi$  runs from 0 to  $2\pi$  and  $q$  runs from 0 to  $q_{\max}$ , where  $q_{\max}$  is given by

$$\sin q_{\max} = \frac{R}{\sqrt{R^2 + z^2}}, \quad (6)$$

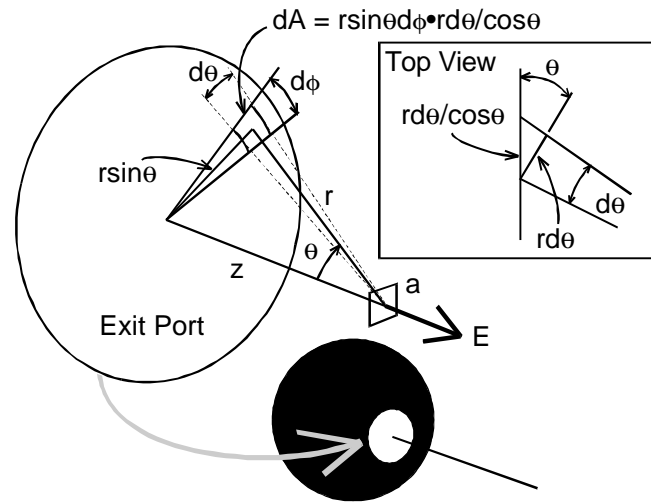
and where  $R$  is the radius of the exit port,  $R = D/2 = 25$  mm. The illuminance is

$$E(z) = \int_0^{2\pi} d\phi \int_0^{q_{\max}} L \sin q \cos q dq = 2\pi L \int_0^{q_{\max}} u du = 2\pi L (\sin^2 q_{\max}) / 2, \quad (7)$$

(using the substitution  $u = \sin q$ ) or

$$E(z) = \frac{\pi R^2 L}{R^2 + z^2} = \frac{\pi L}{1 + (z/R)^2} = \pi L \sin^2 q_{\max}. \quad (8)$$

Let's examine the values for  $z = 0$  and  $z \gg R$  and compare:





$$E(z) = \begin{cases} \pi L, & \text{for } z = 0 \\ \frac{\pi R^2 L}{z^2}, & \text{for } z \gg R \\ \pi R \sin q, & \text{for all } z \text{ and all } R. \end{cases} \quad \left\{ \begin{array}{l} = I_0 / z^2, \text{ using } I_0 = LA \\ \text{(Treats exit port as point source [} A = \pi R^2 \text{]).} \\ = LW, \text{ using } W = A / z^2 = \pi R^2 / z^2 \\ W \text{ is solid angle of exit port from } z \end{array} \right. \quad (9)$$

Here  $A$  is the total area of the exit port, and  $W$  is the solid angle of the exit port as viewed from the  $z$ -position. The result for  $z = 0$  is what we get in A215 where we derive the relationship between the illuminance and luminance of the walls of an integrating sphere. The large- $z$  approximation essentially treats the exit port as a point source with a  $1/z^2$  dependence. Comparing the exact expression for the illuminance (Eq. 8) with the large- $z$  expression (Eq. 9) amounts to comparing  $R^2/z^2$  with  $R^2/(R^2 + z^2)$ . These two functions differ by slightly less than 1 % when  $z = 10R = 5D$ . Thus, we can use the simple forms in Eq. 9 for Lambertian emitters whenever we are more than five diameters away from the light source and be within 1 % of the exact result.

A simpler way to obtain the result in Eq. 8 is to consider a spherical cap defined by the exit port where the cap extends inside the integrating sphere. The normal of each area element  $dA$  on the spherical cap points toward our observation point at  $z$  with luminance intensity of  $dI = LdA/r^2$ . The element of illuminance  $dE = LdW$  simply integrates to  $E(z) = \pi L \sin^2 q$ .

## A211 EXIT PORT ILLUMINATION OF DIFFUSE SURFACE

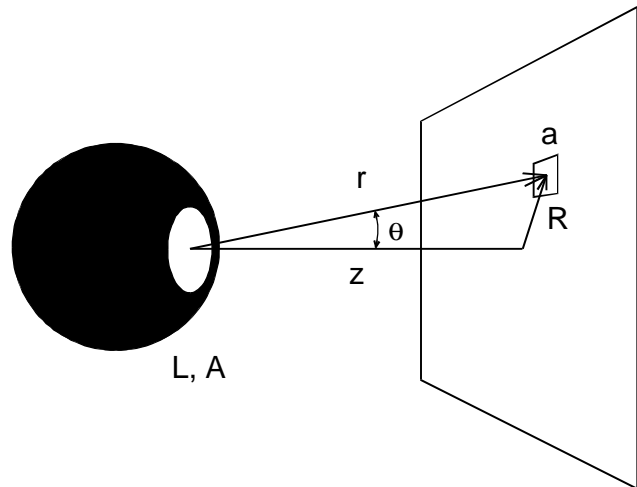
**Problem:** Given a  $D = 50$  mm exit port of an integrating sphere with uniform luminance of  $L = 5000$  cd/m<sup>2</sup>, determine the radial distribution of the luminance on a wall having a luminance factor of  $r = 0.75$  as a function of distance  $z$  from the exit port for large  $z$  compared to the exit port diameter ( $z > 5D$ ). Assume the exit port surface is parallel to the wall. Essentially this is a calculation of  $L(z,r)$  on the wall. What is the maximum wall luminance if  $z = 1$  m? How would the problem change if instead of an integrating sphere we used a light bulb that produced a uniform luminous intensity  $I$  radially about its center (can assume lamp also has a flux of  $F$ ).

Since the distance  $z$  is large we can use the results of the previous section and treat the exit port as a point source with the luminous intensity expressed by  $I = LA \cos q$ , where  $A$  is the area of the exit port,  $A = \pi D^2/4 = 0.00196$  m<sup>2</sup>. Consider a small area  $a$  a distance  $R$  from the center of the wall defined by the normal of the exit port. The distance from the exit port to  $a$  is  $r = \sqrt{z^2 + R^2} = z / \cos q$ , where the angle between the radius vector and the normal of the exit port is  $q = \text{atan}(R/z)$ , or  $\tan q = R/z$ , etc. The solid angle of that area  $a$  as viewed from the center of the exit port is  $W = (a/r^2) \cos q$ , where the cosine factor arises from the tilt of  $a$  relative to the radius vector. The luminous flux through  $a$  is simply

$$F = IW = LA \frac{a}{r^2} \cos^2 q = aLA \frac{\cos^4 q}{z^2},$$

where we have used the fact that  $r = z/\cos q$ . The illuminance on the wall  $E = F/a$  and the luminance of the wall  $L_w = rE/\pi$  are given by

$$E = LA \frac{\cos^4 q}{z^2} = LA \frac{z^2}{(R^2 + z^2)^2},$$



DISCUSSIONS



$$L_w = \frac{r}{\pi} LA \frac{\cos^4 q}{z^2} = \frac{r}{\pi} LA \frac{z^2}{(R^2 + z^2)^2}$$

The fourth power of the cosine will appear again in A213 with a very similar derivation. It is referred to as the  $\cos^4$  illumination law. The maximum luminance occurs at  $R = 0$ . With a distance of  $z = 1$  m the maximum luminance is given by  $L_{\max} = rLA / \pi z^2 = 2.34 \text{ cd/m}^2$ .

This problem has been treated as if the apparatus were in a very large room with totally black walls and with equipment that doesn't reflect any light (an impossible situation). If you were to try this experiment and measure the luminance of object such as a white disk (instead of a wall), you would discover how much reflections from nearby objects—even black objects—will add to the measured luminance of the disk over the calculated luminance (see A216).

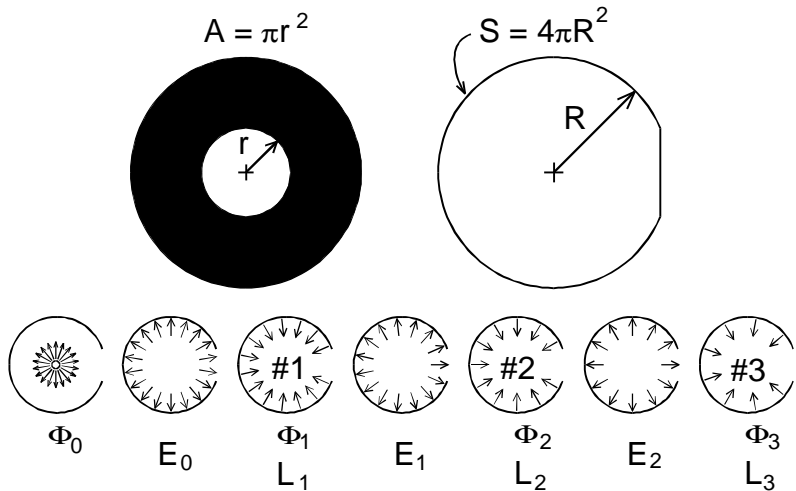
Now suppose we have a lamp having a radially uniform luminous intensity of  $I$ . The luminous flux upon a is  $F = IW$ , where as in the above,  $W = (a/r^2)\cos q = (a/z^2)\cos^3 q$ . The illuminance is  $E = F/a = (I/z^2)\cos^3 q$ . Note that the cosine term accounting for the tilt of  $a$  is already in the solid angle  $W$ . If our perfect lamp has a luminous flux output of  $F_0$  over the entire spherical region surrounding it ( $4\pi \text{ sr}$ ), then  $I = F_0/4\pi$ . The difference between using the integrating sphere vs. the lamp is that the luminous intensity from the exit port of the integrating sphere is not constant, but goes down as  $\cos q$ ; thus, introducing another cosine factor.

## A212 INTEGRATING SPHERE INTERIOR - L & E

**Problem:** Given an integrating sphere of diameter  $D = 150 \text{ mm}$  with an exit port diameter of  $d = 50 \text{ mm}$ , suppose there is a light source which illuminates the interior of the sphere uniformly with a luminous flux of  $F_0 = 100 \text{ lm}$ . Determine the luminance  $L$  of the exit port when the walls have a luminance factor of  $r = 0.98$ .

Let the area of the entire integrating sphere including the exit port be  $S = 4\pi D^2/4 = 0.0707 \text{ m}^2$ . Let the area of the exit port be  $A = \pi d^2/4 = 0.00196 \text{ m}^2$ . There are multiple reflections within the sphere.

We will assume that the luminous flux  $F_0$  is inserted into the sphere perfectly (as if we had an infinitesimally small lamp near the center of the sphere). Initially the flux incident upon the walls provides an illuminance for the first reflection of  $E_0 = F_0/S$  which produces the first contribution to the luminance  $L_1 = rE_0/\pi = rF_0/\pi S$ . At the first reflection the returned flux available for further reflections  $F_1$  is reduced from the incident flux by the reflectance  $r$  and the fact that the exit port eliminates a fraction of the light:  $F_1 = rF_0(S - A)/S$ . Historically, the factor  $(S - A)/S$  is written as  $(1 - f)$ , where  $f = A/S$  is the relative area of the exit port compared to the total area of the sphere. Thus,  $F_1 = F_0 r(1 - f)$ . The contribution to the illuminance is then  $E_1 = F_1/S$ , and the contribution to the luminance for the second reflection will be  $L_2 = rE_1/\pi = rF_1/\pi S = (rF_0/\pi S)r(1 - f)$ . The reflections continue:  $F_2 = F_1 r(1 - f) = (rF_0/\pi S)r^2(1 - f)^2$ ,  $E_2 = F_2/S$ , and  $L_3 = rE_2/\pi = rF_2/\pi S = (rF_0/\pi S)r^3(1 - f)^3$ . The general terms are, for  $n = 0$  to  $\infty$ :



$$F_n = F_0 r^n (1 - f)^n$$

$$L_{n+1} = \frac{rF_0}{\pi S} r^n (1 - f)^n \tag{1}$$

In performing the summations we note that  $1 + x + x^2 + x^3 \dots = 1/(1 - x)$  for  $x < 1$ . The total luminous flux and total luminance are given by:

DISCUSSIONS



$$F = F_0 + F_1 + F_2 + \dots = \frac{F_0}{1 - r(1 - f)}$$

$$L = L_1 + L_2 + L_3 + \dots = \frac{F_0}{\pi S} \frac{r}{1 - r(1 - f)}$$
(2)

If we had just calculated the total luminous flux inside the integrating sphere, we could have written down the luminance directly:

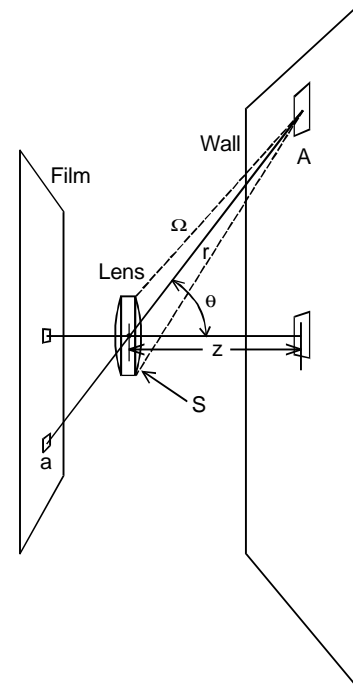
$$L = \frac{r}{\pi} E = \frac{rF}{\pi S},$$
(3)

using  $E = F/S$ . Here  $F$  is given by the expression in Eq. 2. For our numbers  $f = 0.02778$ , the luminous flux inside the sphere is  $F = 2118$  lm (compare that with the input flux of  $F_0 = 100$  lm), and the luminance is  $L = 9345$  cd/m<sup>2</sup>.

**A213 LENS  $\cos^4(\theta)$  VIGNETTE**

**Problem:** Lenses will often not provide uniform illumination over a wide angle of view. We show how a simple lens will provide a  $\cos^4 q$  fall-off in transmitted luminous flux as  $q$  increases from the axis of the lens system when the lens is viewing a surface of infinite extent that has a uniform luminance of  $L$ .

This is remarkably easy to understand. Given two planes parallel to each other—as with a camera viewing a wall. One is the object plane (infinite wall) and the other is the image plane (the film). Any area on the object plane  $A$  is focused to a corresponding area in the image plane  $a$  by a lens with area  $S$  positioned a distance  $z$  away from the wall. The wall (object plane) is assumed to be a Lambertian emitter. Therefore, this area  $A$  at angle  $q$  from the optical axis (normal to the planes) produces a luminous intensity of  $I = LA \cos q$  in the direction of the lens. The distance between the lens and area  $A$  is  $r = z/\cos q$ . This light from  $A$  hits the lens at an angle  $q$ , so the solid angle from  $A$  to the lens is  $W = S \cos q / r^2 = (S/z^2) \cos^3 q$ . The luminous flux through the lens is  $F = IW = (LAS/z^2) \cos^4 q$ . This is the light that hits the image area  $a$ , the image of  $A$ . Another cosine term does not enter in to the resulting illuminance on the image plane  $E = F/a$ ; in other words all the flux  $F$  coming from  $A$  through the lens hits the image area  $a$ . (This is not the case where we have a well-defined beam of light of a certain diameter hitting a surface at an angle so that the diameter of the beam spot on the surface increases [the spot becomes a more eccentric ellipse] as the angle increases. In such a case, the light is spread over an increasingly larger area, and the illuminance is thereby reduced by a cosine term.) Thus, two cosine terms enter because the area  $A$  is tilted to the line of sight as is the lens (one cosine comes from the Lambertian emission of light and the other from the tilt of the lens), and two cosine terms enter in because of the  $1/r^2$  nature of the illumination. Another way to look at this is: Three cosine terms arise from the solid angle of the lens (the  $1/r^2$  nature and the tilt of the lens with respect to the viewing direction along  $r$ ), and one cosine term comes from the Lambertian nature of the emitting surface.



DISCUSSIONS



## A214 ILLUMINANCE FROM LUMINANCE

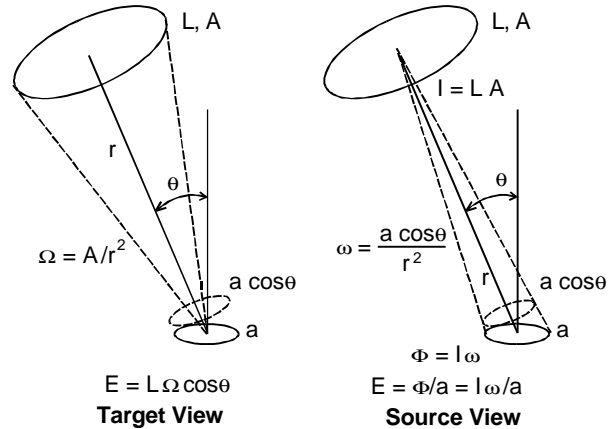
**Abstract:** Consider a uniform luminance source of diameter  $D$  illuminating a target surface at an arbitrary angle  $q$ , compare the view from the target with the view from the source, that is, compare how the target is illuminated with an illuminance from the source with how the source provides a luminous intensity for the target.

As you play with these problems, you will find that there are two ways to look at a distant light source: from the source's viewpoint or from the target's viewpoint. Consider a Lambertian emitter of area  $A$  and luminance  $L$  a distance  $r$  away from and at an angle  $q$  from the normal of a target having area  $a$ .

Suppose  $r \gg \sqrt{A}$  and also  $r \gg \sqrt{a}$ , so that we can use our approximate in A210 [ $E(z)$  from Exit Port of Integrating Sphere], where we treat distant sources as point sources. Assume that the source disk is facing the target (the normal of the disk's center intersects the center of the target disk  $a$ ).

**Source Viewpoint:** In the source view, the luminous intensity from the source  $I = LA$ , is aimed at a disk tilted at an angle of  $q$ . From the viewpoint of the source we are concerned about the solid angle of the target as viewed from the source. The solid angle of the target is therefore  $w = a \cos q / r^2$ , and the luminous flux hitting the target is simply  $F = Iw$ . The illuminance is  $E = F/a$  or  $E = LA \cos q / r^2$ . Note that the quantity  $A/r^2$  is the solid angle of the source from the viewpoint of the detector  $W = A/r^2$ . Thus, we can also write the illuminance as  $E = LW \cos q$ , where the cosine term accounts for the tilt of the target relative to the normal of the source.

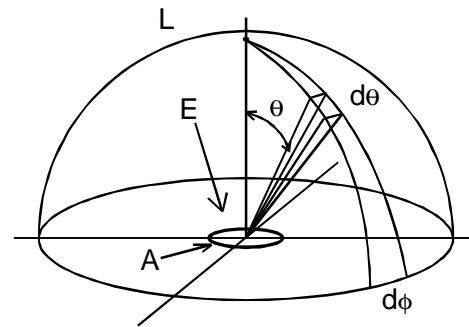
**Target Viewpoint:** This formulation  $E = LW \cos q$  appears like we are treating the source as providing an incident illuminance of  $E_0 = LW$  that arises from a luminance  $L$ . The cosine term accounts for the foreshortening of  $a$  from the off-normal position of the source. From the viewpoint of the target, we are concerned about the solid angle of the source as viewed from the target.



## A215 ILLUMINANCE INSIDE AN INTEGRATING SPHERE

**Problem:** Given an integrating sphere of diameter  $D = 150$  mm that does not have an exit port, suppose there is a light source that (coupled with the high diffuse reflectance of the interior surface) illuminates the interior of the sphere uniformly so that the luminance  $L$  of the surface of the integrating sphere is  $2000 \text{ cd/m}^2$ . What is the illuminance on the walls, and what is the illuminance on a small surface placed at the center of the integrating sphere?

Consider a disk at the center of a perfect integrating sphere having a wall (interior surface) luminance of  $L$ . We assume that the wall surfaces are Lambertian with reflectance (luminance factor)  $r$ . The illuminance on the walls  $E_s$  is then related to the luminance by  $L = rE_s/\pi$ , or  $E_s = \pi L/r$ . The only parts of the walls that contribute to the illuminance of our disk are in the hemisphere above the disk. Define a spherical coordinate system ( $q, \phi$ ) with the polar axis aligned with the normal of the disk (and at the center of the sphere). From the previous problem we can consider the luminance  $L$  from a small element of the surface giving rise to an illuminance  $dE = L d\omega \cos q$ , where  $d\omega = \sin q dq d\phi$  is the solid angle of the surface element from the center of the sphere, and the cosine term accounts for the off-axis position relative to the disk. The total illuminance upon the disk is given by the integration of the elements of illuminance:





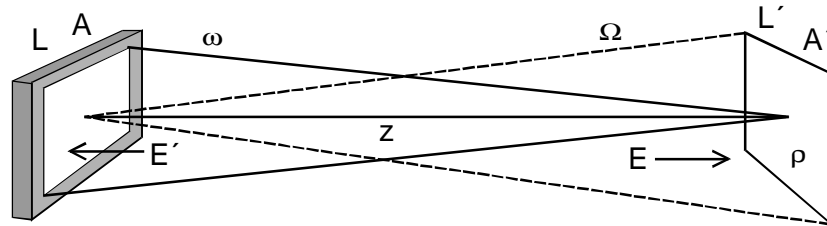
$$E = \int dE = L \int_0^{2\pi} d\phi \int_0^{\pi/2} \cos q \sin q \, dq = 2\pi L \int_0^1 u \, du = \pi L,$$

where the substitution  $u = \sin q$  was used. The illuminance on a surface centered in an integrating sphere is  $E = \pi L$  whereas the illuminance on the surface of the interior walls is slightly larger  $E_s = \pi L/r$  by the inverse of the reflectance. Why the difference? The difference comes from the fact that the illuminance on the sphere wall includes the direct illumination from the source, whereas the sample does not receive that illuminance. If you were to measure the illuminance  $E$  and luminance  $L$  on an area of the sphere wall shadowed by a baffle, then you would obtain  $E = \pi L$ .

## A216 REFLECTION FROM ROOM WALLS ONTO SCREEN

**Problem:** What can happen to your measurements when you are wearing a white shirt and standing inappropriately near the screen albeit in a darkroom? Suppose a display has a surface area  $A = 300 \text{ mm} \times 225 \text{ mm}$  and exhibits a uniform luminance of  $L = 100 \text{ cd/m}^2$ . A card of area  $A' = 300 \text{ cm} \times 300 \text{ cm}$ , luminance factor  $r_d = 0.90$ , and placed a distance  $z = 1.2 \text{ m}$  away in front of the display. What is the approximate illuminance back on the display surface that is provided by the reflected light from the board? If the screen surface has a specular reflectance of  $r_s = 0.11$  for this configuration, what is the luminance corruption of a small black square placed on the white screen? (This shows the danger of reflections from your clothes and nearby objects, and how they might influence the measurements.) Now, suppose that the walls in the room are spherical, centered on the display, with radius  $r = 3 \text{ m}$ , and having an average luminance factor of  $r_d = 0.18$ , what is the illuminance reflected back at the display. This provides a means of estimating the contribution of the environment to stray light hitting the screen that originates from the screen. Typical landscape scenes, as photographers know, reflect about 18 % of the light incident upon them.

We are making an approximation to determine how much a person standing in the vicinity of the screen wearing a white shirt will affect measurements of small black areas. Since an approximate value



is called for in the first part of the problem, we will use the long-distance approximations developed in A210 to avoid the complicated integrations that a full treatment would require. The luminous intensity from the display is  $I = LA \cos q$ , where  $q$  is the angle from the normal of the display. Since we assume the card is centered at and perpendicular to the normal of the display, we can use  $I = LA$ . With  $A = 6.750 \times 10^{-2} \text{ m}^2$ , then  $I = 6.75 \text{ cd}$ . The amount of luminous flux hitting the card is  $F = I W = 0.6075 \text{ lm}$ , where  $W = A'/z^2 = 0.0090 \text{ sr}$  is the solid angle of the card as viewed from the screen. The illuminance on the card is simply  $E = F/A' = LA/z^2 = 4.69 \text{ lx}$ . Notice that this expression for  $E$  is what we would have obtained if we had considered luminance in the determination of the illuminance  $E = Lw = LA/z^2$ , where  $w = A/z^2$  is the solid angle of the display screen from the viewpoint of the card (see A214). The luminance of the card (assuming Lambertian) is  $L' = r_d E/\pi = 1.34 \text{ cd/m}^2$ .

Consider the **specular reflectance**  $r_s = 0.11$  for this configuration. With specular reflection we will use the model that the reflected luminance is proportional to the luminance of the reflected object with proportionality constant  $r_s$ . The black corrupting luminance  $L_c$  in the reflection is given by  $L_c = r_s L' = 0.148 \text{ cd/m}^2$ . This seems fairly small. But suppose you have a display that is capable of contrasts of 300:1 so that the blacks—even for small areas—have luminances of  $L_{\text{blk}} = 0.333 \text{ cd/m}^2$ . The corruption of  $L_c$  relative to black  $L_{\text{blk}}$  amounts to a 44 % error. The black that you would measure is  $L_m = L_{\text{blk}} + L_c = 0.481 \text{ cd/m}^2$ , and the contrast reduces to 207:1. Of course, this assumes that should you measure a small black square on a white screen, you know what you're doing. The **veiling glare** of the lens system used in the instrumentation can contribute as much as 3 % of the white luminance if proper care is not taken (see A101). Thus, a 3 % veiling glare error  $L_g = 3 \text{ cd/m}^2$  would completely dominate any reflection errors! It would reduce the measured contrast to 33:1, which is a serious error! Veiling glare is more of a problem than people realize. Suppose you had a remarkably good lens with a 0.1 % glare for this arrangement.

DISCUSSIONS

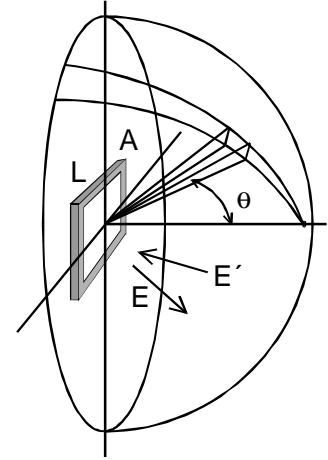


Your contribution to black would be 0.1 cd/m<sup>2</sup> which is of the same order as the black corruption from reflections. Your black measurement (including black corruption from reflection and veiling glare) would be 0.581 cd/m<sup>2</sup>, and the apparent contrast would be 172:1.

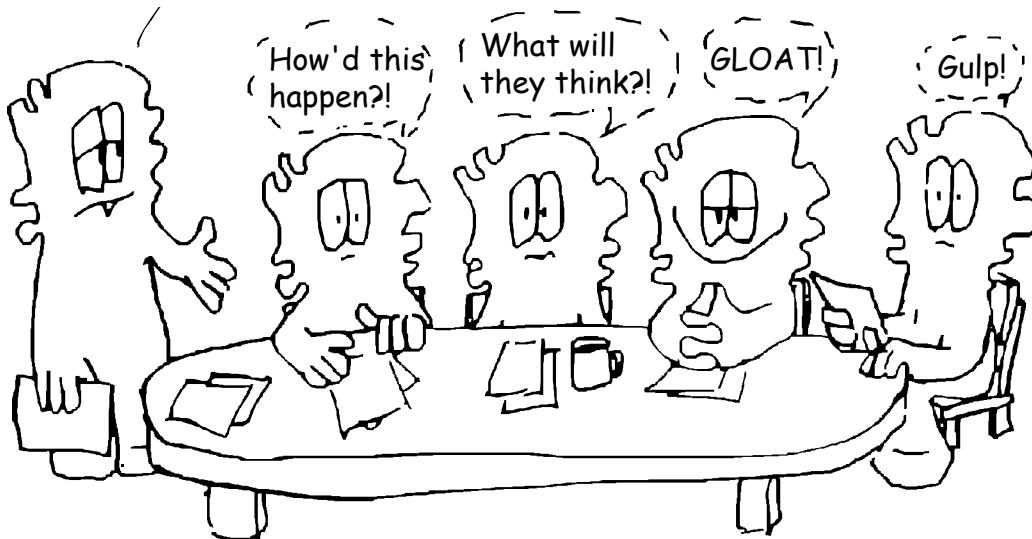
Now, consider the spherical room. We want to estimate how much light will come back on our display because of general reflections in the room from the light that the display produces. The luminous intensity from the display is  $I = LA \cos q$ . Consider an element of area  $dA = r^2 dw = r^2 \sin q dq d\phi$  on the hemisphere centered on the normal of the display with the polar axis aligned with the display normal, where  $dw = \sin q dq d\phi$  is the solid angle of the element as viewed from the center of the display. The flux hitting  $dA$  is  $dF = I dw$ . The illuminance on the element is  $E = dF/dA = I/r^2 = LA \cos q / r^2$ . The luminance (assuming Lambertian) is  $L' = r_d E / \pi = r_d LA \cos q / \pi r^2$ , whereby the maximum luminance is  $L'_{max} = r_d LA / \pi r^2 = 0.0430 \text{ cd/m}^2$ . (If the sphere were perfectly white then  $L'_{white} = LA / \pi r^2 = 0.239 \text{ cd/m}^2$ .) To obtain the illuminance reflected back on the display  $E'$  we use the idea of illuminance from the luminance of the area element:  $dE' = L' dw \cos q$ , and integrate over the hemisphere:

$$E' = \frac{r_d LA}{\pi r^2} \int_0^{2\pi} d\phi \int_0^{\pi/2} \cos^2 q \sin q dq = \frac{2r_d LA}{r^2} \left[ -\frac{u^3}{3} \right]_1^0 = \frac{2r_d LA}{3r^2},$$

where  $u = \cos q$  is used for substitution. For our quantities,  $E' = 2r_d LA / 3r^2 = 0.090 \text{ lx}$  (for a perfectly white room it would be 0.50 lx). The luminance of a perfectly white diffuse standard being hit with  $E'$  would be  $L_{std} = E' / \pi = 0.0286 \text{ cd/m}^2$  (0.159 cd/m<sup>2</sup> for a white room).



Speaking, I'm sure, for the group as the chair: It is with great reluctance that we see and agree with your logic.



JOE WINS ONE!

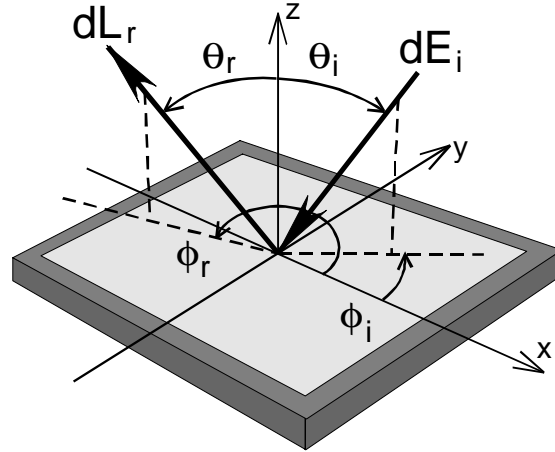
DISCUSSIONS



## A217 REFLECTION MODELS

**Abstract:** A model of the bidirectional reflectance distribution function (BRDF) is provided and three types of reflection are discussed: Lambertian (diffuse), specular (regular, mirror-like producing a distinct image), and haze.

**NOTE:** Reflection characteristics are under study. Overly simplistic models do not adequately characterize reflection for modern displays. This material is presented as an annex. No measurement is currently specified in this measurement standard to measure the BRDF or its parametric representation. When the measurement is simplified sufficiently to provide an adequate parameterization of reflection, then a procedure will be added. Until then, this represents an introduction to a more rigorous model of reflection.



**Fig. 1.** BRDF configuration showing incident and reflection directions in spherical coordinates.

### BRDF FORMALISM:

This reflection model is based on the bidirectional reflectance distribution function (BRDF).

[1] Neglecting any wavelength and polarization dependence, the BRDF is a function of two directions, the direction of the incident light ( $q_i, f_i$ ) and the direction from which the reflection is observed ( $q_r, f_r$ ) in spherical coordinates as shown in Fig. 1. The BRDF relates how any element of incident illuminance  $dE_i$  from direction ( $q_i, f_i$ ) contributes to a reflected luminance  $dL_r$  observed from direction ( $q_r, f_r$ ):

$$dL_r(q_r, f_r) = B(q_i, f_i, q_r, f_r) dE_i(q_i, f_i), \tag{1}$$

where  $B(q_i, f_i, q_r, f_r)$  is the BRDF. (In the literature the BRDF is often denoted by  $f_r$ . We use  $B$  to avoid complicated subscripts and confusion with other uses of “ $f$ ” within the display industry.) By integrating over all incident directions in space, the luminance  $L_r(q_r, f_r)$  observed from any direction ( $q_r, f_r$ ) can be determined by

$$L_r(q_r, f_r) = \int_0^{2\pi} \int_0^{\pi/2} B(q_i, f_i, q_r, f_r) dE_i(q_i, f_i). \tag{2}$$

The illuminance contributions  $dE_i$  arise from luminance sources in the room. For each element of solid angle  $dA_i/r_i^2 = d\Omega = \sin q_i dq_i df_i$  at a distance  $r_i$  from the screen there is a source luminance  $L_i(q_i, f_i)$  producing illuminance

$$dE_i = L_i(q_i, f_i) \cos q_i d\Omega = L_i(q_i, f_i) \cos q_i \sin q_i dq df, \tag{3}$$

where the cosine term accounts for the spreading of the illuminance over a larger area as the inclination angle increases.

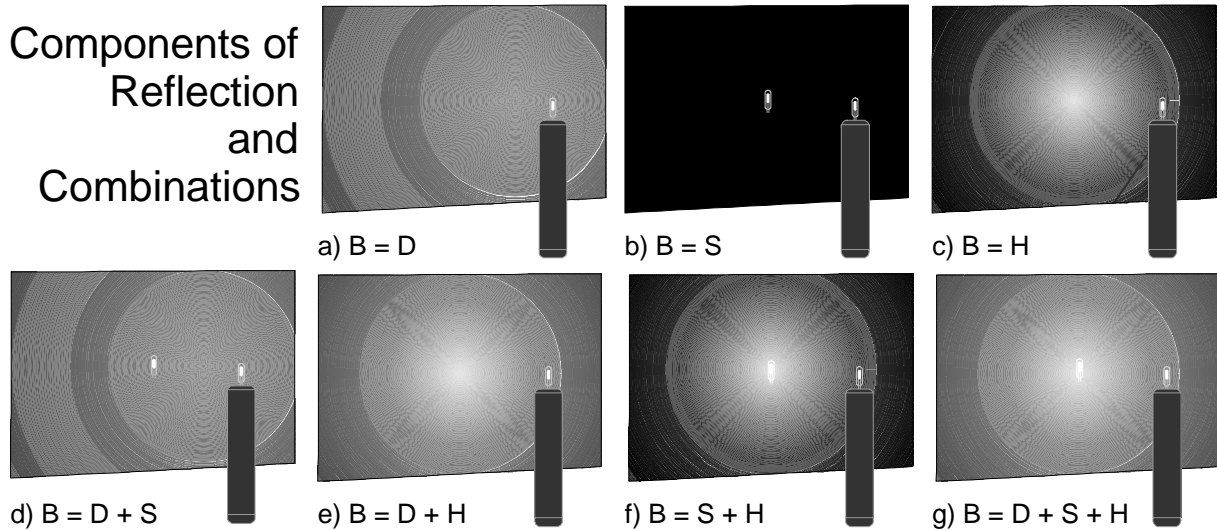
The diffuse reflection model for a Lambertian surface relates the reflected luminance to the total illuminance by  $L = qE$ , where  $q = r_d / p$  is the luminance coefficient, and  $r_d$  is the luminance factor. For purely Lambertian reflection we will call  $r_d$  the Lambertian reflectance ( $r_L$  may be appropriate). Specular reflection is characterized in terms of the luminance of the source  $L_s$  and the specular reflectance factor  $r_s$  so that the reflected luminance is given by  $L = r_s L_s$ . This is the specular reflection that produces a distinct image as does a mirror; see “distinctness-of-image gloss,” “specular reflection,” “specular,” in [2]; and “regular” in [4]. In these cases the term “specular” or “regular specular” usually refers to reflection without diffusion away from the specular direction. In this document specular reflection will be used to refer to the component of reflection that produces a distinct mirror-like image. Similarly, Lambertian reflection, as used in this document, will refer to Lambertian-like reflection—we avoid the use of the term “diffuse” since its definition is not quantitatively precise. Lambertian and specular reflection models are inadequate to characterize reflection from all displays. There is a third type of reflection that we will call haze, for want of a better term (see ASTM E-284 [2] and D-4449 [3]).

Many screens today have surfaces that disperse some of the specular light energy into other directions—a process called diffusion; the object causing the diffusion is called a diffuser (see [2]). Using a point light source

DISCUSSIONS



## Components of Reflection and Combinations



**Fig. 2.** Illustration of the three types of reflection found in modern electronic displays.  $B$  refers to the BRDF that can have a diffuse (Lambertian) component,  $D$ , a mirror-like specular component that produces a distinct image,  $S$ , and a haze component,  $H$ . One component must exist. There are four combinations of the three components. Any or all of the three components can exist nontrivially, or one component can dominate while the other two components make a trivial contribution to the reflection (as in the case of the first three illustrations).

200 mm to 500 mm away from the screen (such as a bare flashlight bulb), if you can see a distinct image of the source in the reflection then the surface has a non-trivial (regular, mirror-like) specular component. If you can see a general dark-gray background that is relatively uniform across the screen, then the screen has a non-trivial Lambertian component. If you see a fuzzy patch of light surrounding the image of the bulb (or in the specular direction) then the screen also has a haze component. In fact, the BRDF can be obtained from a measurement of the reflection distribution from a point source, but the measurement is compromised because of glare arising in the lens system used. See Fig. 2.

It is important to realize that not all components of reflection need to be observable, but least one component must exist, of course (Fig. 2a, b, c). There are displays that have entirely quasi-Lambertian diffuse surfaces (e.g., white xerographic copy paper—Fig. 2a). There are displays that don't have a specular component and have only a haze component with the Lambertian component being negligible ( $10^{-4}$  the size of the haze reflection peak in the specular direction—Fig. 2c). When the reflection of a point light source is observed in screens with only a haze component, only a fuzzy patch of light is seen in the specular direction and no distinct image of the source is observed. There are displays that don't have a substantial haze component and only exhibit specular and quasi-Lambertian reflections—Fig. 2d. Many television CRT picture tubes are of this nature. In all these cases, a multi-layer thin-film antireflection coating can be added to further reduce the reflections from the front surface of the screen making the surface of the display appear quite dark. This is especially true in the case of 2b, 2c, or 2f where the Lambertian component is either absent or negligible. Another way to view the BRDF is to hit the screen with a narrow laser beam and view the reflected light against a large white card in a dark room. The distribution of the light on the white card is the projection of the BRDF onto a plane.

We can capture these three types of reflection explicitly with the BRDF formalism in terms of three additive components: Lambertian  $D$  (for “diffuse” so there will be no confusion with luminance  $L$ ), specular reflection  $S$ , and haze  $H$ ,

$$B = D + S + H, \quad (4)$$

where the components are defined by [1]

$$\begin{aligned} D &= q = r_d / p, \\ S &= 2r_s \delta(\sin^2 q_r - \sin^2 q_i) \delta(f_r - f_i \pm p), \\ H &= H(q_i, f_i, q_r, f_r). \end{aligned} \quad (5)$$



In the specular term the delta functions  $\delta(\dots)$  are generalized functions that, roughly speaking, select the value of a function within an integral:  $f(a) = \int_{-\infty}^{+\infty} f(x)\delta(x - a)dx$ . These functions simply assure that the specular contribution only comes from whatever source may be located in the specular direction. They provide for a mirror-like distinct image of the source in the viewed reflection. When we integrate this three-component BRDF over all incident illumination directions by combining Eqs. 2-5, the reflected luminance is given by

$$L_r(q_r, f_r) = qE + r_s L_s(q_r, f_r \pm p) + \int_0^{2p} \int_0^{p/2} H(q_i, f_i, q_r, f_r) L_i(q_i, f_i) \cos(q_i) d\Omega. \quad (6)$$

The first term is the familiar Lambertian reflection where  $E$  is the total illuminance from all directions, and the luminance coefficient  $q$  is expressed in terms of the Lambertian reflectance factor  $r_d$  by  $q = r_d/p$ . The second term is the familiar specular reflection whereby the specular contribution is regulated by the specular reflectance factor  $r_s$ . The specification of  $(q_r, f_r \pm p)$  simply selects the light from the viewing direction  $(q_r, f_r)$  reflected about the normal (z-axis), i.e., the specular direction associated with the viewing direction. The last term is the haze contribution.

Because the full BRDF is a four-dimensional function (neglecting polarization and wavelength), to measure it completely would require a large amount of data and the measuring instrumentation would be expensive. However, because we are using displays, we are often able to take advantage of some simplifications that reduce the amount of data required so that this formalism is manageable. First, note that most displays are viewed from the normal direction (or at least from one direction), and the range of angles to observe the entire screen from the normal position are usually on the order of  $\pm 30^\circ$ . For electronic displays, it is often found that the shape of the BRDF does not change appreciably over this range—see Fig. 3. Thus, a reduced BRDF  $B(q_i, f_i) \equiv B(q_i, f_i, 0, 0)$  is often adequate for many reflection characterizations of displays. In the following the subscript “i” denoting the incident illumination will be dropped from the spherical coordinates and is to be understood. We will from now on be considering the reduced BRDF as being adequate for display use:

$$B(q, f) \equiv B(q_i, f_i, 0, 0).$$

If the BRDF is seen to be symmetrical about the specular direction then the BRDF is independent of  $f$ ,  $B(q, f) = B(q)$ . When the reflection of a point source is observed for a screen having a rotationally symmetrical BRDF the haze reflection will appear to be perfectly round without any spikes. For such a case, acquiring a suitable BRDF for displays amounts to taking an in-plane BRDF where the detector is held near the normal of the screen and the source is rotated about the normal in the horizontal plane. However, because of structure behind the front surface of the display, this last reduction is sometimes not possible, i.e., the BRDF is not always rotationally symmetric about the normal—see Fig. 4. For such screens, the BRDF is no longer a simple function to measure.

Methods to obtain the BRDF are well documented and will not be reviewed here. [5-8] When there is a non-trivial specular and non-trivial haze component, the measurement of the BRDF must be made carefully using well-designed apparatus where the signature of the apparatus can be used to better understand the results. [7,8] When there is just a haze component—as with a number of FPDs—the BRDF measurement can be made more easily than when a non-trivial specular component exists in addition to the haze. In Fig. 5 we show the BRDF of a sample that possesses all three components of reflection such as illustrated in Fig. 2g. The specular component is manifested by a sharp peak, the haze profile has both a peak value and a width, and the Lambertian component manifests itself as the quasi-constant

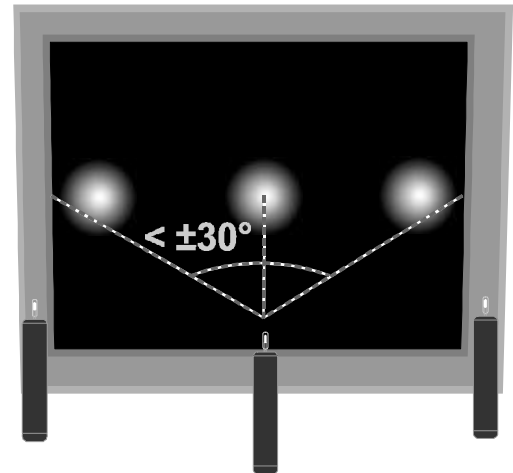


Fig. 3. For many displays, the BRDF appears to have approximately the same shape as viewed all over the screen from a single observation point near the normal.

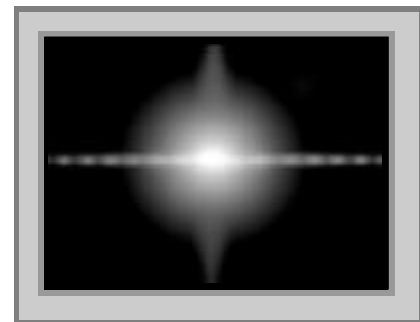
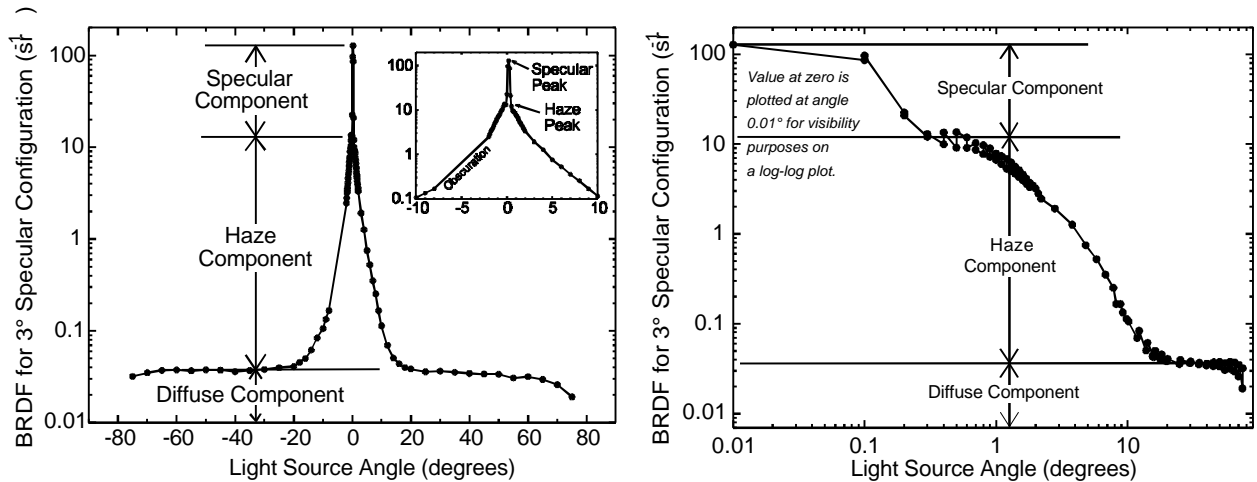


Fig. 4. A display BRDF that is not rotationally symmetric.

DISCUSSIONS



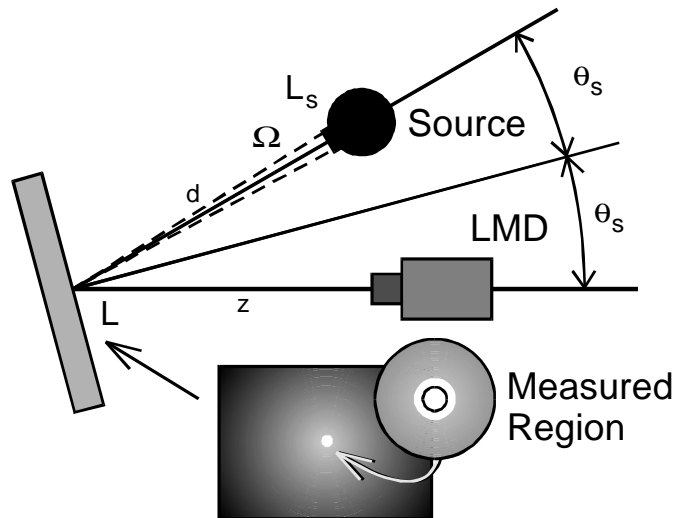
**Fig. 5.** BRDF of sample material with obvious Lambertian component. Inset shows detail of peak. The resolution of the BRDF apparatus is  $0.2^\circ$ , and a point source is employed to obtain the BRDF. Two presentations of the same data are provided; the log-log plot is useful for revealing the details at the peak.

background. In order to resolve the delta-function-like behavior of the specular component, the apparatus has a resolution of  $0.2^\circ$ . Decreasing the resolution of the apparatus (increasing its acceptance angle) will diminish the distinctness of the specular peak until it becomes unresolvable as a separate peak and is smeared in with the haze profile. The resolution of the apparatus depends upon both the detector and source configuration. You will note that, very roughly speaking, the specular component is roughly ten times the haze peak that is roughly 100 times the Lambertian component. This kind of range of magnitudes in the reflection components can be found in a number of displays. The fall-off at the angles above  $60^\circ$  may be due to sheen, which is an increase in the reflection of a surface at grazing angles where even a matte surface can appear specular. The Lambertian component would be the flat area indicated.

To better see how these three components are related, consider a very small uniform disk of light used as a source having a solid angle  $\Omega$  from the center of the screen and luminance  $L_s$ . Let's suppose we are looking in the specular direction at the reflection of the small disk, and we determine the luminance  $L$  of the center of the reflected image—see Fig. 6. Let the haze profile  $H$  have a peak of magnitude  $h$  in the specular direction. Since the size is small, the integration in Eq. 6 is simply  $hL_s\Omega = hE_s$ , where  $E_s = L_s\Omega$  is the illuminance from the source onto the screen. Then Eq. 6 simplifies to

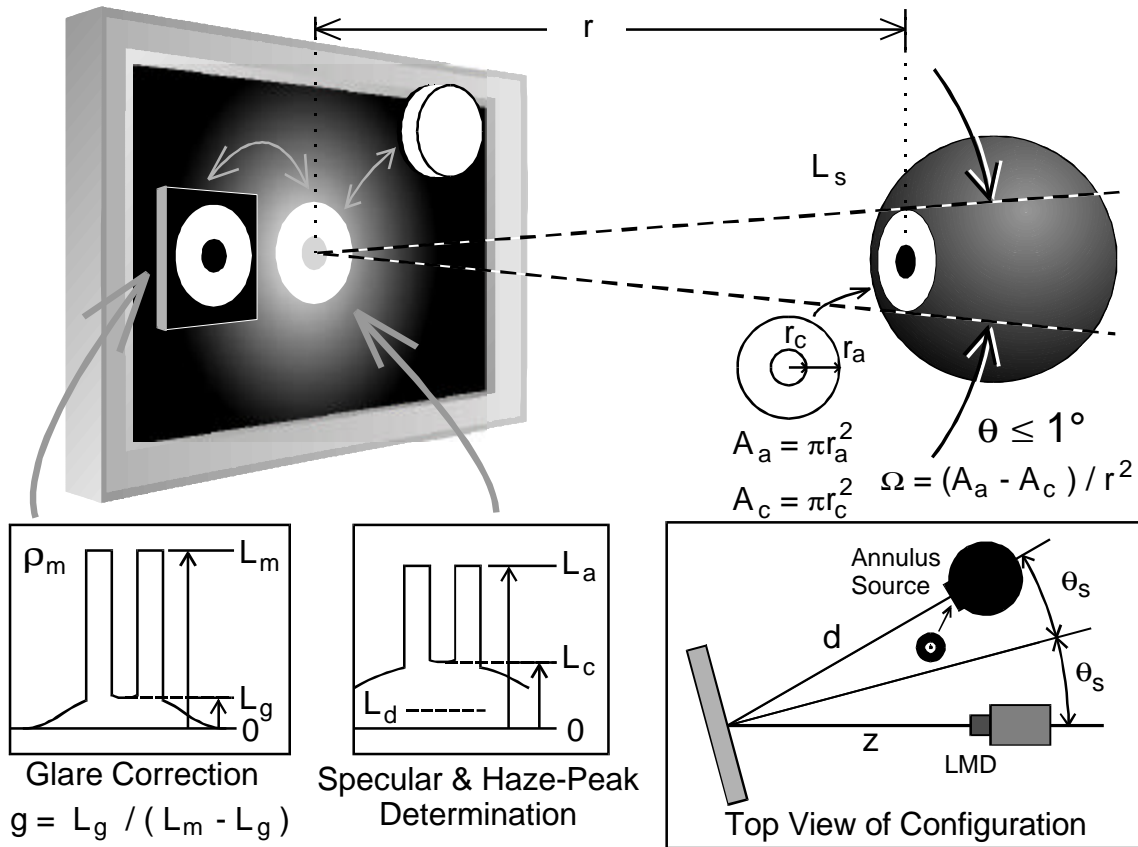
$$L = (q + h)E_s + r_sL_s. \tag{7}$$

Thus, we see that haze is like Lambertian reflection in that it is dependent upon the magnitude of the illuminance, but it is like specular reflection in that it is peaked in the specular direction. As we move the source closer to the screen (or further away) the term proportional to the illuminance increases (or decreases), but the specular term remains the same, independent of distance. This is why the eye sees the three components as separate for they each act in different ways with respect to a source of light. In fact, specular and Lambertian reflection components are the two extremes of the haze profile. One extreme shape of the haze profile (or BRDF) is to be flat (constant) as a function of angle for the Lambertian reflection. The other extreme shape of the haze profile is a delta function for the idealized specular reflection. (Of course, the delta function is a mathematical abstraction of a practical situation,



**Fig. 6.** Examination of contribution of three components of reflection from a small uniform source.

DISCUSSIONS



**Fig. 7.** View from the standpoint of the detector. A small annulus is used to separate the specular component from the haze and Lambertian components. A mirror permits the determination of the glare factor, and a diffuse white standard permits a measurement of the illuminance.

but it is a convenient mathematical construct to permit the parametric characterization of the BRDF and, hopefully, better enable calculations of reflection from luminance distributions given the screen reflection properties.)

When the front surface of the display can be placed in close proximity to the pixel surface, e.g., 1 mm or so, the specular component can be completely eliminated in favor of a haze component with a trivial Lambertian component in the background. When the front surface of the display cannot be placed near the pixel surface, then a strongly diffusing front surface cannot be used because it would obscure the pixel detail. This can be demonstrated by trying to read printing through wax paper held approximately 10 mm above the printing compared to the wax paper placed directly on the printing.

Many reflection characterizations mix the three components in different ways. For example, the reflection measurements outlined in 308-3, 4, and 5 are typical display reflection measurements used in the display industry. When displays have all three components of reflection, these types of measurements will mix the components rather than distinguish the components. Many other types of reflection measurements similarly mix some or all of the three components together. The goal of the present research is to characterize reflection in the way the eye sees screen reflections, and, if possible, develop an appropriate parameterization of the three components of reflection based upon simple measurements—a large order. In what follows, we present some recent developments toward that end.

**ATTEMPTS TO PARAMETERIZE REFLECTION CHARACTERISTICS:**

Figure 7 shows the reflection of an annular light source in the screen. Either a LMD with a very small angular field of view (AFOV) or an array LMD can be used. If the annulus is visible as a distinct virtual image, then there exists a non-trivial specular component; if not, then the measurement becomes simple, and only a haze peak plus any Lambertian contribution is present. We will assume all three components are non-trivial for this examination since that is the most difficult case. By measuring the luminance associated with the annulus as

DISCUSSIONS



reflected by the screen and as reflected in a mirror, we are able to determine the haze peak and the specular reflectance factor, provided an estimate or measurement has been made of the Lambertian reflectance contribution. The annulus subtends a small angle to attempt to take advantage of as much flatness of the haze peak as is possible, that is, the angle of subtense of the annulus is small in the hopes that the haze doesn't change significantly across the annulus. The luminance observed at the center of the black portion of the annulus is the haze and the Lambertian reflection combined,

$$L_c = (q + h)E_s, \tag{8}$$

but when we look at the ring of the annulus, we add in the specular term  $r_s L_s$ .

$$L_a = (q + h)E_s + r_s L_s \tag{9}$$

For many display technologies, the haze peak  $h$ , if present, will often be much larger than the luminance coefficient  $q$  characterizing the Lambertian component.

The Lambertian component  $D = qE_s$  can be obtained in several ways. It is important to note that for some technologies the Lambertian component is very small, three to five orders of magnitude less than the haze peak. When such is the case, only an approximate value would be required. When the Lambertian component is a few percent, it becomes easier to measure as is the case for the sample material used in Fig. 5 where the constant-value plateau is the Lambertian component. Some of the ways to obtain estimates of the Lambertian component are shown in Fig. 8. The illuminance in all cases of Fig. 8 can be measured directly with an illuminance meter or measured indirectly using a diffuse white standard placed parallel to the screen surface and in the approximate plane of the screen for which

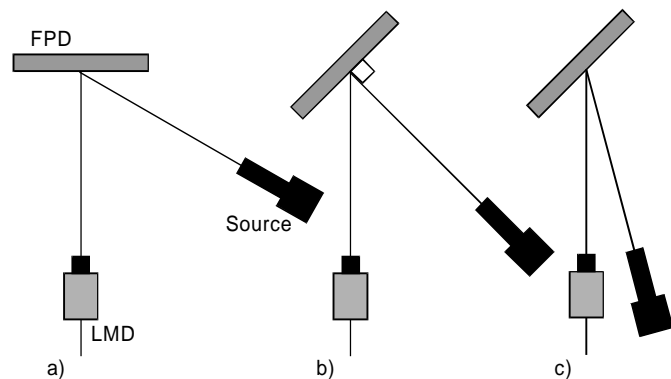
$$E = L_{std} / (r_{std} \cos q), \tag{10}$$

where  $q$  is the angle between the display and the LMD axis. The Lambertian component can also be obtained by non-linear fitting of the BRDF (with the specular component not included) to a fitting function with a constant term such as

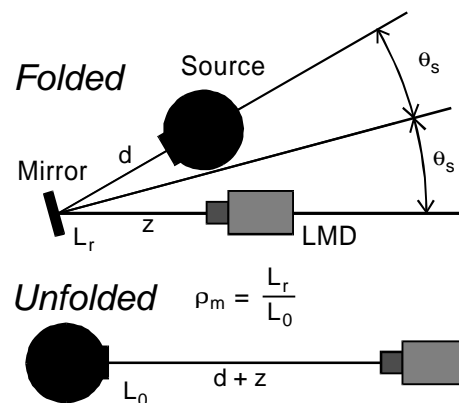
$$H + D = \frac{h}{1 + |q/w|^n + b|q/u|^m} + q, \tag{11}$$

where  $n$  and  $m$  are real numbers (not necessarily integers), and the width is characterized by  $w$  and  $u$ . Often a good fit can be obtained where  $q$  is manually set using trial values obtained by inspection of the BRDF profile. Sometimes an addition of two such functions will be needed. There is much flexibility in fitting the above function to typical BRDF curves—too much. Hopefully, more suitable functions will be found that permit low-uncertainty estimations of the shape and width parameters. However we do it, the result is the determination of  $q$ , the luminance factor.

In making measurements of the annulus, we have to be careful about glare corrections. When a mirror is put at the surface of the center of the screen, it permits the view of the source without any Lambertian or haze contributions, and that will enable a glare correction. Black glass works well since its reflected luminance is of the order of the reflected luminance of the screen (in many cases), or a quality front-surface mirror may be used. If you want to measure the source luminance (of the annulus source) using the mirror you must calibrate the reflectance of the mirror  $r_m$  at the angle  $q_s$  it is to be used. Figure 9 illustrates an arrangement where the luminance of a source is measured through the mirror in the folded configuration using the same specular angles to be used in the measurement of the display. The source can have a larger exit port than the one used for the annulus so long as the entire image of the exit port is observed in the



**Fig. 8.** By tilting the source and screen relative to the optical axis of the LMD, an estimate can be made for the Lambertian term: a) source at 60° to 70°, b) display at 45° with source perpendicular to display surface, c) source near the LMD but with the display at 45°.



**Fig. 9.** Calibration of mirror reflectance and direct measurement of source luminance.

DISCUSSIONS



mirror. (The reason for insisting that the distance  $d + z$  be preserved and that the entire exit port be visible is so that the measurement with and without the mirror will have the same geometrical configuration in order to avoid any glare problems within the lens system.) The reflectance factor for the mirror is

$$r_m = L_r / L_0, \quad (12)$$

where  $L_r$  is the reflected luminance and  $L_0$  is the source luminance used in the mirror calibration.

Referring to Fig. 7, we can measure the source luminance of the annulus  $L_s$  directly with the unfolded distance between the source and LMD being the same as when folded in the specular configuration (as in Fig. 9). We can also employ the reflectance calibration of the mirror  $r_m$  to measure the source by means of the mirror when in the folded configuration:

$$L_m - L_g = r_m L_s, \quad (13)$$

where the annulus luminance through the mirror is  $L_m$  and the luminance of the glare at the center of the annulus through the mirror is  $L_g$ . In the event of some nonuniformities in the light from the annulus, it is wise to measure the annulus in several places and take an average. The glare correction factor

$$g = \frac{L_g}{L_m - L_g} \quad (14)$$

is obtained by measuring the annulus through the mirror or by measuring the annulus directly.

To determine the haze peak we will need to know the Lambertian contribution since these two terms add  $(h + q)E_s$ . The luminance of the Lambertian term  $L_d$  is given in terms of the previously determined luminance coefficient  $q$ :

$$L_d = qE_s = qL_s W = qL_s \frac{A_a - A_c}{r^2}, \quad (15)$$

where  $W$  is the solid angle associated with the annulus,  $r$  is the distance between the annulus and the screen,  $A_a$  is the area of outer diameter of the annulus, and  $A_c$  is the area of the inner diameter of the annulus. The Lambertian contribution can be determined from Eq. 15 using either a measurement of the illuminance  $E_s$  or from a knowledge of the apparatus configuration ( $A_a$ ,  $A_c$ ,  $r$ ) and the source luminance  $L_s$ . The illuminance can be measured using a diffuse white standard  $E_s = L_{std} / (r_{std} \cos q_s)$  or by direct measurement using an illuminance meter. The luminance of the source  $L_s$  may be obtained from a direct measurement of the source or through the mirror:

$$L_s = L_m - L_g, \text{ direct measurement of annulus (mirror not used), or} \quad (16)$$

$$L_s = (L_m - L_g) / r_m, \text{ using the mirror to measure luminance of annulus.} \quad (17)$$

How well  $L_d$  measures using the illuminance value,  $E_s$ , compares with the result obtained from a measurement of the annulus luminance,  $L_s$ , provides some indication of the quality of the apparatus.

The mirror is removed and the reflection of the annulus in the screen is measured. The ring of the annulus measures  $L_a$  (it is good to average the values around the ring—top, bottom, left, right) and the center measures  $L_c$ . The specular reflectance factor is simply

$$r_s = \frac{L_a - L_g}{L_s}. \quad (18)$$

The net luminance from the haze peak is obtained by subtracting the glare and the Lambertian term from the center luminance:  $L_c - gL_a - L_d = hE_s$ . Solving for the haze peak we obtain

$$h = \frac{r^2 (L_c - gL_a - L_d)}{L_s (A_a - A_c)} = \frac{L_c - gL_a - L_d}{E_s}, \quad (19)$$

where we can use either a measurement of the illuminance  $E_s$  (using a white diffuse standard or by direct measurement with an illuminance meter) or a measurement of the luminance of the annulus  $L_s$  and the associated geometry of the configuration.

We now have the specular reflectance  $r_s$ , the haze peak  $h$ , and the Lambertian luminance coefficient  $q$  that is related to the Lambertian reflectance  $r_d = \pi q$ . The area that is most difficult to measure on the BRDF is the peak(s) associated with the specular direction—the specular peak added to the haze peak. Since this method may provide those parameters, the rest of the BRDF profile can be more easily obtained using detectors with larger apertures permitting an apparatus with lower resolution.



Much needs to be done before this technique can be assured. We need to test a large variety of displays to be sure the model is applicable. The method needs to be tested so that curved-surface screens such as CRTs can be included. We need to determine the effects of the entrance pupil size of the LMD. How the sharpness of the haze peak affects the result using a finite-sized annulus needs to be determined.

#### References:

- [1] F. E. Nicodemus, J. C. Richmond, J. J. Hsia, I. W. Ginsberg, and T. Limperis, *Geometrical Considerations and Nomenclature for Reflectance*, NBS Monograph 160, October 1977.
- [2] ASTM Standards on Color and Appearance Measurement, 5<sup>th</sup> edition, E 284-95a, "Standard Terminology of Appearance," definition of haze, p. 243, 1996.
- [3] ASTM Standards on Color and Appearance Measurement, 5<sup>th</sup> edition, D 4449-90 (Reapproved 1995), "Standard Test Method for Visual Evaluation of Gloss Differences Between Surfaces of Similar Appearance," pp. 178-182, 1996. This discusses distinctness-of-image gloss and reflection haze.
- [4] ASTM Standards on Color and Appearance Measurement, 5<sup>th</sup> edition, E 179-91a, "Standard Guide for Selection of Geometric Conditions for Measurement of Reflection and Transmission Properties of Materials," pp. 210-215, 1996.
- [5] ASTM Standards on Color and Appearance Measurement, 5<sup>th</sup> edition, E 1392-90, "Standard Practice for Angle Resolved Optical Scatter Measurements on Specular or Diffuse Surfaces," pp. 439-444, 1996. Refers also to [6].
- [6] ASTM Standards on Color and Appearance Measurement, 5<sup>th</sup> edition, E 167-91, "Standard Practice for Goniophotometry of Objects and Materials," pp. 206-209, 1996.
- [7] M. E. Becker, "Evaluation and Characterization of Display Reflectance," Society for Information Display International Symposium, Boston Massachusetts, May 12-15, 1997, pp 827-830.
- [8] J. C. Stover, *Optical Scattering, Measurement and Analysis*, SPIE Optical Engineering Press, Bellingham, Wash., USA, 1995.

If it is unknown and unknowable, then  
why do we want to know it??



Hint: See A221



## A218 DIGITAL FILTERING BY MOVING WINDOW AVERAGE

**Purpose:** The purpose of this discussion is to describe a simple method of performing low pass filtering and band stop filtering by a digital moving window average filter (MWF, also known as a running average), and to describe some benefits and limitations of this approach.

Measurements such as 305-1 (Response Time) and 305-3 (Warm-Up Time Measurement) collect multiple discrete luminance values over time, and then examine the resulting luminance/time waveform for features such as maximums and minimums. The uncertainty and repeatability of this feature analysis can often be improved by filtering out sample to sample noise (low pass filtering) or by filtering out superimposed periodic “ripple” (band stop/notch filtering).

The purpose of this discussion to describe a simple method of performing low pass filtering and band stop filtering by a digital moving window average filter (MWF, also known as a running average, see glossary), and to describe some benefits and limitations of this approach. Note that there are better noise and band pass filters to be found in any book on digital filtering, and that this discussion is not intended to preclude or discourage the use of such filters. The use of the MWF is proposed for the purposes of this specification for the following reasons:

1. The MWF is one of the simplest digital filters, and is therefore relatively easy to implement, especially in limited programming environments such as spreadsheets.
2. The simplicity of the MWF also means that there is less risk of having a measurement corrupted by a bug in the digital filter, since the MWF is relatively easy to validate by hand.
3. The MWF is one of the filters most likely to be found pre-installed in equipment such as digital storage oscilloscopes.
4. The MWF, when used within the constraints listed below, yields results very close to the results of more sophisticated filters.
5. The MWF, when compared to more sophisticated filters, often yields smoother waveforms at maximums and minimums, making measurements based on maximums and minimums easier and more reproducible.
6. The MWF, when used as a ripple filter, filters out any periodic ripple waveform, including the sawtooth waveform and other more complex waveforms characteristic of FPD refresh.

### Definitions:

SampleRate = rate at which samples are collected, in samples/second

SampleCount = number of samples collected.

RawData[0...SampleCount-1] = Input array of raw data samples

FilteredData[0...SampleCount-1] = Output array of filtered data samples.

FilterPeriod = period of ripple to filter out (see discussion below).

### MovingWindowAverageFilter:

In order to be clear on just how the MWF can be accomplished, the following is a simple hypothetical pseudo-code computer program to perform the MWF:

```

FilterCount = NearestInteger(FilterPeriod / SampleRate)
FC2 = FloorInteger(FilterCount/2)
for I = FC2 TO SampleCount-(Filtercount-FC2)
{
    Sum = 0
    for J = (I - FC2) TO (I - FC2 + FilterCount -1)
        Sum = Sum + RawData[J]
    FilteredData[I] = Sum / FilterCount
}

```

Each element in the FilteredData output array is set to the average of the FilterCount elements in the RawData input array centered on the current index (I). Note that when FilterCount is an even number, the



resulting FilteredData is time shifted by  $\text{SampleRate}/2$  toward the origin. Odd values of FilterCount do not exhibit this time shift.

The filtered average is not computed in cases where the moving average window would extend outside the RawData array, as this would result in less filtering near the beginning and end of FilteredData (this causes problems in ripple filters, since the ripple is not fully suppressed at the beginning/end of FilteredData). If desired, the uncomputed elements at the beginning/end of FilteredData may be extrapolated by being set to the first/last computed elements, respectively.

**Noise Filter:**

The moving average filter may be used as a sample-to-sample noise (or low pass) filter. In this application, FilterPeriod should be a small fraction (typically  $\leq 10\%$ ) of the measured quantity. For example, when measuring a rise time of 20.0 ms, the FilterPeriod should be 2.0 ms or less to avoid excessive smoothing of the waveform to be measured.

**Ripple Filter:**

The moving average may also be used as a crude band-stop filter to filter out a recurring periodic waveform (ripple) superimposed on top of the waveform of interest. For example, an LCD frame refresh waveform with a period of 16.6 ms may be superimposed on top of a 120.0 ms turn-on waveform. In this application, FilterPeriod should be set equal to the ripple period. When correctly applied, this filter can greatly reduce the superimposed ripple. The filter may be applied multiple times to block out multiple ripple waveforms with different periods.

**Some limitations of this approach:**

FilterPeriod should equal the ripple period as accurately as possible.

FilterCount should be as large as possible (at least 10, preferably  $> 20$ ). This can be accomplished by increasing SampleRate, or by setting FilterPeriod to an integer multiple of the ripple period (but only in cases where the ripple amplitude does not vary greatly during the resulting FilterPeriod). Another approach is to digitally resample the data to yield an higher SampleRate.

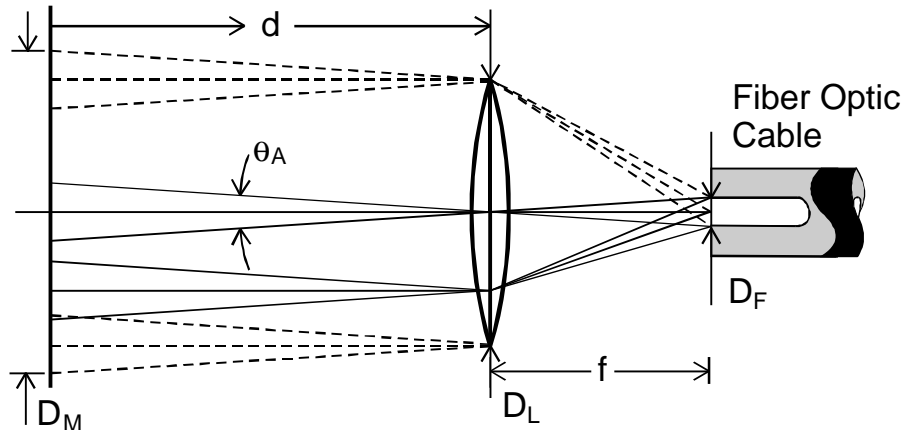
When FilterPeriod is similar to the measured quantity, the waveform of interest may itself be filtered enough to alter the measured quantity. For example, when filtering a 16.6 ms ripple waveform superimposed on top of a 25.0 ms turn-on waveform, the turn-on waveform might be smoothed enough so that the measured turn-on time is increased to 30.0 ms. This error may be acceptable, especially in cases where the turn-on time would be very difficult to measure due to the large superimposed ripple. Another approach would be to use a more sophisticated notch filter.



## A219 COLLIMATED OPTICS

**Purpose:** We introduce you to a LMD that does not image the source. These devices place a detector at the position of the focal length of the lens (not at the focus of an image). The size of the detector and the focal length of the lens determine the angles of the rays of light that contribute to the measurement. Thus, the LMD may be placed close to the surface of the display yet not accept light from a wide angle of view.

A typical spot photometer uses imaged optics, where light is focused onto a sensor at an image plane located behind the focal point of the lens system. The image is formed beyond the focal point of the lens. With collimated optics, no image is formed and the sensing device (in this case a fiber optic cable attached to the LMD) is placed at the focal point of the lens. In this way the collimated optical system can scan a large area, be close to the area, and keep all measured rays of light staying within  $\pm q_A$  of the optical axis.



*Fig. 1. Typical configuration using collimated optics.*

In the imaged optics case, the diameter of the measurement area ( $D_M$ ) is controlled by the angular field of view or aperture angle  $q_A$  and measurement distance  $d$  as follows:  $D_M = 2d \tan(q_A/2)$ . For example, if  $d = 500\text{mm}$  and  $q_A = 2^\circ$ , then  $D_M = 17.4\text{mm}$ . (Keep in mind that for these narrow angles  $q_A \approx \tan q_A$  with  $q_A$  in radians.)

In collimated optics systems, light is collected at the focal point, typically using a fiber optics cable. Since the fiber optics cable has a non-zero diameter, the system has a non-zero divergence angle  $q_A$ , as opposed to a perfect “searchlight” beam illustrated by the dotted lines parallel to the optical axis above. This divergence angle, which is equivalent to the angular field of view (or aperture or subtense angle) for an imaged system, is controlled by the collimated optics lens geometry and by the fiber optics cable diameter.

In the collimated optics case, the diameter of the measurement area is controlled by the lens diameter  $D_L$ , the aperture angle  $q_A$ , the focal length  $f$ , the diameter of the fiber  $D_F$ , and the measurement distance  $d$  as follows:  $q_A = 2 \arctan(D_F/2f)$ , and  $D_M = D_L + 2d \tan(q_A/2)$ . For example, if  $D_L = 12.5\text{mm}$ ,  $d = 100\text{mm}$ , and  $q_A = 1^\circ$ , then  $D_M = 14.2\text{mm}$ .

Since a collimated optics system does not require focusing, it may be used either close to the display (as in a goniometer), or farther from the display (to facilitate reflectance measurements), as long as the resulting measurement area is appropriate to the measurement.



## A220 MEASURES OF CONTRAST—A TUTORIAL

**Abstract:** The fidelity with which contrast is conveyed from an input pattern to the measured light on a display screen depends on the spatial variations of the pattern. This fidelity is commonly measured using one of two suites of input periodic patterns: black-and-white square waves of various spatial frequencies, and fully modulated sine waves of various spatial frequencies. For each pattern of either suite, a single number is reported, equivalent to the Michelson contrast  $(L_{\max} - L_{\min}) / (L_{\max} + L_{\min})$ . The square-wave inputs have the advantage of ease of production and measurement on a pixel-meshed screen. The sine-wave inputs have the advantage that they always generate sine-wave outputs if the transfer is linear and shift-invariant from input to output. Analysis methods based on both these suites (the latter of which is called the Modulation Transfer Function, or MTF, method) are explained in this tutorial.

### 1. MOTIVATION AND OVERVIEW

An optical system cannot accurately reproduce all of the spatial frequencies incident upon it. In particular, there is a maximum spatial frequency, known as the cutoff frequency, above which any input contrast is represented as zero output contrast. There is an inherent upper limit to the spatial-frequency spectrum in the case of a digital display; this limit is determined by the pixel spacing. No spatial-frequency information can be displayed whose pitch is less than the pixel spacing. Depending on the distance between the eye and the display, one or the other of these two factors limits the detail that can be discerned in the displayed image. If the eye is close enough to the screen to resolve the individual pixel elements, then clearly the pixel spacing determines the resolution limit. If the eye is too far away from the display to resolve individual pixels, then the limiting factor is the eye. For purposes of this tutorial, only the behavior of the display will be considered; the eye will be ignored.

How can one quantify the contrast performance of a digital display system? One sensible choice is to measure the optical transfer function (OTF), a choice that has long proven to be a very good way of characterizing high-quality optical systems. The OTF is a measure of how the contrast in an object is transferred to an image formed by an optical system, e.g., from the display to the retina in the eye. The underlying construction is to decompose (linearly, in two dimensions) the input object and output image into a Fourier series of sine and cosine waves of different spatial frequencies. Given the assumption that an optical system effects a linear transfer from object to image (and also a bit more, as will be explained in Section 3 below), all the frequency components in the input object are separately scaled in traversing the optical system, and then recombined (superposed) to produce the output image. Although the OTF is a complex function, with both real and imaginary parts, only its modulus is significant in analyzing most flat panel displays. When the blur incurred by the optics is symmetric (as is typically the case), the phase portion of the OTF can be ignored. The modulus of the OTF is typically referred to as the modulation transfer function (MTF).

A computer display can be analyzed in terms of the MTF, just as pure optical systems can. However, it must be remembered that there are differences between the traditional optical concepts and those that are operative in the digital display. One obvious difference is that the display is not purely optical but turns electrically induced input patterns to light outputs. Assuming that compensation has been made for point nonlinearities (such as gamma in a CRT), the main consequence of this fact is that, whereas light from the optical system is a continuous (analog) field, the light from a computer (flat-panel) display is more accurately represented as discrete (digital) picture elements. Hence, sine waves are not a natural representation of the digital image, even though they are convenient to manipulate using the MTF formalism. A case can be made, therefore, for using an alternative to the MTF, replacing input sine waves with square-wave patterns. This alternative is called the grille method. Rather than try to canonize the MTF or the grille method as the correct way to assess the contrast of a display as a function of spatial frequency, this tutorial discusses both methods in a common context.

Both the MTF and the grille method use the concept of spatial frequency. The former expresses the spatial frequency of a one-dimensional sine-wave test pattern through the number of cycles per millimeter; the latter expresses spatial frequency through the number of line pairs per millimeter (lp/mm), where a line pair consists of a light line next to a dark line (both having the same width). In either representation, the spatial-frequency spectrum is continuous and varies from the equivalent of “dc” to frequencies up to several thousand line pairs (or cycles) per millimeter. As the frequency increases, the MTF, and also the grille contrast response, typically decrease: the blur incurred by the optical system affects fine detail more than it affects coarse image features. To convey the further



commonality of the MTF and grille methods, we first review the grille method, and then proceed to the details of the MTF.

## 2. THE GRILLE METHOD OF QUANTIFYING CONTRAST

The grille method probes a display with several input patterns (grilles) of varying fineness, each grille being uniform in one dimension and a square wave in the perpendicular dimension. This geometry can also be described as a periodic series of bright and dark lines, usually of equal width. Fineness (spatial frequency) is defined as “line pairs per millimeter” or “line pairs per (angular) degree.”<sup>1</sup> This is analogous to temporal frequency (Hertz) except that distance or angle is used instead of time. In the case of a computer display, a screen that is entirely one gray level would have a spatial frequency of zero.<sup>2</sup> When the display has a series of black and white bars, each approximately 25 mm (1 in) wide, then the spatial frequency is 0.04 lines per millimeter or 0.02 line pairs per millimeter. If there are about 25 pairs of black and white lines in 25 mm, then the spatial frequency would be 1 line pair per mm.

For each spatial frequency of the input square wave, a single number is measured on the output pattern (which is no longer a square wave) that represents the contrast of that output wave. This number is referred to as the Michelson contrast (Boynton, 1966), defined as

$$C_m = \frac{L_{\max} - L_{\min}}{L_{\max} + L_{\min}}$$

where  $L_{\max}$  is the maximum luminance from the brightest portion of the image, and  $L_{\min}$  is the minimum luminance from the dimmest portion of the image. The Michelson contrast has a range of values between zero and one. Suppose one value of Michelson contrast is measured for each spatial frequency of input grille. Each such number is called a *grille contrast*, and the set of such numbers might be called a grille contrast function, in analogy with the MTF. Unlike the MTF, however, the grille contrast does not convey all the information about the grille distortion in passing from input to output.

An alternative, yet equivalent, performance metric to  $C_m$  is contrast ratio  $C_R$ , defined as

$$C_R = \frac{L_{\max}}{L_{\min}}$$

The value of  $C_R$  (equivalent to  $C_G$  in Section 303-2 or  $C_R$  in 302-3) can be quite large, since the denominator can become small for a very good display in a dark room. Michelson contrast and contrast ratio are related to one another as follows:

$$C_m = \frac{C_R - 1}{C_R + 1} \quad \text{and} \quad C_R = \frac{1 + C_m}{1 - C_m}$$

It should be noted that  $C_m$  is traditionally used to characterize CRT displays, so the use of  $C_m$  would facilitate comparisons of FPDs and CRTs. However, note that  $C_m$  is relatively insensitive to comparisons involving high contrasts. If there is some ambient light that is reflected or scattered towards the user, then  $L_{\min}$  will not be zero and the Michelson contrast will never reach 100%. Of course, in a dark room, there will be essentially no ambient light and the Michelson contrast would be expected to be able to approach unity.

These remarks illustrate the different representations of contrast that are equivalent to the Michelson contrast. However, the Michelson contrast itself has a distinguished status among all these representations, because it is precisely what is evaluated in MTF analysis (albeit for different input patterns). This will be clear in Section 3.

## 3. THE MODULATION TRANSFER FUNCTION

The following introduces the MTF in general terms; the application of the MTF in a CRT-measurement context is more fully discussed in EIA (1990), and can be carried over directly to flat-panel displays.

<sup>1</sup> These two measures are essentially the same. The selection of which one is used depends on the geometry of the situation. If the spatial frequency is measured on a display, it may be convenient to measure the periodic pattern in terms of lines per millimeter. On the other hand, if one is looking at a target, then the distance between the eye and the target will affect the spatial frequency and then the angular metric may be more appropriate.

<sup>2</sup> Strictly speaking, such a display will have a “zero” or “dc” spatial frequency of the reciprocal of the width or height of the display.



### 3-1. Representing linear systems by convolutions

In order for a linear system to have a defined MTF, it must be *shift-invariant*, i.e., the outputs associated with a given input (in space or time) must not depend on the space or time at which a given input is delivered. Furthermore, the attribute of linearity means that (i) if input  $I$  produces output  $I'$ , then a scaled version of the input  $kI$  produces output  $kI'$ ; and (ii) if input  $I_1$  produces output  $I'_1$ , and input  $I_2$  produces output  $I'_2$ , then input  $I_1 + I_2$  produces output  $I'_1 + I'_2$ . These properties can be shown to imply that the operation of the linear device can be represented as a convolution on the input to produce the output.

In two spatial dimensions,

$$I'(x, y) = \int_{-\infty}^{\infty} \int_{-\infty}^{\infty} T(x', y') I(x - x', y - y') dx' dy' \equiv T(x, y) * I(x, y) \quad (1)$$

where  $T(x, y)$  is called the *point-spread function* of the system, and the star denotes convolution. Although  $T(x, y)$  characterizes the system independent of the inputs and outputs, the function  $T(x, y)$  can be measured by using a unit point of input (the delta function, whose value is zero except at one spatial location, and whose integral over all  $x$ - $y$  space is 1), and recording the value  $I'(x, y)$  at all output times. Hence the name point-spread function.

In one spatial dimension,

$$I'(x) = \int_{-\infty}^{\infty} T(x') I(x - x') dx' \equiv T(x) * I(x), \quad (2)$$

where  $T(x)$  is called the *line-spread function* of the system. Although  $T(x)$  characterizes the system independent of the inputs and outputs, the function  $T(x)$  can be measured by using as input a unit line impulse in space (the delta function, whose value is zero except at one value of  $x$ , and whose integral over all  $x$  is 1), and recording the value  $I'(x)$  at all output times. Hence the name line-spread function. It is assumed here that, on the screen, the  $y$  dependence of  $I$  and  $I'$  does not exist or has been averaged out. Characterizing a two-dimensional optical system with a one-dimensional test pattern such as a line is also permissible if the system is *isotropic*, i.e., the direction of the line does not matter.

The term "modulation transfer function" is used in conjunction with systems in one spatial dimension (as in Eq. 2, or for isotropic two-dimensional systems completely characterized by a line-spread function independent of direction. However, the term does not apply to full two-dimensional spatial systems (as in Eq. 1). Therefore, this tutorial will deal only with Eq. 2.

### 3-2. Defining the MTF using the Fourier Transform

As will be shown in this section, when a cosine wave is input into a shift-invariant spatial system, it results in an output that is a shifted and scaled (attenuated) replica of the input. For a system with a symmetric line-spread function (such as characterizes most optical systems), the spatial shift is zero, and the MTF is defined as the ratio of attenuation as a function of the spatial frequency of the input wave to the attenuation of dc (zero-frequency).

For one spatial dimension, a unit-amplitude cosine wave with spatial frequency  $f$  (perhaps in cycles per visual degree, or cycles per centimeter of screen width) is

$$\begin{aligned} I'_c(x) &= \int_{-\infty}^{\infty} T(x') \cos[2\pi f(x - x')] dx' \\ &= \cos(2\pi fx) \int_{-\infty}^{\infty} T(x') \cos(2\pi fx') dx' + \sin(2\pi fx) \int_{-\infty}^{\infty} T(x') \sin(2\pi fx') dx' \\ &\equiv A(f) \cos(2\pi fx) - B(f) \sin(2\pi fx) \\ &\equiv |M(f)| \cos(2\pi fx - \mathbf{f}). \end{aligned} \quad (3)$$

In the third line of Eq. (3),



$$A(f) = \int_{-\infty}^{\infty} T(x') \cos(2\pi f x') dx' \quad (4)$$

and

$$B(f) = - \int_{-\infty}^{\infty} T(x') \sin(2\pi f x') dx' \quad (5)$$

are the real and imaginary parts of the Fourier transform of  $T(x)$  (see Bracewell, 1978). In full, this Fourier transform is given by

$$\begin{aligned} M(f) &= A(f) + j B(f) \\ &= \int_{-\infty}^{\infty} T(x') \exp(-j 2\pi f x') dx' \end{aligned} \quad (6)$$

where  $j = \sqrt{-1}$ . In the fourth line of Eq. (3),

$$|M(f)| = [A(f)^2 + B(f)^2]^{1/2} \quad (7)$$

is the modulus of  $M(f)$ , and

$$f = \arctan[B(f)/A(f)] \quad (8)$$

is the phase of the Fourier transform.

Equations (3)-(8) show that a shift-invariant linear system incurs a very simple transformation on an input cosine (or sine) wave: the output is an attenuated, phase-shifted replica of the input. The attenuation factor is given by  $|M(f)|$ , and the phase shift (in radians) is given by  $f$ .

In general, the function  $M(f)$  is called the *optical transfer function* of the system whose line-spread function is  $T(x)$ . However, if  $T(x)$  is symmetric [that is, if  $T(x) = T(-x)$  for all  $x$ ], then  $B(f) = 0$ ,  $M(f) = A(f)$  is a real function, and  $M(f)/M(0)$  is in that event called the *modulation transfer function* (MTF) of the spatial system. This particular usage—for the optical domain, and in particular to characterize lenses and human visual sensitivity—is documented by Cornsweet (1970) and by Wandell (1995). It should be appreciated that the symmetry of  $T(x)$  is a good assumption for a flat-panel display, so this restriction does not impair the usefulness of the MTF.

The derivation of the term "modulation transfer function" becomes clear in the optical context when one remembers that light cannot have negative intensity, hence one actually measures an optical system with the fully modulated cosine wave  $1 + \cos(2\pi f x)$  rather than with  $\cos(2\pi f x)$ . The output from this waveform is  $M(0)[1 + m \cos(2\pi f x)]$ , where  $m$  is the modulation depth of the waveform associated with frequency  $f$ . The factor  $m$  is, in fact, the MTF  $M(f)/M(0)$  evaluated at frequency  $f$ .

### 3-3. Useful properties of the MTF

As can be seen from Section 3.2, in one spatial dimension with a symmetric line-spread function, the MTF is the (real) Fourier transform of the line-spread function, normalized so the dc value is 1. In the Fourier domain, Eqs. (1) and (2) become particularly simple, due to the *convolution theorem* (see Bracewell, 1978):

$$\text{If } I'(t) = T(t) * I(t), \text{ then } I'(f) = T(f)I(f). \quad (9)$$

Here,  $I(f)$ ,  $T(f)$ , and  $I'(f)$  the respective Fourier transforms of  $I(t)$ ,  $T(t)$ , and  $I'(t)$ . Hence, in the Fourier-transform domain, a convolution between two functions becomes represented as a simple multiplication, frequency-by-frequency. In performing digital simulations of shift-invariant linear systems (optical or electrical), the convolution theorem becomes especially useful for two reasons:

- (a) There may be reason to perform multiple convolutions, which are expensive computationally; and
- (b) There is a method of performing the Fourier transform that is very efficient: The Fast Fourier Transform, developed by Cooley and Tukey in 1965 (see Bracewell, 1978).

These rather formal considerations are closely related to an informational advantage of the MTF over the grille contrast function (described in Section 2). To understand that advantage, it is helpful first to realize that the MTF and the grille-contrast function are measured the same way but using different input patterns: each point of the



MTF is a Michelson contrast, this time measured using fully modulated *sine*-wave inputs instead of square-wave inputs. To see this, imagine a fully modulated input sine wave

$$I(x) = A[1 + \cos(2\pi fx)]. \quad (10)$$

Using the property that sine waves are at most scaled by a linear, shift-invariant system with a symmetric line-spread function, we can now write the following expression for the output sine wave:

$$L(x) = A[a + b \cos(2\pi fx)]. \quad (11)$$

The Michelson contrast of this output function is then  $(L_{\max} - L_{\min})/(L_{\max} + L_{\min})$ , which in this case is

$$C_m = 2b/(2a) = b/a. \quad (12)$$

But the MTF of the system is the ratio of the Fourier transform of Eq. (11) at frequency  $f$ , divided by the Fourier transform of Eq. (11) at frequency 0. The numerator is  $Ab/2$ , and the denominator is the mean of  $L(x)$ , which is simply  $Aa$ . The ratio of numerator and denominator is just  $b/(2a) = C_m/2$ . This shows how the MTF is composed of a set of (half-scaled) Michelson-contrast measurements on input patterns that are fully modulated sine waves.

#### 4. COMPARATIVE APPLICABILITY OF GRILLE CONTRAST AND MTF

From Sections 2 and 3, it can be seen that, although the MTF and the grille contrast function have much in common, there are differences that seem to confer an informational advantage to the MTF. Given the spatial frequency of an input sine wave and the Michelson contrast of the output wave, one knows the shape of the output wave (it is another sine wave). A series of such contrast measurements at various spatial frequencies is therefore enough to predict the response to any input, so long as the assumptions in Sections 1 and 3 are satisfied. However, the grille contrast for a square-wave input pattern does not convey all the information about the output distortions of arbitrary input patterns.

The apparent informational advantage of the MTF over the grille contrast function is largely illusory in real-world applications, because the assumptions of shift-invariance, and even of linearity, do not apply to real displays. For example, the spatial output spread of an input line varies from place to place on a display screen, contrary to the assumption of shift-invariance. Because the main effect of input-to-output spreading occurs at high spatial frequencies, one could imagine measuring local parts of the screen with sine waves to effect a sort of "local MTF" characterization, complete with its power to predict contrast loss for arbitrary patterns. However, there would still remain the problem that the output line shape (e.g., the CRT beam shape) is highly nonlinear in peak input (e.g., the CRT beam current). This is quite apart from the gamma nonlinearity, which is presumed compensated on the input. Because the input sine wave has a large dynamic range (from black to white), one cannot hope to achieve even approximate linearity for an MTF interpretation.

Given these unpleasant facts of the real world, the apparent advantage of the MTF must bow to the more relevant advantage of the grille-contrast function: ease and repeatability of measurement. Because grille contrast measurements reveal contrast losses only at the highest spatial frequencies (at which sine waves are represented as approximate square waves anyway), the grille-contrast function might be roughly imagined to be as close as one could get to an MTF. However, the rough analogy should not blind one to the essential nonlinearity of the system one is measuring.

In summary, the grille-contrast function is to be recommended over the MTF for display measurement, partly because the measurements are more easily and repeatably performed, and partly because there is less tendency to import linear-system concepts where they do not belong.

#### 5. EFFECTS OF VIEWING ENVIRONMENTS ON CONTRAST FUNCTIONS

Contrasts on a displayed image in a dark room will always be greater than that in an environment with ambient lighting. This is so because veiling reflection from the ambient increases the minimum light levels from the image in greater proportion than it increases the maximum light levels from that same image. Accordingly, ambient light will decrease the components of the MTF (and also of the grille-contrast function) at nonzero spatial frequencies.

On the other hand, if there are internal reflections within the display unit itself, then the Michelson contrast with a bright screen image might not reach 100 % even in a dark room. For example, the light from a bright pixel could be reflected from one of the internal interfaces within the display and the reflected light could



illuminate the adjacent pixel, thus reducing contrast. The worst case is encountered in a well-lighted area or out of doors; in these cases, the perceived brightness of an unlit pixel case could appear quite bright. Not only do internal reflections contribute to the loss in contrast, but light scattered from a LCD layer, or from other internal components will also reduce the maximum contrast available in an operation environment. The reduction in contrast will be a function of spatial frequency, with the higher spatial frequencies likely to be affected the greatest.

## 6. GENERALIZATION TO TWO DIMENSIONS FORCED BY PIXEL GEOMETRIES

In a typical digital flat-panel display, neither the MTF nor the grille contrast function may be the same in different directions. If the pixels are non-square, these functions will be different in the horizontal and vertical directions. A still different contrast function will be measured when the spatial-frequency vector is oriented parallel to the diagonal of the image (even when the pixels are square). Thus, for a full characterization of the performance of a panel, an entire two-dimensional contrast function will be needed.

### References for this MTF tutorial

- [1] R. N. Bracewell (1978), *The Fourier Transform and its Applications*. Second Ed. New York: McGraw-Hill.
- [2] J. W. Cooley and J. W. Tukey (1965), *Math. Comput.* **19**, 297-301.
- [3] T. Cornsweet (1970), *Visual Perception*, Academic Press, pp. 312-330.
- [4] Electronic Industries Association (EIA, 1990). MTF Test Method for Monochrome CRT Display Systems, TEPAC Publication TEP105-17.
- [5] B. A. Wandell (1995), *Foundations of Vision*. Sunderland, MA: Sinauer; Chapter 2.
- [6] R. M. Boynton (1966), Vision, in Sidowski, J. B. (Ed.), *Experimental Methods and Instrumentation in Psychology*. McGraw-Hill, 1966.

## A221 STATEMENTS OF UNCERTAINTY

**Purpose:** We attempt to familiarize you with the most recent vocabulary for describing the estimate of uncertainty in a measurement result.

Suppose we purchase a luminance meter for which the specifications state a  $\pm 4\%$  “accuracy” with a “precision” of  $\pm 0.4\%$ . What do these terms mean? Is there a better way to express the uncertainties? There have been many terms used to describe measurement uncertainties: accuracy, inaccuracy, precision, imprecision, repeatability, reproducibility, variability, error, systematic error, random error, uncertainty, etc. All of these terms have been used in so many different ways that there has been a need to develop a precise terminology to deal with measurement uncertainties. Here we review some of the currently acceptable ways to describe measurement uncertainty, and we will do this using the example of photometric measurements. For a fuller discussion, see, for example, Barry N. Taylor and Chris E. Kuyatt, *Guidelines for Evaluating and Expressing the Uncertainty of NIST Measurement Results*, NIST Technical Note 1297, 1994 Edition—this reference is based on the ISO *Guide to the Expression of Uncertainty in Measurement* (International Organization for Standardization), 1995. There is also an ANSI publication covering this material: ANSI/NCSL Z540-2-1997 *U.S. Guide to the Expression of Uncertainty in Measurement*, (American National Standards Institute/National Conference of Standards Laboratories), first edition, October 9, 1997. Also see the *International Vocabulary of Basic and General Terms in Metrology*, a joint publication from BIPM, IEC, IFCC, ISO, IUPAC, IUPAP, OIML (1993).

Consider a circular aperture light source with absolutely uniform luminance over the disc of light (this could be closely approximated using a large, well-designed integrating sphere with a small circular exit port and having a 99 % reflectance interior, for example). The specific quantity of interest subject to measurement is called the **measurand**, and in this case it is the luminance of the light source. Let’s assume that its luminance is exactly  $L_0$ , i.e., the “true value” of the luminance is  $L_0$ . This “true value,” which, in general, is unknown and unknowable, is the **value of the measurand**. The value of the measurand is the result we would obtain if everything were perfect—if the measurand were perfectly defined in the context of its use, and if a perfect instrument were used to determine its value (obviously such an instrument does not exist). What we are trying to do with our real laboratory instrumentation is to obtain a result that is as close as possible to the value of the measurand, and we want to know how comfortable we can be with that result, which is the purpose of the uncertainty statement.



Be aware of the difference between the error in a measurement and the uncertainty of a measurement. When we make a measurement there is an unknown and unknowable error and an uncertainty associated with the measurement. The error is how close the measurement result is to the value of the measurand, which we never know. The uncertainty refers to how unsure we are of the value of the measurand based on our measurement. Thus, we could accidentally have a very small error in our measurement result but yet have a large uncertainty associated with it. How do we establish the uncertainty? In what follows we will speak of quantities and relative quantities—like uncertainty and relative uncertainty. If we said the uncertainty in a 1 m measuring stick is 1 mm, we could also express the uncertainty as a relative uncertainty of 0.1 %, i.e., “relative” refers to the fractional amount of the quantity most often expressed as a percent.

With our luminance-meter example, the manufacturer claims an “accuracy” of  $\pm 4\%$  with “precision” of  $\pm 0.4\%$ . How do we correctly interpret this? The claim most likely means: The luminance meter has a **relative uncertainty of measurement** at some level of confidence (e.g., 95 %) of  $\pm 2\%$  with a **relative reproducibility** of  $\pm 0.2\%$  over a 24 hour period, for example. The reproducibility suggests closeness of agreement between measurements made under different conditions, such as a few hours between measurements, using different operators, at different temperatures, etc. If the manufacturer meant that the  $\pm 0.2\%$  applies when one makes repeated measurements over a short time trying to keep everything the same, the claim would be changed to state that the meter has a **relative repeatability** of  $\pm 0.2\%$  over a ten-minute period, for example. With uncertainty statements there is usually a period of time over which the uncertainty estimate is regarded as reliable, for example, one month, six months, one year, etc., but we will ignore that for our purposes of illustration. The reported uncertainty of measurement (“accuracy”) for the manufacturer’s instrument should already include the reproducibility and/or the repeatability in its evaluation.

In the discussions here we are assuming that the results of the measurement of the measurand has a probability density function associated with it having a mean and a standard deviation that could only be obtained through an infinite number of measurements. The probability density function, its mean, and its standard deviation cannot be strictly known; they can only be estimated through repeated measurements. Thus, when we speak of a mean or a standard deviation from measurement results, we are always referring to an *estimate* of the mean and standard deviation of the probability density function. Often the probability density function is normal—also called Gaussian—but that is not necessarily always the case. See the references for further information.

Any measurement can have several contributions to its uncertainty. Each **component of uncertainty**  $i$  can be estimated by a standard deviation called the **standard uncertainty**  $u_i$  (equal to the square root of the estimated variance). Now, in general, there are two categories identified: **Type A evaluation of uncertainty** that refers to uncertainties that are evaluated by statistical means, and **Type B evaluation of uncertainty** that refers to uncertainties that are evaluated by other means. Type A uncertainty evaluation could be the standard deviation of the mean of a series of repeated observations, but it is not limited to such an evaluation. Type B uncertainty evaluation is based on scientific judgment accounting for all available relevant information, which can include manufacturer’s specifications, uncertainty in the calibration of the instrument, experience with the instrumentation, and so forth.

It may not be very obvious why there is a need for this new terminology. Let’s look at how we talked about uncertainty in the past: We used to consider that there were two types of measurement uncertainties. We called them “random uncertainties” and “systematic uncertainties,” a rather careless shorthand way of saying uncertainties arising from random effects (manifested by small random variations in the measurement result) and uncertainties arising from systematic effects (such as the calibration uncertainty of the instrument). With our above luminance-meter example, the “random uncertainty” would be obtained by making repeated measurements and calculating the standard deviation of those measurements—we would now call this the repeatability.

In the context of our document, we can illustrate the inadequacy of the terms “random uncertainty” and “systematic uncertainty.” Suppose we measure the luminance of a display as a function of voltage or gray-scale level, and we want to determine the best value of  $g$  using the model  $L = L_b + aV^g$  (this is called the gamma of the display, see Section 302-5). We might use a nonlinear least squares technique to obtain  $g$  and an estimation of its standard deviation  $s_g$ . That is not a “random uncertainty,” nor is it a “systematic uncertainty”; rather, it is a Type A uncertainty since it was derived from a statistical analysis of observations. In our earlier example of making a measurement of the luminance of the source, the Type A uncertainty is equivalent to the component of uncertainty arising from the observed random variations of our repeated observations (which in the past we would have called “random uncertainty”). For that same example, the Type B uncertainty is equivalent to the component



of uncertainty arising from the quoted 2 % “accuracy” of the instrument (which in the past we would have called “systematic uncertainty”). However, Type A and Type B are not synonyms for “random” and “systematic.”

The **combined standard uncertainty** is the “root-sum-of-squares” (square root of the sum-of-the-squares, or RSS) of all the component uncertainties whether arising from a Type A evaluation or a Type B evaluation,

$$u = \sqrt{\sum u_i^2}$$

Finally, the **expanded uncertainty** is a **coverage factor**  $k$  times the combined standard uncertainty,

or  $U = ku$ . The coverage factor increases the estimate of the uncertainty to reflect a higher probability that the unknown value of the measurand lies within the measurement result plus and minus the expanded uncertainty. Often, in the past, one would perhaps use  $k = 2$  and say that the measurement had a “two-sigma” uncertainty. We would now say that the measurement has an expanded uncertainty of such-and-such with a coverage factor of  $k = 2$ . The coverage factor is not limited to being two, but it will depend upon the experiment.

Now, consider the above luminance meter for which the specifications state an “accuracy” of  $\pm 4\%$  with a “precision” of  $\pm 0.4\%$ . Suppose we are going to use it to measure the luminance of the exit port of an integrating sphere. Unless more detailed information were provided about the uncertainty statement, we would have to contact the manufacturer in order to know how the uncertainty estimate was established. We will assume that the manufacturer has already incorporated a coverage factor  $k = 2$  in reporting the uncertainty of measurement of the instrument. We will assume that this represents a 95 % confidence. (The manufacturer should have reported his uncertainty estimate by saying something such as: The instrument has a relative expanded uncertainty of 2 % with a coverage factor of two ( $k = 2$ ) and a repeatability of 0.4 % over a ten-minute period.) Since the uncertainty is expressed in percent, we will call this relative expanded uncertainty  $U_m/L = 4\%$ , where  $L$  is the result of any luminance measurement. The instrument measurement uncertainty is one of the components of uncertainty that will be included in our estimating the uncertainty of our luminance measurement; it is a type B uncertainty estimate.

Suppose we now obtain a series of ten measurement results of the exit port luminance and find the mean to be  $L = 2314 \text{ cd/m}^2$  with a standard deviation of  $u_r = 42 \text{ cd/m}^2$  ( $u_r$  is the repeatability of the measurement of the exit port luminance, not of the instrument);  $u_r$  is a type A uncertainty estimate. If  $u_r$  were only due to the repeatability of the instrument it would be approximately  $9 \text{ cd/m}^2$ . The additional uncertainty must come from instabilities in the light source or in our method of making the measurement; e.g., if we were using a hand-held luminance meter, the additional uncertainty might come from our sloppy (and random) locating of our measurement at the center of a nonuniform exit port. Suppose that we are unaware of any other source of uncertainty in the measurement. We would have two components of uncertainty, the measurement uncertainty of the instrument and the repeatability uncertainty of the measurement of the exit port.

The expanded uncertainty with a coverage factor of two expresses a 95 % confidence that the measurand is within the expanded uncertainty of the measurement result. Our repeatability of the luminance of the exit port  $u_r$  is a single standard deviation representing a confidence of 68 %. What instrument uncertainty would we use, the expanded uncertainty (95 % confidence) or remove the coverage factor from the expanded uncertainty and use the combined standard uncertainty  $u_m = U_m/2$  (68 % confidence)? It will depend upon our experience with the instrumentation, how stable it has proved to be, when it was calibrated, etc. The combined standard uncertainty will be a RSS of the two components. The expanded uncertainty will be a coverage factor times the combined standard uncertainty.

**Table 1.** Uncertainty estimation of exit port luminance measurement example.

CSU = combined standard uncertainty, EUCEF2 = expanded uncertainty with coverage factor of two ( $k = 2$ )				
(A) = type A (B) = type B	Instrument is stable, reliable, recently calibrated: May want to use $u_m$ .		No history of instrument reliability and stability, not recently calibrated: Use $U_m$ .	
$L = 2314 \text{ cd/m}^2$	$u = \text{CSU}$	$u/L = \text{Relative CSU}$	$u = \text{CSU}$	$u/L = \text{Relative CSU}$
$u_r = 42 \text{ cd/m}^2$ (A)	$u = \sqrt{u_m^2 + u_r^2}$	$\frac{u}{L} = \sqrt{\left(\frac{u_m}{L}\right)^2 + \left(\frac{u_r}{L}\right)^2}$	$u = \sqrt{U_m^2 + u_r^2}$	$\frac{u}{L} = \sqrt{\left(\frac{U_m}{L}\right)^2 + \left(\frac{u_r}{L}\right)^2}$
$U_m/L = 4\%$ (B)	$= 62 \text{ cd/m}^2$	$= 2.7\%$	$= 102 \text{ cd/m}^2$	$= 4.4\%$
$U_m = 93 \text{ cd/m}^2$ (B)	$U = \text{EUCEF2}$	$U/L = \text{Relative EUCEF2}$	$U = \text{EUCEF2}$	$U/L = \text{Relative EUCEF2}$
$u_m/L = U_m/2L = 2\%$ (B)				
$u_m = 46 \text{ cd/m}^2$ (B)	$= 124 \text{ cd/m}^2$	$= 5.4\%$	$= 204 \text{ cd/m}^2$	$= 8.8\%$

DISCUSSIONS



However you determine the uncertainty of your measurement, it is important that you make that determination clear in the presentation of your results. Whether you used the manufacturer's combined standard uncertainty ( $u_m = U_m/2$ ) or expanded uncertainty ( $U_m$ ) in your calculation of the RSS combined standard uncertainty of your measurement, simply make it sufficiently clear so that any reader will be able to understand the origin of your uncertainty statement. Also, when reporting the uncertainty most will assume that you are reporting the expanded uncertainty with a  $k = 2$  coverage factor. If that is not the case, it should be clearly stated.

Perhaps after reading this you have the opinion that we have simply made life difficult by attaching new terms to things already familiar. That is understandable; it may seem to be overkill. However, these terms have acquired an international acceptance and are precisely defined. What they replace have been too carelessly used and do not allow for the correct uncertainty treatment of all kinds of measurements, some of which can be exceptionally complicated, as with the measurement of fundamental constants. This terminology is being used throughout the world so that everybody will understand precisely what is being said about uncertainty.

## A222 PROCEDURE FOR VERIFYING DIGITALLY DRIVEN COLOR MONITORS

A procedure is described to verify color transfer between video display units (VDUs) through a digital medium. In its simplest form, verification involves measuring the CIE  $XYZ$  tristimulus values of 9 full-screen test colors on a VDU and comparing them with published target values. To accommodate gamut mismatches, the test colors are derived from Color-Rendering-Index reflectances—which are desaturated enough to fit in most any device's color gamut. To accommodate white-point differences, the test colors are adapted to each VDU's white point using an illuminant-reflectance model. To produce these colors and to use them for verification, the following procedure is recommended.

**A. OFF-LINE PROCESSING** (purely numerical, requiring no VDUs and to be performed once for all time)

**Step 0.** Compute tristimulus values of color-rendering-index (CRI) reflectances as if illuminated by daylight-eigenvector spectra. This computation uses: (a) The 1931 CIE  $XYZ$  color-matching functions  $x_j(I_k)$ , where  $j = 1$  for X, 2 for Y, 3 for Z, and  $I_k$  assumes the 31 values from 400 to 700 nm at 10-nm increments [Ref. 3; also Ref. 4, Table 2(3.3.8)]; (b) the principal-component spectra of daylight  $S_0(I_k)$ ,  $S_1(I_k)$ , and  $S_2(I_k)$  [Ref. 3; also Ref. 4, Table V(3.3.4)]; and (c) reflectance spectra  $r_i(I_k)$  of the first eight Munsell reflectances used to compute the Color Rendering Index (Ref. 1; also Ref. 2, Table 6.7). Given these ingredients, compute the tristimulus values of each CRI reflectance plus white [ $r_0(I_k) = 1$ ] under the three daylight principal-component spectra (eigenvectors). The result is a set of 81 values. Nine of these values define a  $3 \times 3$  matrix **A** whose  $mj$  element is the  $j$ 'th tristimulus value of the  $m$ 'th daylight eigenvector:

$$A_{mj} = \sum_{k=1}^{31} S_m(I_k) x_j(I_k). \quad (1)$$

The other 72 of these values comprise a  $3 \times 3 \times 8$  array **B** whose  $mji$  element is the  $j$ 'th tristimulus value of the  $i$ 'th CRI reflectance times the  $m$ 'th daylight eigenvector:

$$B_{mji} = \sum_{k=1}^{31} r_i(I_k) S_m(I_k) x_j(I_k). \quad (2)$$

The 81 numbers comprising arrays **A** and **B** are circulated with the digital standard for use in computing target tristimulus values for each device. (Note: Values for the CRI reflectances show small differences between Refs. 1 and 2, presumably due to re-measurement of the standard Munsell reflectances. In the present worked example, the values in Ref. 2 are used because they are more accessible. However, in Table 1 the CIE values are re-tabulated and recommended in preference to those of Ref. 1.)

**B. TEST-COLOR PREPARATION USING STANDARD VDU** (to be done each time a new digital communication protocol is implemented)



**Step 1.** Select a standard VDU and measure its white-point tristimulus values. These values are the 1931 XYZ values  $\mathbf{X}_{nR} = (X_{nR}, Y_{nR}, Z_{nR})$ . At present, CRTs are well understood and readily used in this context.

**Step 2.** Compute CIELUV values of CRI reflectances under a model light. The model-light spectrum is the linear combination of daylight eigenvectors that has the same tristimulus values as the standard-VDU white point. First, compute coefficients  $(a_0, a_1, a_2) = \mathbf{a}$  for the linear combination of daylight eigenvectors that produces tristimulus values  $\mathbf{X}_{nR}$ :

$$\mathbf{a} = \mathbf{X}_{nR} \mathbf{A}^{-1}, \quad (3)$$

where  $\mathbf{A}$  was computed in Step 0. Then, compute the target tristimulus values  $\mathbf{X}_{iR} = (X_{iR}, Y_{iR}, Z_{iR})$  of the eight CRI-based test patches  $i$  under the model light:

$$(X_{iR}, Y_{iR}, Z_{iR}) = \sum_{m=0}^2 a_m (B_{m1i}, B_{m2i}, B_{m3i}), \quad (4)$$

where  $B_{mji}$  were computed in Step 0. Finally, compute target CIELUV coordinates  $(L^*_{iR}, u^*_{iR}, v^*_{iR})$  from  $\mathbf{X}_{iR}$  and white point  $\mathbf{X}_{nR}$  (see Section A201). The choice of CIELUV is based on its historical use by the display industry.

**Step 3.** Select digital colors (that will be presented to all test devices). Arrange digital inputs to the standard device that result in measured CIELUV values  $(L^*_{iR'}, u^*_{iR'}, v^*_{iR'})$  that match the target values  $(L^*_{iR}, u^*_{iR}, v^*_{iR})$  as closely as possible. Use the white point  $\mathbf{X}_{nR}$ . The criterion of closeness is that each  $\Delta E$  value should be less than 3 — the minimum perceptible color difference for colors that are not spatially next to each other.

*Note:* Step 3 is difficult because it involves iterative adjustment of the digital values until the correct tristimulus values are obtained. Fortunately, Step 3 needs to be done only for the standard VDU. One way of performing Step 3 is to use an accurate model of the standard VDU to make a good first estimate of the required digital values for each test-pattern color, and then to refine this estimate by experiment.

**C. COLOR VERIFICATION OF TEST-VDU** (to be performed for each test VDU, for each new communication protocol, and as needed for maintenance)

**Step 4.** Measure XYZ values  $\mathbf{X}_{nT} = (X_{nT}, Y_{nT}, Z_{nT})$  of the test-VDU white point.

**Step 5.** Compute CIELUV values of CRI colors under model test-light. The test light is the linear combination of daylight eigenvectors that has the same tristimulus values as the test-VDU white point. First, compute coefficients  $(b_0, b_1, b_2) = \mathbf{b}$  for the linear combination of daylight eigenvectors that has tristimulus values  $\mathbf{X}_{nT}$ :

$$\mathbf{b} = \mathbf{X}_{nT} \mathbf{A}^{-1}, \quad (5)$$

where  $\mathbf{A}$  was computed in Step 0. Then, compute the target tristimulus values  $\mathbf{X}_{iT} = (X_{iT}, Y_{iT}, Z_{iT})$  of the eight CRI-based test patches  $i$  under the model test light:

$$(X_{iT}, Y_{iT}, Z_{iT}) = \sum_{m=0}^2 b_m (B_{m1i}, B_{m2i}, B_{m3i}), \quad (6)$$

where  $B_{mji}$  were computed in Step 0. Finally, compute CRI target CIELUV coordinates from  $\mathbf{X}_{iT}$  and white point  $\mathbf{X}_{nT}$ .

**Step 6.** Measure test-pattern colors on the test device. Let the digital values derived from the standard VDU (step 3) drive the test VDU, measure the XYZ tristimulus values  $(X'_{iT}, Y'_{iT}, Z'_{iT})$  of these 8 colors, and convert them to CIELUV using white point  $\mathbf{X}_{nT}$ , for comparison with the target values in Step 5.

**Step 7.** Compute CIELUV  $\Delta E$  values for the measured test colors relative to the target values. Each  $\Delta E$  value should be less than 10 for the color-transfer to be called successful. The value 10 comes from the observed variations of CIELUV coordinates across VDU screens.

To illustrate the use of this method, consider as a standard pattern generator a CRT, and as a test VDU a laptop computer (LCD). Eight-bit digital values (R', G', B') are used to drive both displays. Because there is no



color-management system to adjust for the display differences, the color-reproduction results are expected to be unsatisfactory.

For the standard CRT, an NTSC-based device model was used in Step 3 to produce a first estimate of digital values that produce the target tristimulus values described in Step 2. Once the first estimates are made, they were refined based on measurements to provide  $X$ ,  $Y$ ,  $Z$  values that were as close as possible to the values for the targets.

**Table 1. Results of Verification-Procedure Reduction to Practice.**

CRI	COMPUTED		MEASURED		$\Delta E$	Display
	$x$	$y$	$x$	$y$		
1	0.3434	0.3190	0.3415	0.3219	2.28	STANDARD Generator CRT
2	0.3560	0.3903	0.3552	0.3909	0.656	
3	0.3485	0.4646	0.3485	0.4642	0.145	
4	0.2646	0.3928	0.2643	0.3913	0.637	
5	0.2378	0.2930	0.2382	0.2923	0.558	
6	0.2220	0.2301	0.2218	0.2304	0.257	
7	0.2581	0.2259	0.2588	0.2267	0.628	
8	0.2934	0.2473	0.2918	0.2458	1.18	
1	0.3744	0.3486	0.3336	0.3523	68.7	TEST Laptop Computer LCD
2	0.3817	0.4130	0.3673	0.3351	34.4	
3	0.3682	0.4812	0.3810	0.3753	49.3	
4	0.2852	0.4221	0.3447	0.4410	29.7	
5	0.2588	0.3292	0.2677	0.4231	34.0	
6	0.2423	0.2652	0.2275	0.2993	26.0	
7	0.2856	0.2612	0.2079	0.2315	39.0	
8	0.3256	0.2812	0.2668	0.2452	33.6	

The table summarizes the results of the procedure. Each  $\Delta E$  value in the table compares computed and measured colors in a single device. It can be seen that the  $\Delta E$  values are acceptably small for the standard VDU, but not for the test VDU. Further work will determine whether the 10-unit criterion is too stringent for realistic use, and to what extent color-management systems can ameliorate the results of inter-device color transition as evaluated by the present procedure. See the Table A222 in the Appendix A500 for the spectra of the CRI reflectances, the daylight eigenvectors, and the color-matching functions.

The similarities and differences should be noted between the present procedure and the proposed SMPTE standard 303M (See Ref. 5). In common with the present procedure, the SMPTE standard derives target tristimulus values using an illuminant-reflectance model. However, whereas we describe a method that accommodates to all white points, the SMPTE standard pre-computes tristimulus values only for three white points (D65, D55, and 3100K). Also, the SMPTE standard uses 24 reflectances (some of them highly chromatic) instead of eight, and therefore is not tuned to testing digital protocols because of the possibility of out-of-gamut colors.

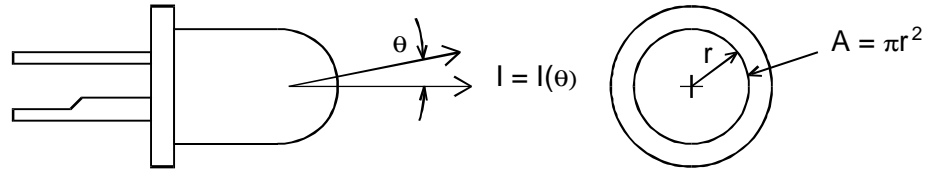
### References

- [1] Commission Internationale de l'Eclairage (CIE), Method of Measuring and Specifying Colour Rendering Properties of Light Sources (Second Edition), *Publication CIE 13.2*, Bureau Central de la CIE, 1974.
- [2] G. Wyszecki and W. S. Stiles, *Color Science*, First ed., Wiley, 1967.
- [3] Commission Internationale de l'Eclairage (CIE), Colorimetry (Second Edition), *Publication CIE 15.2*, Bureau Central de la CIE, 1986.
- [4] G. Wyszecki and W. S. Stiles, *Color Science*, 2nd ed., Wiley, 1982.
- [5] Proposed SMPTE Standard for Television--Color Reference Pattern, *J. SMPTE*, September 1997, pp. 643-649.



**A223 LUMINANCE OF AN LED**

**Problem:** Given an ideal LED with radius  $r = 3$  mm and rated at 300 mcd at 20 mA (15 cd/A), what is its luminance if the current  $J = 20$  mA?



An ideal LED, in this case, is one that appears to have a uniform luminance distribution when you look at it along its axis (perpendicular to its base), i.e., the area  $A = \pi r^2 = 2.827 \times 10^{-5} \text{ m}^2$  appears to have a uniform brightness. (Many LEDs appear relatively uniform to the eye.) The LED is rated ( $R$ ) by a luminous intensity  $I$  produced by a certain current  $J$ :  $R = I/J = 15 \text{ cd/A}$ . The luminance of a uniform disk is related to the luminous intensity for long distances (see A210 for example) by  $I = LA$ . The luminance is then  $L = I/A$ , or in terms of the rating:

$$L = JR/A = 10\,610 \text{ cd/m}^2, \tag{1}$$

for a current of  $J = 20$  mA.

**A224 LUMINANCE OF LAMBERTIAN DISPLAY**

**Problem:** Determine an expression for the luminance of a Lambertian display in terms of its luminous flux  $F$  and luminous efficacy  $h$  given a power input  $P$ .

The luminous efficacy is given by the ratio of the luminous flux  $F$  output to the electrical power  $P$  input.

$$h = F/P. \quad [\text{lm/W}] \tag{1}$$

The luminous intensity of a Lambertian emitter is given by (see A206)

$$I = I_0 \cos q, \tag{2}$$

where  $q$  is the inclination angle and  $I_0$  is the luminous intensity in the normal direction,  $I_0 = LA$ . To get the luminous flux, we integrate the luminous intensity over the hemisphere; the element of flux in terms of an element of solid angle is  $dF = IdW$ , and using Eq. 2,

$$F = \int_{\text{hemisphere}} IdW = 2\pi LA \int_0^{\pi/2} \cos q \sin q \, dq = \pi LA \tag{3}$$

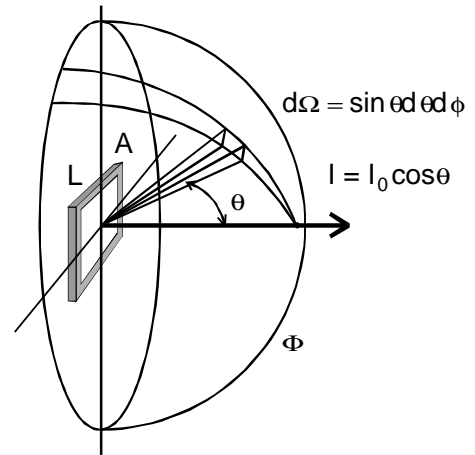
(where we used the substitution method with  $u = \sin q$ ). Therefore, the luminance in terms of the flux is

$$L = F/\pi A. \tag{4}$$

If we know the input power  $P$  and the luminous efficacy  $h$ , then from Eq. 1 we can write the luminance as

$$L = hP/\pi A. \tag{5}$$

For example, given a screen with area  $A = 400 \text{ mm} \times 300 \text{ mm}$  ( $H \times V$ ) =  $0.12 \text{ m}^2$ , if the luminous efficacy is  $h = 15 \text{ lm/W}$ , and the power input is  $P = 3 \text{ W}$ , then the flux is  $F = 45 \text{ lm}$ , and the luminance is  $L = 119 \text{ cd/m}^2$ .



DISCUSSIONS



## A225 GAIN OF A DISPLAY

**Abstract:** We define the gain of a display over a Lambertian emitter. **Problem:** How much brighter will a privacy display be that uniformly emits light in a cone of apex angle  $46^\circ$  than a Lambertian display, and what is its gain? Assume the display has an area of  $A = 400 \text{ mm} \times 300 \text{ mm}$ , and that the luminous flux from the display is  $F = 45 \text{ lm}$ .

The gain  $G$  of a display describes how much brighter a display would be as viewed from the perpendicular (normal) direction compared to a display with a Lambertian emission of light having the same luminous flux output. The gain is defined by:

$$G = \pi \frac{LA}{F}, \tag{1}$$

where  $L$  is the luminance of the display and  $A$  is the area of the emitting surface. The gain for a Lambertian emitter is one,  $G = 1$ .

From the previous problem (A224, Luminance of Lambertian Display), the luminous flux  $F$  from a Lambertian emitter is given by  $F = \pi LA$ , where  $L$  is the luminance of the display and  $A$  is the area of the emitting display surface. Then the ratio  $\pi LA/F = 1$  for a Lambertian emitter. If a display pumps out more light in the normal direction than would a Lambertian emitter the luminance will be greater than a Lambertian display for the same total luminous flux output:  $L = GF/\pi A$ .

Suppose we have two displays both with flux outputs of  $F = 45 \text{ lm}$ . One display is a Lambertian emitter, and the other display is constructed as a privacy display where all the light is emitted uniformly within a cone with apex angle of  $\alpha = 46^\circ$ . We want to determine how much brighter the privacy display will be than the Lambertian display, and what is the gain of the privacy display?

The display has an area of  $A = 0.12 \text{ m}^2$ . For the Lambertian display the luminance  $L$  is related to the flux  $F$  by  $F = \pi LA$ . Solving for the luminance, we find

$$L = F/\pi A = 119 \text{ cd/m}^2. \tag{2}$$

For an apex angle of  $\alpha$ , the maximum of  $q$  will be  $q = \alpha/2 = 23^\circ$ . We integrate the element of solid angle  $dW$  over the cone:

$$W = \int_0^{2\pi} d\phi \int_0^{\alpha/2} \sin q \, dq = 2\pi[1 - \cos(\alpha/2)]. \tag{3}$$

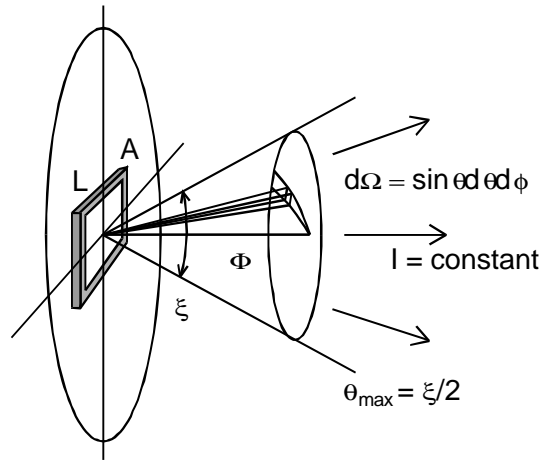
With the privacy display the luminous flux  $F'$  is given by  $F' = L'A$ , where  $L'$  is the luminance of the privacy display. The total flux from the privacy display is the same magnitude as the flux from the Lambertian display (so we don't need a prime here to distinguish it)  $F = F'W = 2\pi[1 - \cos(\alpha/2)]L'A$ . Solving for the luminance, we get

$$L' = F/2\pi[1 - \cos(\alpha/2)] A = L/2[1 - \cos(\alpha/2)] = 751 \text{ cd/m}^2, \text{ or } L'/L = 6.29. \tag{4}$$

That's a six-fold increase in the luminance, but to the eye  $\sqrt[3]{L'/L} = 1.85$  times as bright (see A209). The gain of the privacy display will be

$$G = \pi L'A / F = L'/L = 1/[1 - \cos(\alpha/2)] = 6.3. \tag{5}$$

Here, again,  $L'$  is the luminance of the privacy display, and  $L$  is the luminance of the Lambertian display with the same flux output.

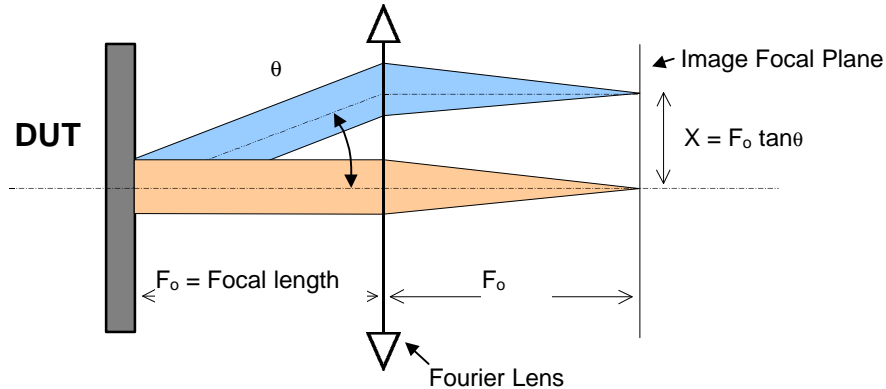


DISCUSSIONS



## A226 EQUIPMENT BASED ON FOURIER OPTICS

Optical-Fourier-transform light-measuring devices (OFT LMDs) provide angularly resolved measurements made with one spatially resolved exposure on an array detector. The basic principle of such equipment is the use of optical Fourier transform. An on-axis parallel beam of light reaching a lens will focus at a point in its image plane located at the focus of the lens. This is the basis of collimated optics as discussed in A219. An off-axis beam of incidence will also focus in that same plane (See figure 1).

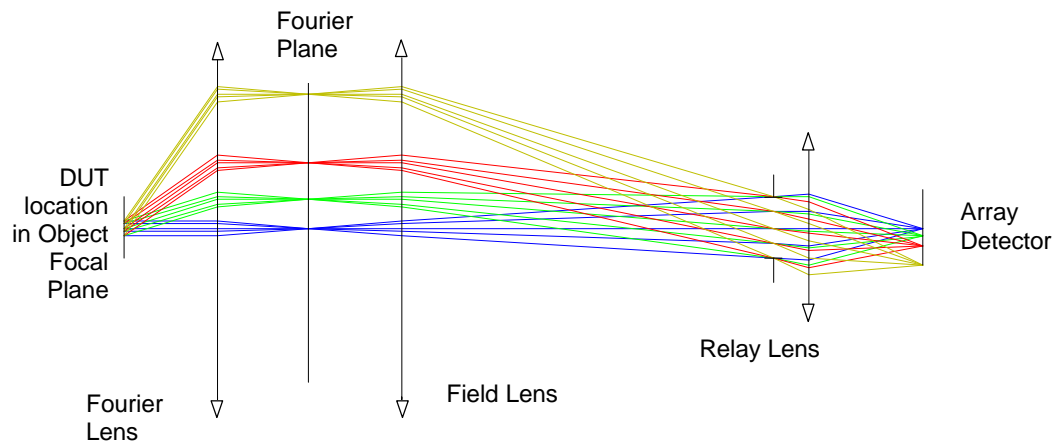


*Fig. 1. An optical Fourier transform lens system.*

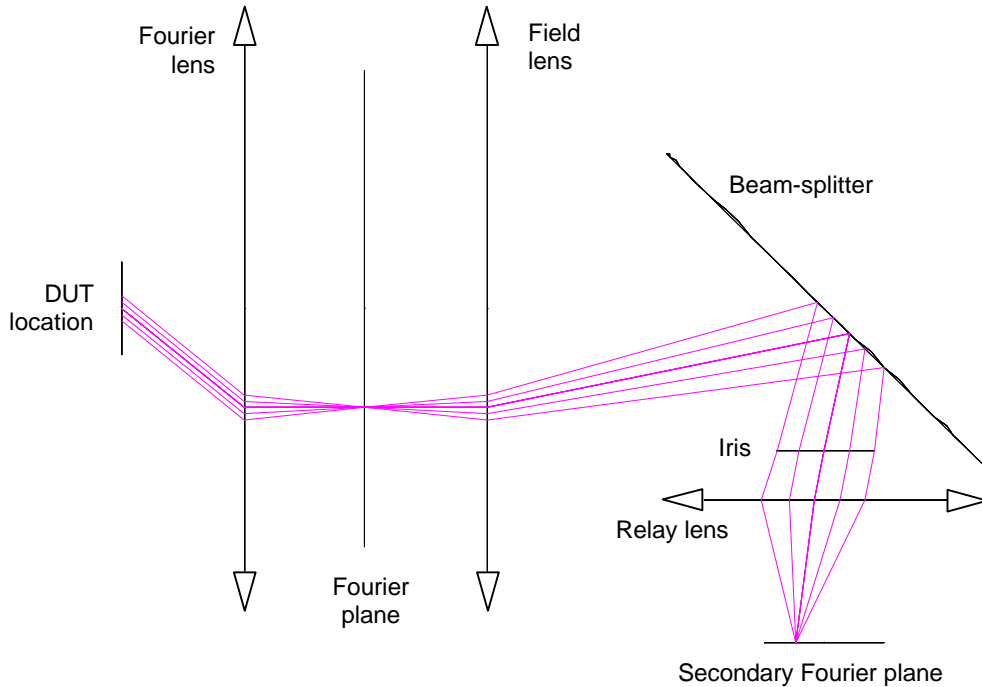
The relationship between the focus-point coordinate  $X$  and the incidence angle  $q$  is  $X = F_o \tan q$ . If an object is placed in the focal object plane, all the beams focusing in the focal image plane are originated from the same area. The image that is obtained in this plane is called the optical Fourier transform (OFT) of the object. In the case of FPDs, this image can easily be used for measuring any angle-dependant characteristics. It is usually collected by a relay lens and formed on a CCD detector for further analysis. The complete system usually contains (see Figure 2):

1. The Fourier lens
2. A field lens that is used to create an image of the object on an iris
3. An iris. By changing the iris size, the size of the measurement spot is changed. The usual spot size can range from  $100\mu\text{m}$  to more than 4 mm.
4. A relay lens that makes an image of the angular light distribution on an array sensor.
5. An array detector, usually a cooled CCD.

**Measuring Reflection:** Based on the principle of Figure 2, we combine angular light distribution measurement and illumination through the lenses. The principle is roughly shown on Figure 3. By using a point



*Fig. 2. Complete system design.*



**Fig. 3.** Angular resolution of luminance.

source in the secondary Fourier plane, a well-defined specular source can be obtained. By using a uniform lighting in the same plane, a diffuse illumination is produced with an acceptable uncertainty (less than  $\pm 10\%$  variations over the whole hemisphere).

**Working distance:** The ability to measure over a wide viewing angle requires a high numerical aperture (NA. = 0.985 for  $q$  up to  $80^\circ$ ), and is usually also associated with a short working distance. As can be deduced from Figure 1, the diameter of the front lens  $D$  can be directly related to  $q$  and the working distance  $W$  as follows:  $W = (D - S_0) / 2 \tan q$  where  $S_0$  is the maximum spot size. For practical and economical reasons ( $D - S_0$ ) is limited to roughly 25 mm to 30 mm. Consequently,  $W$  will be about 2 mm for  $q \leq 80^\circ$ —sufficient for measurement of conventional FPDs. Greater working distances can be allowed by decreasing the maximum incidence angle ( $q \leq 60^\circ$  allows for  $W$  about 7 mm). Short working distances may sometimes also allow measurements without a fully darkened room.

**Aperture and Angular resolution:** For conventional LMDs the numerical aperture (or subtended angle  $q_L$ ) of the optics limits the angular resolution (see Figure 1 of 301-2h). Given an LMD angular field-of-view (AFOV)  $q_F$ , light coming from a cone of subtense ( $q_L + q_F$ ) can reach the detector and measurement is an average of the display's characteristics over the solid angle  $2\pi[1 - \cos((q_L + q_F)/2)]$ . For OFT equipment the angular resolution of the system is limited only by the optical-parts quality and by the array sensor pitch. Resolution down to  $\pm 0.5^\circ$  is usually achieved. If requested, averaging the data over a given solid angle can reproduce the response of conventional LMDs.

**Field Of View:** For conventional LMDs and for a given measuring distance the AFOV selects the spot size (measurement area on the FPD, or FOV). The diameter of the measured spot is given by  $S_D = 2z \tan(q_F/2)$ , where  $z$  is the measuring distance. For OFT based equipment the spot size is adjusted internally by the way of an iris placed in the optical path (see Figure 2).

#### DIAGNOSTICS FOR SYSTEM QUALITY:

Quality assurance of an OFT device is similar to that of a conventional LMD. Indeed, an OFT device can be seen as many collimated-optics LMDs (as described in A219) working in parallel. Additions to A101, A106, A107 and A109 are discussed below

**Lens flare diagnostic:** As depicted in A101, lens flare and veiling glare can corrupt measurements through light that is reflected and diffused from optical elements inside the LMD (lenses, stops, baffles, etc.) or



from surrounding equipment. It must be kept in mind that even if a FPD is very dark when viewed perpendicularly, light emitted at other angles can be significantly higher (many decades if we integrate the luminance over the actual solid angle). In such situations, parasitic light reflected from the environment needs to be taken into account. As compared with a conventional LMD, an OFT LMD sees only a limited part of the FPD due to its screen proximity, and also is protected from reflection to the environment. However, lens flare remains a concern.

**Check for worst-case lens flare:** The best way to check lens flare is to use specially designed "targets" in front of the equipment. The simplest one is composed of a reflective (aluminum or chromium) spot on a transparent support. The diameter  $D_1$  of the spot is chosen large enough to include the measurement spot. If  $D_0$  is the spot size, we need to have  $D_1 > D_0 \cos q_{\max}$ .  $D_0$  is chosen significantly smaller than the usual spot (for example  $D_0 = 150 \mu\text{m}$  and  $D_1 = 1 \text{ mm}$ ). This target is then placed in front of a light source and the angular distribution of luminance on the reflective spot is measured. Integration over the whole solid angle can give the value of the "lens flare" flux on the sample, and will represent the worst-case lens flare effect.

Both diffuse light (the output of an integrating sphere) and collimated light can be used for this measurement. In the second case, the influence of input light direction can be checked. Measurement can be normalized to light input by measuring the source without inserting the target in front of it. This test is very similar to what is done to check dark-room conditions.

**Compensation for veiling glare:** The same procedure as described in A101 (Correcting for glare without a mask) can be used for OFT LMDs as for conventional LMDs.

**Linearity diagnostic:** Section A106 fully applies. Linearity will be checked for all angles at the same time by collecting the data at the output of the integrating sphere.

**Polarization diagnostic:** Section A107 fully applies. Choose an incidence angle according to the polarization factor of the polarizer. To choose this angle, use a collimated light source with a polarizer in front. The incidence angle of the light beam can then be changed to check the equipment from perpendicular to maximum incidence angle.

**Color measurement diagnostic:** As explained in Section A109, the best color diagnostic is to check the measurement uncertainty for monochromatic light. This gives an absolute way of checking color-coordinate uncertainty. As shown on Figure 4, place the OFT LMD in front of a diffuse monochromatic source of a desired wavelength, and check the system uncertainty (in  $x, y$  or  $u'v'$ ) for any desired viewing angle. It may be a good practice to make this measurement for each device or at least to have it provided by the manufacturer.

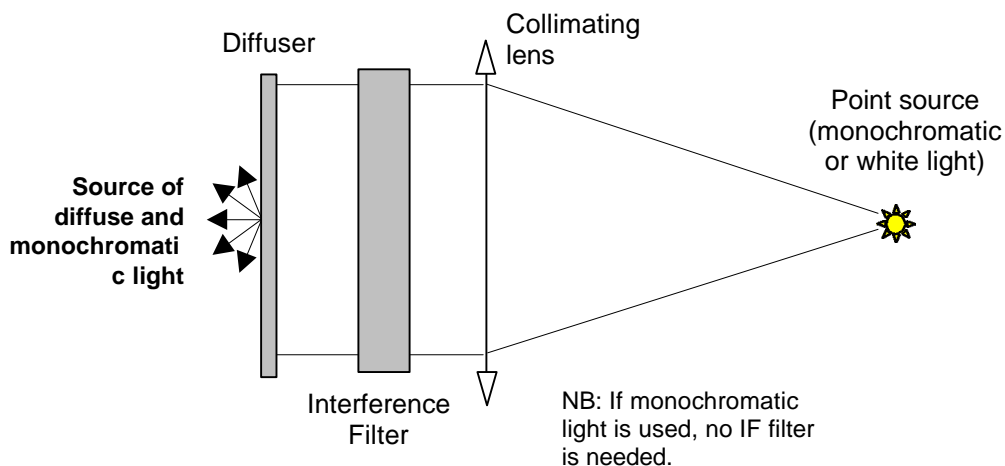


Fig. 4. Generating a monochromatic diffuse source.



## A300 GLOSSARY, DEFINITIONS, ETC.

INCLUDING DEFINITIONS, NOTATION, VARIABLES, ABBREVIATIONS, AND ACRONYMS  
Numbers in brackets refer to section numbers in this document.

**a** – Aspect ratio of a screen, the width-to-height ratio. See 501-2 Aspect Ratio for more details.

**A** – Area of a surface.

**accuracy** – The accuracy is a qualitative term often used for the closeness of agreement between the measured value and the “true value” or value of the measurand. Inaccuracy is also a qualitative term often used for the same thing. These are not considered quantitative evaluations of measurement uncertainty (their use has fallen out of favor because they are used in so many different ways). See the section Statements of Uncertainty (A221) in the appendix for a full discussion of the matter.

**addressability** – The number of pixels in the horizontal and the vertical directions that can have their luminance changed; usually expressed in number of horizontal pixels by the number of vertical pixels,  $N_H \times N_V$ . This term should not be used synonymously with resolution—see “resolution,” also 303, especially 303-7.

**AFOV** – Angular field of view of an LMD, the angle from the LMD that subtends the measured region (often circular)—see 301-2h and A103-2.

**AMLCD, AM-LCD** – Active matrix LCD where each pixel (or subpixel) is powered by its own circuit or transistor affixed to the pixel.

**An.** – Abbreviation for “anomalous.” [306-6].

**anit-glare** – The control of glare reflections from a display is accomplished in several individual ways and in combination: (1) by distributing the specular energy in angles away from the specular direction, (2) by coating the front surface of the display with a multilayer coating to substantially reduce the specular reflections. (3) by controlling the reflection using polarizing materials.

**array detector** – Any of a variety of one and two-dimensional light detectors: Linear diode array, linear CCD array, CCD detector or CCD camera (two-dimensional array), and others. Often such devices have a substantial sensitivity to infrared light so that a photopic filter is needed to make accurate measurements of luminance. See A103 Light Measurement Devices and A111 Array Detector Measurements for more details.

**aspect ratio** – The ratio of screen width to screen height. See 501-2 Aspect Ratio for more details.

**background subtraction** – The process by which a background signal is subtracted from a measured signal. If a stimulus is zero and a signal in the detector is produced (from thermal noise, for example) then this is the background signal. If that signal is added to the measured signal when a measurement is made as a stimulus is applied, better accuracy of the measured signal is obtained by subtracting off the background. (A111)

**bits per color** – The number of bits available for each color, e.g., in an RGB system there may be 5 bits available for red and blue but 6 bits available for green which can be written as “5,6,5/RGB,” or “5R,6G,5B”; if 8 bits are available for each color then we could write “8ea RGB,” or simply “8 each.” [301-2a]

**bkg, Bkgnd., bkgnd** – Abbreviation for “background.”

**black** – The minimum luminance  $L_b$  attainable for the set conditions of the display. For example, with an RGB display, black is obtained when all three subpixels are at minimum luminance (smallest signal).

**black gloss light trap** – A gloss black surface used to provide a reference black in an area being measured. See “light trap” for more details.

**black screen** – A screen for which all pixels on the display surface are driven with the same stimulus in attempts to continuously display the same black level over the entire surface of the screen, where black means the minimum luminance, the lowest level that can be displayed.

**blanking** – The time interval used to identify and separate frames of video image information. During this time video image information is not being sent for display on the screen. It is a type of processing overhead.

**Blk, blk** – Abbreviation for “black.”

**blur** – The spatial spread of an intended point of light on a display screen. The term “blur” is used in optics to denote the degradation of images that are not in perfect focus; the image of a point is called a “blur circle” [See C. H. Graham, ed., Vision and Visual Perception (Wiley, 1966), pp. 518-520]. The term also applies to a display system. If the system is linear and shift-invariant, the blur of a point is mathematically described by what is known as the “point-spread function.”

- BRDF** – Bidirectional reflectance distribution function discussed in A217 in the Technical Discussions.
- brightness** – The visual and subjective quality of how bright an object appears, how much visible light is coming off the object being perceived by the eye. Luminance is not a quantitative replacement for brightness. One should avoid confusing luminance and brightness: brightness is subjective, luminance is objective. For a fuller explanation of the difference between brightness and luminance see A201 Photometry and Colorimetry Summary.
- C<sub>A</sub>** – Ambient contrast ratio: the white-black full-screen center luminance ratio under diffuse ambient illumination.
- C<sub>G</sub>** – Grille contrast ratio: the white-black luminance ratio of a series of equally spaced white and black lines.
- C<sub>L</sub>** – Line contrast ratio: the white-black luminance ratio of a white line to a black line, a white line to a black screen, or a black line to a white screen.
- C<sub>R</sub>** – Contrast ratio: the ratio of a white luminance to a black luminance  $L_w/L_b$ .
- C<sub>m</sub>** – Michelson contrast, contrast modulation: the ratio  $(L_w-L_b)/(L_w+L_b)$  where  $L_w$  is the white luminance, and  $L_b$  is the black luminance. It is not a sensitive metric for comparing large contrasts.
- C<sub>T</sub>** – Threshold contrast ratio: usually a minimum acceptable contrast for some condition, see 307-2 for example.
- Calc.** – Calculate.
- candela, cd** – Unit of luminous intensity in lumens per steradian ( $cd = lm/sr$ )
- CCD** – Charge coupled device. A type of one-dimensional or two-dimensional array light detectors (See array detector).
- CCT** – Correlated color temperature: The temperature (in Kelvin) of the black-body radiator whose chromaticity (a point on the Planckian locus) is closest to the chromaticity of a particular light (e.g., from a display screen) as measured in the 1960 CIE ( $u, v$ ) uniform chromaticity space. An algorithm for computing CCT, either from 1931 CIE ( $x, y$ ) coordinates or from 1960 ( $u, v$ ) coordinates, appears in G. Wyszecki and W. S. Stiles, *Color Science*, Second Edition, Wiley, 1982, pp. 224-228, where a graphical nomogram also appears. Alternatively, a successful numerical approximation has been derived by C. S. McCamy, *Color Res. Appl.* **17** (1992), pp. 142-144 (with erratum in *Color Res. Appl.* **18** [1993], p. 150). Given CIE 1931 coordinates ( $x, y$ ), McCamy's approximation is  $CCT = 437 n^3 + 3601 n^2 + 6831 n + 5517$ , where  $n = (x - 0.3320)/(0.1858 - y)$ . This approximation (the second of three he proposes) is close enough for any practical use between 2000 and 10,000 degrees Kelvin. See A201 for more information.
- cd, candela** – Unit of luminous intensity in lumens per steradian ( $cd = lm/sr$ )
- center of screen** – The geometric center of the image-producing portion of the display surface. [301-2i]
- CIE** – Commission Internationale de l'Eclairage (International Commission on Illumination). In this document we use the 1931 CIE ( $x, y, z$ ) chromaticity coordinates since they seem to be the lowest common denominator. The users of this document may prefer some other chromaticity coordinate system. Feel free to use whatever system you want as long as all involved parties agree. We especially recommend the ( $u', v'$ ) 1976 CIE chromaticity coordinates since the color space is more uniform relative to the eye's sensitivity to color. In this document we use photometric symbols:  $F, I, L, E, M$  for luminous flux, luminous intensity, luminance, illuminance, and luminous exitance, respectively. Please don't confuse our symbol for luminance  $L$  with any CIE measures of brightness.
- color** – This really doesn't need a definition. We simply want to note that white, grays, and black are considered colors in this context. Strictly speaking white and gray are colors, black is the absence of light, but in most cases "black" is, in reality, dark gray.
- color sequential** – A method of achieving a full-color displays by sequencing frames of the different primary colors rather than having each pixel be composed of subpixels of each primary color.
- collimation** – A process whereby a beam of light is provided where all the rays generated or employed are traveling in approximately the same direction across the cross-section of the beam.
- color depth** – The number of digital bits allocated for each primary color.
- cross talk** – Primarily an electronic term designating an unwanted coupling between adjacent or nearby circuits whereby the signal properties of one element is injected into the other element of the circuit. Cross talk has also been applied to the manifestation of cross talk in displays which manifests itself in three principal ways: shadowing, ghosting, and streaking. (Synonym: cross coupling, shadowing. See "shadowing," "ghosting," and "streaking")



$\Delta u'v'$  – Color difference metric in the 1976 CIE color space. See A201 for details.

$$\Delta u'v' = \sqrt{(u'_1 - u'_2)^2 + (v'_1 - v'_2)^2}$$

**D** – Screen diagonal

**dark field correction** – The subtraction of a background signal from the measured signal. Some detectors like CCDs have a background signal even when no light is present. To obtain accurate readings this background must be subtracted (pixel by pixel in the case of array detectors) from the measured signal. It is often measured by keeping the shutter closed or putting a black opaque (even to IR) cover on the imaging lens or aperture. (Synonym: background subtraction.) [A111]

**Daylight Eigenvectors** – Spectra based on observations of daylight that permit the resolution of any color of white into tristimulus values based on these spectra. See A222 Procedure for Verifying Digitally Driven Color Monitors and Table A222 in the table section A500.

**DHR** – Directed hemispherical reflectance—see 308-1 for its measurement.

**diffuse, diffusion** – A diffuse surface is characterized by a wide distribution of the incident light into all directions in the hemisphere before the surface. Examples are paper, matte paints, etc. A Lambertian surface is a perfect diffuser (it has the same luminance independent of the viewing direction—see “Lambertian”). Diffusion is the process of scattering light in directions away from directed ray or from the specular direction. See ASTM E284.

**design viewing direction, distance, point** – This document specifies that the normal direction (perpendicular to the screen surface) always be used for measurements. We do this for simplicity. However, we also recognize that some displays are designed to be viewed from a direction other than normal. Further, there may be a point in space from which the display has been designed to be viewed. An example of such a display is a privacy display that might be found on a bank-teller machine. If this document is used for measuring such a display, any non-normal design viewing direction or point must be clearly stated and agreed upon by all interested parties. It is left to the reader to make appropriate modifications in procedure to accomplish this. For example, in making uniformity measurements when a design viewing point exists, the luminance meter will be positioned so that its optical measurement axis is always looking at the positions on the display surface with the optical axis going through the design viewing point in space. [301-2g, 306]

**direct-view display** – A display for which the image or information generated by the pixel or image-producing surface is viewed without intervening instrumentation or apparatus, e.g., TV sets, computer CRT monitors, FPD desktop monitors, laptop computer displays. You are looking directly at the pixel surface and whatever covering material is employed to protect the pixel surface. There are no lenses involved such as with head-mounted, head-up, or projection displays. Lenticular microlenses in near proximity to the pixel surfaces are in the direct unassisted view and do not exclude the displays from being considered as direct view displays.

**Direct'n** – Abbreviation for “direction.”

**display** – An electronic device that presents information in visual form, that is, produces an electronic image—such as CRTs, LCDs, plasma displays, electroluminescent displays, field emission displays, etc. (Synonym: electronic display, DUT)

**display surface** – The physical surface of the display which exhibits information. (Synonym: screen)

**dithering** – A method of mixing pixels over an area of the screen where the pixels have different luminances or colors within the area in order to create a luminance or color which cannot be obtained by an individual pixel.

**dot** – This term can be ill-defined since there is confusion as to whether it refers to the full-color pixel or the subpixel. As best we can determine it is often used to mean each discrete primary colored element composing a full-color pixel or the subpixel. We strongly suggest the use of the term “subpixel” instead. (Synonym: subpixel)

**DPI** – This term can be ill-defined since there is confusion in its usage. Strictly speaking it means “Dots per inch,” but it has also been known as “lines per inch” or “pixels per inch.” For square pixels it is assumed to be symmetrical horizontally or vertically. Although dots may sometimes be considered to be subpixels, DPI usually refers to full pixels capable of the full color reproduction of the display, i.e., pixels per inch. We strongly suggest the use of the term “pixels per inch” instead of DPI to eliminate any possible ambiguity.

**driving stimulus** – The signal or voltage or bit count – whatever – which enables the display to change the luminance or color of the pixels. For example, in the case of an analog signal the luminance at a pixel might be a function of the applied voltage. In the case of a digital system, a bit-level will specify the luminance of the pixel. This vague term is used because we didn't want this document to be limited by a particular driving technology.

**DSO** – Digital storage oscilloscope.

**DUT** – Display under test.

**DVM** – Digital voltmeter.

**Dwn.** – Abbreviation for “down.”

**Eff.** – Abbreviation for “efficiency.”

**E** – Illuminance in lux,  $lx \equiv lm/m^2$ .

**EIAJ** – Electronics Industries Association of Japan (see Ref. [1]).

**EL** – Electroluminescent display technology for which film phosphors fluoresce from ac or dc currents.

**entrance pupil** – The full diameter of the light gathering aperture of an instrument, e.g., the diameter of a lens.

**F** – Luminous flux in lumens, lm.

**FED** – Field emission display technology for which each subpixel has an individual field-emitting protrusion electrode that activates a phosphor from electron bombardment.

**field** – See “frame rate.”

**fill factor** – Various definitions have been attached to this term. In general, the fill factor—often expressed in percent—is the fraction of the area allocated to a pixel which actually produces luminance. Given a display which has  $N$  horizontal pixels and  $M$  vertical pixels spread over an area  $A$  of the display, then the area allocated for each pixel is  $a_p = A / (NM)$ . Because of support structures, masks, etc. only a fraction of this area may serve to produce luminance, and that fraction  $f$  is the fill factor:  $a_1 = f a_p$ . This is all very simple when the luminance-producing area is relatively uniform and geometrically well-defined. But when it is not so well-defined the definition of the fill factor is not generally agreed upon. The luminance from such a pixel is an average:  $L_a = (1/a_p) \iint L(x, y) dx dy$ , where the integration is carried out over the allocated pixel area  $a_p$ . There is an associated maximum luminance of the pixel at some position  $(x_0, y_0)$ , call it  $L_p = L(x_0, y_0)$ . The fill factor is the ratio of the area of the region for which the luminance is above some chosen threshold luminance level  $L_t$  to the area allocated to the pixel  $a_p$ :  $f = (1/a_p) \iint U(x, y) dx dy$ , where  $U(x, y)$  is a criterion function which is nonzero and unity only where the luminance is at or above the threshold, i.e.,  $U(x, y) = 1$  whenever  $L(x, y) \geq L_t$  and  $U(x, y) = 0$  for  $L(x, y) < L_t$ . Often the threshold is taken as some fraction of the peak luminance:  $L_t = \xi L_p$ . Some choose the 50 % luminance threshold which is easy to measure using a spatially resolved luminance measurement system. We would argue that since the eye is a nonlinear detector, it makes much more sense to use 20 % or lower level for the threshold (some like 10 % or even 5 % to indicate a width) since the eye would perceive about a 50 % brightness falloff at 20 % of the luminance (see A201 and A209). When color subpixels combine to make a single pixel, use the luminance relative to the peak luminance for each subpixel and then sum the results for each subpixel to produce the fill-factor for the entire pixel which yields a higher fill factor than if the same luminance criterion is used for all subpixels. The higher result is believed to be a better representation of how the eye would evaluate the fill factor; for example, although a blue subpixel may be very dim compared to a green subpixel, the 10 % level of the blue “combines” with the 10 % level of the green and the 10 % level of the red to produce 10 % of white. It is in this sense that the 10 % blue level is, therefore, just as important as the 10 % green level. [303-3]

**flare** – see “veiling glare.”

**flat field correction, FFC** – An array detector may have a slightly different sensitivity for each pixel in the array.

A flat field correction is an array of numbers—each number multiplies a signal from each pixel—to correct for the changes in sensitivity.

**flicker** – Perceptible rapid temporal luminance variation of a nominally constant-luminance test pattern.

**FOV** – Field of view of an LMD, the region on the display that is being measured by the LMD.

**foveal vision** – vision near the eye's fixation point, i.e., with the part of the visual field that is within 2.6 degrees of visual angle of the optical axis of the eye (see Wyszecki and Stiles, 1982, p. 89). This part of the visual field corresponds to a part of the retina (light-sensitive area of the eye) that is characterized by a pit (hence the Latin term fovea meaning pit). There is a pit because the neural material is pushed aside and the cones (bright-



light-sensitive cells) in the eye are abutted in maximum density, evidently for maximum resolution of spatial detail in bright light. However, when there is not enough light (e.g., when looking at dim stars at night), fixating on a star may make it disappear because only rods (dim-light-sensitive cells) operate in such dim light, and rods are absent from the fovea.

**FPD** – Flat panel display.

**fps** – frames per second (not to be confused with fields per second).

**frame** – The image displayed (or the signal for the image) during the frame rate.

**frame rate** – The shortest period of time in which all pixel information and blanking is delivered to the display.

Examples of frame rates are 24 fps for movies, 30 fps for NTSC video, 60-85 Hz for CRT computer monitor displays, etc. For interlaced (non-progressive) displays, the frame may consist of two sequential fields of video information where alternative horizontal pixel lines are used for each field. The field rate would be twice the frame rate, e.g., 60 field per second for NTSC video.

**full screen** – Refers to a display surface condition whereby any single color (white, black, blue, etc.) exhibited over the entire surface.

**gamma** – Refers to the exponent of the stimulus in a luminance versus stimulus mathematical model—see “gray-scale model” below or 302-5 Gray Scale of Full Screen.

**ghosting** – A form of crosstalk with a shorter spatial/temporal duration that manifests itself as a faint offset image from the main intended image (see “crosstalk”).

**glare** – General term referring to undesirable light introduced into the measurement because of imperfections in the optical system. See more specific terms “lens flare” and “veiling glare.” For the most part, we don’t employ this word in the sense used in ergonomics, where the effects of reflections are considered in the readability of a screen.

**gloss** – A property of reflection whereby either distinct images (specular reflection) or quasi-distinct images (highlights) can be seen of the objects in the specular direction. See ASTM E284.

**gloss black** – Gloss-black plastic material made of vinyl plastic approximately 0.25 mm (0.010 in) thick is most often referred to in this document. Gloss refers to the ability of a material to produce a distinct image of the light source in the reflection of that light source. Gloss black paints, available at any hardware store, may also be used. The specular reflectance is often about 5 % whereas the luminance factor is often from 1 % to 2 % depending upon the quality of the plastic or paint.

**graphics** – Display of information in the form of lines and geometric shapes to which colors, fills, patterns, or textures are assigned.

**gray level** – One particular gray luminance of the black-to-white available luminances of a display. The number of distinct levels of gray that the display is capable of producing includes white and black, e.g., 8-bit or 256.

**gray scale** – The range of luminances obtainable from a display from black to white.

**gray-scale model** – *Digital Signal Bit Levels:* Given  $n$  levels of gray that can be displayed on a screen, with 0 for black and  $w = n - 1$  for white. We want to select a subset of  $m$  levels that are as evenly spaced as possible. The interval between the  $n$  levels to create  $m$  levels is  $\Delta V = w/(m-1)$ , which may not be an integer. So, the levels to select are the (integer) values of  $V_i = \text{int}[(i-1)\Delta V]$  for  $i = 1, 2, \dots, m$ , or  $V_i = 0, \text{int}(\Delta V), \text{int}(2\Delta V), \text{int}(3\Delta V), \dots, \text{int}[(m-1)\Delta V]$ , with  $\text{int}[(m-1)\Delta V] = w$  for white. For example, if there are  $n = 256 = 2^8$  levels from which we select  $m = 8$  levels, white is  $w = 255$ ; the interval is  $\Delta V = 36.4286$ , and the chosen levels are: 0, 36, 73, 109, 146, 182, 219, 255. *Analog Signal Levels:* For analog signals, if  $V_w$  is the white level and  $V_b$  is the black level, then for  $m$  levels the signal step size is  $\Delta V = (V_w - V_b)/m$ . If we chose black as 0 and white as 1 then the  $m = 8$  gray-levels would be: 0, 0.1429, 0.2857, 0.4286, 0.7143, 0.8571, 1 with  $\Delta V = 0.1429$ . Similarly, if black is 0 and white is 100, then the eight gray levels would be 0, 14.286, 28.571, 42.857, 57.143, 71.429, 85.714, 100.

**H** – Horizontal size (width) of the viewable screen actively producing an image (this assumes a rectangular screen). See  $V$  for vertical size.

**halation** – The leakage of light from bright areas of the image into the dark areas because of reflection or diffusion arising from the materials used in the construction of the display, their configuration, or cross-coupling in the circuitry that produces a corruption of black from surrounding white areas. Reflections off the covering material (e.g. front glass of CRT) and within or along the display surface (e.g., phosphor surface of CRT) are examples.

- halo** – The light that is scattered from bright areas of a display into dark areas usually appearing as a ring or outline surrounding the bright area. See Halation.
- haze** – The property of reflection that is like specular in that it is directed in the specular direction, but does not create a distinct virtual image of the source, and it is proportional to the incident illuminance (see A217). See also ASTM E284 where haze is connected with specular reflection manifesting itself as a reduction of contrast of the distinct image because of diffusion of the light from the strict specular direction.
- HDTV** – High definition television.
- height** – The vertical height  $V$  of the viewable screen actively producing an image.
- $I$**  – Luminous intensity in candela,  $\text{lm/sr} \equiv \text{cd}$
- illuminance** – The amount of light  $E$  falling upon a surface (or passing through a surface) expressed in  $\text{lm/m}^2$ . See A201 and A202 for more details.
- image** – A display of information in the form of pictures of real-world objects or similar renderings usually having a continuous range of gray scales and colors. This is in distinction to graphics, see “graphics.”
- imprecision** – See “precision”—This is an imprecise term to use to describe uncertainty.
- inaccuracy** – See “accuracy” —This is an imprecise term to use to describe uncertainty.
- integrating sphere** – A hollow sphere with the interior surface coated with a white material usually of very high reflectance (but not always). It has an entrance port for an input light source and an exit port to provide a source of luminance. If the exit port is 1/3 the diameter of the sphere or less and the interior white surface has a luminance factor of 98 % or more, then the nonuniformity of the luminance across the exit port can be nearly 1 %. (See A113 Auxiliary Laboratory Equipment and A210, A211, A212 in the Technical Discussion Section for more details.)
- interested parties** – All the companies and individuals who have negotiating authority in the commerce of an electronic display.
- IR** – Abbreviation for infrared light.
- isotropic** – Used to describe the nature of anything that has the same property in all directions.
- JND** – Abbreviation for Just-Noticeable Difference, a perceptually based unit of measure for the magnitude of difference between two stimuli. In JND units, two stimuli (e.g. an image sequence and a degraded counterpart) differ by 1 JND if an observer can discriminate between the stimuli with 75 % accuracy. There is a model based on human vision (called the Sarnoff Vision Model—see Lubin, et al., 1995, 1997) that predicts the discriminability (and perceptual difference) between two image sequences in JND units. Multiple JNDs can be interpreted as follows: a 1-JND difference has small perceptual impact; a 3-JND difference is almost always observable but not strong; a 10-JND difference is clearly observable. References: 1. J. Lubin, A visual system discrimination model for imaging system design and evaluation, in E. Peli (ed.), *Visual Models for Target Detection and Recognition*, World Scientific Publishers, 1995. 2. J. Lubin, M. Brill, and R. Crane, Vision model-based assessment of distortion magnitudes in digital video, presented at the November, 1996 meeting of the International Association of Broadcasters (IAB).
- K** – Kelvin, the unit of absolute temperature (say “kelvin” NOT “degrees kelvin”).
- $L$**  – Luminance in  $\text{cd/m}^2$ . At one time this unit,  $\text{cd/m}^2$ , was called “nit,” but that is no longer considered to be proper terminology. Please don’t confuse this with any of the CIE measures of brightness.
- Lambertian** – A property of a surface where the luminance is independent of the angle from which the surface is viewed—see A203 for details.
- $L_b$**  – Luminance of black.
- $L_w$**  – Luminance of white.
- LCD** – Liquid crystal display, a display technology for which there are a number of varieties: active-matrix (AMLCD), thin-film-transistor (TFT), super-twisted-nematic (STN), etc. A liquid-crystal material sandwiched between electrodes (one of which is often transparent) that changes its reflectivity or transmissivity as a function of voltage.
- lens flare** – Please see “veiling glare.”
- LMD, light measurement device, light measuring device** – Any one of a variety of devices used to measure light, luminance, color, or color temperature. It can include a luminance meter, colorimeter, spectroradiometer, photodiode, photomultiplier tube, etc. depending upon the requirements for the measurement.
- light measurement device, light measuring device** – See “LMD” above.



**light trap** – Any of a variety of objects which are used to provide a reference black in a region in which luminance (or color) is being measured. To obtain the blackest reference use a gloss-black circular cone with a narrow apex angle where the apex of the cone is squeezed together or bent around so that there is no surface of the gloss-black material which faces the opening. When the requirement for a black reference is not so stringent, a gloss-black surface is employed. The reason for the glossy (specular) surface is that less light is likely to reflect from the environment into the LMD than would be encountered using a matte black surface. (Synonyms: black gloss light trap, black trap, black light trap, light trap) [A113]

**linear regression** – Given a linear functional form  $y = mx + b$  suppose we have a number  $N$  of measurement pairs  $(x_i, y_i)$  and we want to extract the best coefficients  $m$  and  $b$  to fit these data. (For example,  $y$  might be the temperature of a furnace and  $x$  might be the time from turning on the furnace; we could measure the temperature as a function of time and desire to fit the data to a straight line so we can get an estimate of the rate of increase of temperature of the furnace  $m$  starting at the ambient temperature  $b$ .) The linear regression or fit of these data provide the following values for  $m$  and  $b$ :

$$b = \frac{1}{\Delta} \left( \sum_{i=1}^N x_i^2 \sum_{i=1}^N y_i - \sum_{i=1}^N x_i \sum_{i=1}^N x_i y_i \right), \text{ and } m = \frac{1}{\Delta} \left( N \sum_{i=1}^N x_i y_i - \sum_{i=1}^N x_i \sum_{i=1}^N y_i \right), \text{ where } \Delta = N \sum_{i=1}^N x_i^2 - \left( \sum_{i=1}^N x_i \right)^2.$$

The goodness of the linear fit is measured by the correlation coefficient  $r$  given by

$$r = \frac{N \sum_{i=1}^N x_i y_i - \sum_{i=1}^N x_i \sum_{i=1}^N y_i}{\left[ N \sum_{i=1}^N x_i^2 - \left( \sum_{i=1}^N x_i \right)^2 \right]^{1/2} \left[ N \sum_{i=1}^N y_i^2 - \left( \sum_{i=1}^N y_i \right)^2 \right]^{1/2}},$$

which can be positive or negative but its absolute value is a maximum of one for a perfect fit and zero for no correlation (indicating that the data are random, not linear). These kinds of calculations are found in scientific calculators and spreadsheets. [302-5, etc.]

**loading** – A change in the display performance that accompanies the change in power consumed by the electronics used in creating the image. For example, the white luminance displayed on a CRT can be dependent upon the area of the white region being displayed, the larger the white area, the dimmer the white luminance. There can also be spatial distortions of the image because of loading effects.

**Lum.** – Abbreviation for “luminance.”

**lumen** – A quantification of visible light power, abbreviated lm. See A201 and A202.

**luminance** – Relates to the quantification of the colloquial technical term for the brightness of a surface.

Luminance is expressed in  $\text{cd}/\text{m}^2$ . See A201 and A203.

**luminance adjustment range** – The range of adjustment in the luminance of a full-white screen provided as a control (software or hardware) with the display. (Synonyms: dimming range, percent of luminance variation, dimming ratio, brightness range, range of brightness)

**luminance coefficient** – The ratio of the luminance to the illuminance for a Lambertian reflector:  $q = L/E$ , where  $q = r_d/\pi$ , and  $r_d$  is the luminance factor.

**luminance factor** – The fraction of incident luminous flux reflected from a surface, often in reference to

Lambertian reflectance where the luminance is related to the illuminance by  $L = r_d E/\pi$ .

**luminous exitance** – The amount of light  $M$  exiting a surface expressed in  $\text{lm}/\text{m}^2$ .

**lux, lx** – unit of illuminance and luminous exitance in lumens per square meter ( $\text{lx} = \text{lm}/\text{m}^2$ ).

$u_{\text{LMD}}, U_{\text{LMD}}$  – The combined standard uncertainty of the LMD and the expanded uncertainty of the LMD (usually with a coverage factor of two), respectively.

**$M$**  – Luminous exitance in  $\text{lm}/\text{m}^2$ .

**matte** – A reflection property of a surface that diffuses the incident light in quasi-Lambertian manner, i.e., the surface appears approximately the same brightness from all directions and there are not highlights or distinct reflections of sources. Often the term “diffuse” is also used in this manner. We speak of diffuse white standards and matte white paint, both refer to the same kind of reflection, although when we speak of a diffuse white standard we generally mean a material that is as close to a Lambertian reflector as possible.

**mean** – The mean ( $m$ ) of  $n$  measurements of quantities  $x_i$  is  $m = \frac{1}{n} \sum_{i=1}^n x_i$

**Meas.** – Measure.

**Michelson contrast** – An expression for the contrast given by  $C_m = (L_{\max} - L_{\min}) / (L_{\max} + L_{\min})$ , where  $L_{\min}$  is the minimum luminance and  $L_{\max}$  is the maximum luminance under consideration.

**Moiré pattern** – An undesirable visible luminance modulation which has a spatial variation usually substantially larger than the pixel-to-pixel separation. It usually appears as a small quasi-linear two-dimensional luminance wave across a large portion of the screen.

**moving-window-average filter** – Let the LMD sample rate be  $s$ , the raw time-dependent light measurements taken at intervals of  $1/s$  be  $L_i$ , and define the window  $\Delta N$  as the number of light data points over which an average is to be performed, then the resultant window-average-filtered signal for any data point  $i$  is  $S_i$  given by

$$S_i = \frac{1}{\Delta N} \sum_{n=i}^{n=i+\Delta N-1} L_n.$$

As this window-average filter moves along the data 0, 1, ...,  $i$ ,  $i+1$ ,  $i+2$ , ..., it creates a new set of data  $S_i$  from the original data. This process is referred to as subjecting the raw data to a moving-window-average filter, and the process manages to average out high frequency irregularities which are narrower than the window width. (Also loosely termed a running average.)

**monochrome** – In this document a monochrome display means that the display uses only one color to display its information (with or without multiple luminance levels). The display might show two colors, but the contrast used to display information is only derived from one color other than a background color. Some examples are black-and-white displays or blue-and-yellow displays, etc.

**MPCD** – Mean perceptible color difference.

**Muncel Colors** – In this document eight reflectances are specified for unsaturated colors possibly useful in digital calibration of displays. See A222 Procedure for Verifying Digitally Driven Color Monitors and Table A222 in the table section A500.

$N_H, N_V$  – Number of pixels horizontally, vertically.

**NDF** – Neutral density filter. See A113 Auxiliary Laboratory Equipment.

**negative, negative screen, negative configuration** – white (or light) letters on a black (or dark) screen.

**normal** – The normal or perpendicular to the surface of the screen. We specify that measurements should be made from the screen normal. Any other arrangement for a non-normal design viewing direction must be explicitly stated and agreed upon by all parties involved. See “design viewing” for a discussion of non-normal viewing of a display. (Synonym: screen normal, perpendicular to screen)

**NTSC** – National Television System Committee

**OEM** – Original equipment manufacturer. It usually refers to those manufacturers who integrate manufactured components together into a finished commercial product.

**Opt.** – Abbreviation for “optional.”

**palette** – The number of different colors that can be generated under all circumstances of use. Note that this can be a much larger number than the total number of colors that can be displayed at any given time. See “total number of colors.”

**PC** – Personal computer

**PD, PDP** – Plasma display, plasma display panel. A flat panel technology for which inert gas is ionized thereby producing ultraviolet light which, in turn, causes phosphors to fluoresce.

**PDF** – Adobe’s Portable Document Format® for electronic file reading of printed documents. Adobe’s reader is available from their web site for any major computer platform ([www.adobe.com](http://www.adobe.com)).

**PE** – Polyethylene

$P_H, P_V$  – Number of pixels in the horizontal direction, in the vertical direction, which defines the active area of the screen.

**photometry** – Measurement of any quantity connected with the wavelength integral of an electromagnetic spectral power distribution, weighted by the CIE 1931  $V(\lambda)$  function.

**photopic, photopic response, photopic correction** – Apparatus that exhibits a spectral response according to the the CIE 1931  $V(\lambda)$  function (or nearly so). This is the transformation of spectral power measurements to luminous equivalents, through multiplication by the CIE 1931  $V(\lambda)$  weighting function, integration in



wavelength  $\lambda$ , and multiplication by the appropriate conversion factor (e.g., 683 lumens/watt). If the light emitter is one square meter of Lambertian surface viewed from the normal direction, the luminous flux (in lumens) is numerically the same as the luminance in  $\text{cd/m}^2$ . [A201]

**PMT** – Photomultiplier tube.

**PSF** – Point spread function—refers to the flux density in the image plane associated with a point source in the object plane of an optical system.

**PTFE** – Polytetrafluoroethylene (common trade name of Teflon®, a registered trade name of Dupont)

**percent change** – Given an initial value of a quantity  $Q_i$  and a final value of the same quantity  $Q_f$ , the percent change relative to the initial value is given by  $100\%(Q_f - Q_i)/Q_i$ ; relative to the final value it's  $100\%(Q_f - Q_i)/Q_f$ .

**peripheral vision** – vision with the part of the retina at least 14.5 degrees away from the eye's optical axis (see Wyszecki and Stiles, 1982, p. 89). In the peripheral retina, there are far more rods (dim-light-sensitive cells) than cones (bright-light-sensitive cells). Therefore, the perception of color and spatial detail is much less in the periphery than in the fovea. However, dim stars that are invisible in the fovea are visible using peripheral vision (especially near the inner margin of the periphery, about 20 degrees away from the optical axis--See T. Cornsweet, *Visual Perception*, Academic, 1970, p. 137).

**pitch** – The separation between the center of two adjacent pixels which is the same as the distance between identical points on two adjacent pixels. It is expressed in a distance/pixel such as 0.2 mm/px or just distance as 0.2 mm. This is the same as the reciprocal of the number of pixels per unit distance. [501]

**pixel** – Picture element: A pixel is the smallest element of the display surface which can reproduce the full range of luminances and colors of the FPD. Often the pixel is composed of subpixels (or dots). (Symbol: px)

**positive, positive screen, positive configuration** – black (or dark) letters on a white (or bright) screen (like white paper with black letters on it).

**power** – Rate of energy transfer in units of watts (joules per second), in electrical terms: power = voltage  $\times$  current or  $P = VI$ .

**precision** – The precision a qualitative term often used for the closeness of agreement between consecutive measurements. Imprecision is also a qualitative term often used for the same thing. These are not considered quantitative evaluations of measurement uncertainty (their use has fallen out of favor because they are used in so many different ways). See the section Statements of Uncertainty (A221) in the appendix for a full discussion of the matter.

**primary colors** – The color of the each separate subpixel. In RGB displays the primary colors are red, green, and blue. These are the colors that are most saturated and furthest from the white point. In a linear color space these primary colors will lie at the corner points of the polygon representing the color gamut. Our notation for the primary and secondary colors based on RGB is a three letter subscript: “red” for red, “grn” for green, “blu” for blue, “cyn” for cyan, “mag” for magenta, “yel” for yellow, e.g.,  $L_{yel}$ ,  $L_{red}$ ,  $L_{gm}$ , etc.

**px** – Symbol for pixel.

**pt** – Abbreviation for a point.

**$q$**  – Luminance coefficient of a surface whereby the luminance is related to the illuminance by  $L = qE$ . Usually it is implicitly assumed that the reflection is Lambertian so that the luminance doesn't change with viewing direction of the surface.

**$Q$**  – Defective pixels clustering quality.

**$r$**  – Reflectance either expressed as a number or percentage.

**$r_d$**  – Luminance factor: The luminance  $L$  of a Lambertian sample of reflectance  $r_d$  subjected to illuminance  $E$  is given by  $L = Er_d/\pi$ .

**$r_s$**  – Specular reflectance: The luminance  $L$  from a specular (mirror-like) surface arising from a source luminance  $L_s$  is given by  $L = r_s L_s$ . If the source luminance  $L_s$  is at an angle of  $q$ , the incident angle, from the perpendicular of the surface, then the direction of the reflected light, the specular direction, is the reflection angle  $-q$  from the perpendicular where the perpendicular, the incident ray, and the reflected ray all lie in the same plane.

**$R_I$**  – Symbol for residual image.

- radiometry** – The measurement of any quantity connected with electromagnetic radiation.
- ray** – The path of an infinitely narrow beam of light.
- reflection** – The process whereby luminous flux incident upon the surface of a display is redistributed with or without attenuation anywhere in the hemispherical area in front of the display. [308]
- replica mask** – A black mask that is of the same size shape as a black area on the screen in order to determine a suitable correction for glare and having a reference black. [A101]
- residual image** – Partial remains of an image after the content has changed, the remnant of a video image on the screen after the original image is removed electronically. It is generally most pronounced for cases where the image was unchanged for long periods of time, and/or had high contrast. The duration of the image to produce a residual image and amount and techniques for recovery are technology-dependent. (Section 305-2. Synonym: latent image, image retention) Note: Testing for residual image could result in permanent damage to the display.
- resolution** – Often this means addressability, that is, we say a  $1024 \times 768$  pixel display or  $P_H \times P_V$  display which is the addressable horizontal and vertical pixels. Resolution, defined strictly, refers to how well the eye can distinguish two objects that are close together. Unfortunately, resolution has come to be used synonymously with addressability, but not in this document. If a display is poorly designed, it may have a large addressability but not be able to be resolved at that same spatial frequency.
- repeatability** – The repeatability of an instrument may be characterized by the standard deviation associated with a series of measurement results made in an identical manner in a short period of time. See A221 Statements of Uncertainty for more details.
- reporting document, reporting documentation** – Any reporting mechanism used to technically describe the performance or features of a display. It would include advertisements used to distinguish one display from another based on any measurement results from the use of this document.
- reproducibility** – The reproducibility of an instrument may be characterized by the standard deviation associated with a series of measurement results made over a long period of time; using different operators; different temperatures, humidity, and pressures (within the operating specifications of the instrument); etc. [A221]
- RH** – Relative humidity.
- Ronchi ruling** – A series of black opaque lines on a clear substrate (like glass) where the clear line width is the same thickness as the opaque line width. The ruling should always be observed from the ruling side in order to obtain maximum contrast. If it is observed from the substrate side then reflections in the substrate will degrade the observed contrast. [A113]
- running average** – See moving-window-average filter. [A218]
- $s_{LMD}$**  – The repeatability requirement placed upon any LMD used for measurements based upon this document. [A101, 301-1]
- $s$**  – pixel spatial frequency, the inverse of the pitch,  $s = 1/P$ .
- SBM** – Suite of Basic Measurements: Selected measurements that are considered to be a small set of important measurements. See the Reporting Section (200) for a complete discussion.
- screen** – The physical surface of the display which exhibits information, the area of the display which has images electrically generated. In general it is the physical pixelated area, although in some cases, like projection display, it can be optically displaced from the actual pixel area. For direct view, fixed-format pixel displays, the image area will always be the pixel matrix. (Synonym: display surface, display face, viewing area, active area, active viewing area, viewable area)
- screen height** – The linear measure of the height of the displayable surface measured at center screen.
- screen normal** – See “screen perpendicular” below.
- screen perpendicular** – A line which is normal or perpendicular to the surface of the screen; often the center of the screen is the reference point on the surface from which the perpendicular is determined. (Synonym: perpendicular, normal, orthogonal, screen normal)
- screen width** – The linear measure of the width of the displayable surface measured at center screen.
- secondary colors** – Combinations of two of the primary colors at full intensity. For the RGB system they are cyan (B+G), magenta (B+R), and yellow (R+G) where we denote associated variables with three letter subscripts “cyn,” “mag,” and “yel,” respectively.
- shadowing** – Cross coupling, or crosstalk, between any part of the pixel addressing architecture might occur in certain circumstances when there are images of varying luminances or colors displayed. This could result in an



image of one luminance level or color producing a shadow of equal or unequal luminance or color across some area of the display that has a different luminance level or color. (Synonym: cross talk, trailing, cross-coupling, streaking, ghosting. See “crosstalk.”) [303-4]

**sheen** – The production of a distinct virtual image of reflected objects from a matte or diffusing surface when objects are viewed at grazing angles (angles far from the normal of the surface).

**Shad.** – Abbreviation for shadowing (see above).

**SI** – The International System of Units, universally abbreviated “SI” coming from the French *Le Système International d’Unités*.

**SMPTE** – Society of Motion Picture and Television Engineers

**solid angle** – The ratio of the area of a portion of a spherical surface to the radius of that spherical surface. See A202 for more details.

**spatial frequency** – The number of items per unit distance. For example, if the separation between the center of two adjacent pixels is 0.2 mm (the pitch), then the associated spatial frequency of the display is the inverse of this:  $5 \text{ (mm)}^{-1}$  or 5 pixels/mm.

**specular** – A type of reflection whereby the luminous flux incident upon a display surface from an angle  $q$  with respect to the normal is reflected in a direction  $q$  on the other side of the normal directly opposite the incident angle. In this document it will usually refer to that part of reflection that produces a distinct (mirror-like) virtual image of the source. See ASTM E284 where it is defined as “reflection without diffusion, . . . , as in a mirror.”

**specular reflectance** – The ratio of the luminance of the specular virtual image to the source luminance for the component of reflection that defines a mirror-like distinct virtual image of the source:  $r_s = L/L_s$ .

**standard deviation** – If there are  $n$  measurements of quantities  $x_i$ , the standard deviation  $\sigma$  is defined in terms of

the mean  $\mu$  as: 
$$s = \sqrt{\frac{1}{n-1} \sum_{i=1}^n (x_i - m)^2} .$$

**Std., std., std** – Abbreviation for “standard.” Usually associated with a white diffuse standard material having a known (calibrated) reflectance.

**StdDev.** – Abbreviation for “standard deviation.”

**STN** – Super-twisted-nematic type of LCD.

**streaking** – Short-term or short-distance shadowing, which is a form of cross-talk whose effect decays over a distance on the display (see “cross-talk”).

**subpixel** – The smaller elements which can compose a pixel. For example, an RGB display can have each pixel composed of three subpixels: a red, green, and a blue subpixel (sometimes there are two green subpixels for a total of four subpixels per pixel). Thus, a subpixel is each discrete primary colored element composing a full-color pixel. (Synonym: dot)

**sunlight readability** – Displays that are sufficiently bright or that minimize reflections (or both) to be readable in direct sunlight. It is important to realize that there can be a difference between specular sunlight readability (looking directly in the direction of the reflected image of light source) and sunlight readability referring to non-specular viewing (where the light source is positioned to not be in the specular direction).

**task** – The conditions under which a display is used to achieve a particular purpose or goal. It can include the type of information that is displayed as well as the surround or environment in which the display and operator is placed. [301-3]

**text** – display output in the form of printed text, usually it has high contrast or good color contrast to make it as readable as possible.

**total color bits** – The total number of bits available for color rendering (including grays). For a 5,6,5/RGB system we have 16 bits for the total color bits, the 8-bits each RGB system gives 24 bits for the total color bits. [301-2a]

**total number of colors** – The number of different colors that can be displayed at any one time. Thus, although a display may allocate 8 bits for each color RGB giving a palette of  $16.78 \times 10^6$  colors, if only 256 of those colors can be allowed on the screen at any time, then the total number of colors would be 256. If we wanted to specify the palette in addition, we would say that there could be a total number of 256 colors from a palette of  $16.78 \times 10^6$  colors. [301-2a]

**u, v** – Chromaticity coordinates for the 1960 CIE color space. See A201 for details.

$u'$ ,  $v'$  – Chromaticity coordinates for the 1976 CIE color space. See A201 for details.

**Unif.** – Abbreviation for “uniformity.”

$v$  – signal level, bit level, analog signal level

**V** – Vertical size (height) of the viewable screen actively producing an image (this assumes a rectangular screen).

See *H* for horizontal size. Also, signal level, bit level, and analog signal level.

**VDU** – video display unit

**veiling glare** – Precise definitions may not be attached to this term and “lens flare,” but, in general, lens flare refers to a strikingly non-uniform stray light that is introduced by reflections off the lens surfaces within a lens. Defined this way, lens flare is often very visible. (For example, when a camera is pointed in the general direction of the sun the bright illumination from the sun hits the lens and makes numerous rings, lines, and colored patches visible.) Veiling glare, on the other hand, is often used to refer to the less obvious and somewhat more uniform stray light that floods the entire region of the detector with light, corrupts dark areas with white (or color), or mixes colors. It can be introduced also by reflections within the lens system or scattering from dirt and other objects associated with the lens system. [A101]

**video** – In this document we often use “video” to refer to either a static or dynamic image produced on a screen. It can also be used to refer to the signal input to a display, or to represent electronic image producing technology, in general.

**vignette** – When using a lens to produce an image the image will be observed to get darker as you move further away from the center of the image on the axis of the lens. This type of darkening is called a vignette (French, pronounced: vin-yet´). The effect, either light or dark, is often used in portrait photography to soften the area around the face or bust and blend in the background. When imaging with a lens an aperture placed between the object and the lens can produce an out-of-focus image of the aperture with the image of the object within the out-of-focus or fuzzy image of the aperture. This fuzzy framing of the observed object is called a vignette.

**warm-up, warmed-up, warm-up time** – Refers to a minimum time required to elapse before any measurements can be made and recorded for the purposes of this standard. The warm-up time is the time required for a display to reach luminance stability after it has been off for a sufficiently long time so that it starts at the ambient temperature at the turn-on time. Note that we recommend a 20-min warm-up time as a standard setup conduction (301-2d). This test allows the user to either verify that the 20-min time is adequate or determine if a different amount of warm-up time is suitable or needed. [305-3]

**warm-up time measurement** – A measurement of the time required to reach a certain luminance stability criterion for a specified screen condition such as full-screen white (not used in the Basic Measurement Suite).

**width** – The horizontal size *H* of the viewable screen actively producing an image.

**window average** – See moving-window-average filter.

**white** – The maximum luminance  $L_w$  attainable for the set conditions of the display. For example, with an RGB display, white is obtained when all three subpixels are at maximum luminance (largest signal).

**white screen** – A screen for which all pixels on the display surface are driven with the same stimulus in attempts to continuously display the same white level over the entire surface of the screen, where white means the maximum luminance. [302-1]

**Wht, wht** – Abbreviation for “white.”

**x, y, z** – 1931 CIE chromaticity coordinates. [A201]

**x, y, z** – Right-handed Cartesian coordinate system with *z* as the axis normal to the display (assuming the surface is vertical), *y* is the vertical axis, and *x* is the horizontal axis. [300]



### Acronyms and Abbreviations that may be of interest:

ACATS	Advisory Committee on Advanced Television Service
AEA	American Electronics Association
ALARA	as low as reasonably achievable
AMLCD	active matrix liquid crystal display
ANSI	American National Standards Institute
ARPA	Advanced Research Projects Agency (formerly DARPA)
ASTM	American Society for Testing and Materials
ASS	Swedish Nation Board of Occupational Safety and health
ATSC	Advanced Television Systems Committee
ATTC	Advanced Television Test Center (created by broadcasting companies and industry organizations in 1988 to test proponent advanced television transmission systems. Alexandria, VA)
ATV	advanced television
B-ISDN	Broadband Integrated Services Digital Networks
BIPM	Bureau International des Poids et Mesures (International Bureau of Weights and Measures)
BRDF	bidirectional reflectance distribution function
BSDF	bidirectional scattering distribution function
BTDF	bidirectional transmittance distribution function
CATV	cable TV
CCIR	International Radio Consultative Committee
CCITT	International Telephone and Telegraph Consultative Committee
CCPR	Consultatif Comité de Photométrie et Radiométrie (Consultative Committee of Photometry and Radiometry)
CD	committee draft
CEN	Comité Européen de Normalisation (European Standards Committee)
CENELEC	European Committee for Electrotechnical Standardization
CGPM	Conférence Générale des Poids et Mesures (General Conference of Weights and Measures)
CIE	Commission Internationale de l'Eclairage (International Commission on Illumination)
CIPM	Comité International des Poids et Mesures (International Committee for Weights and Measures)
COHRS	Committee on High Resolution Systems
CORM	Council for Optical Radiation Measurements
CSF	contrast sensitivity function
CSL	Computer Standards Laboratory
DAB	digital audio broadcasting
DARPA	Defense Advanced Research Projects Agency
DIN	Deutsches Institut für Normung (German Institute for Standardization)
DIS	draft international standard
DSRC	David Sarnoff Research Center
DUT	display under test
EC	European Community
EEC	European Economic Community (often use EC above as substitute)
EFTA	European Free Trade Association
EIA	Electronic Industries Association
EIAJ	Electronic Industries Association of Japan
ESF	edge spread function
FED	field emission displays
FCC	Federal Communications Commission
FPDM	Flat Panel Display Measurements Standard (VESA)
HDTV	high definition television
HRI	high resolution imaging
HRIS	high resolution information systems
IEEE	Institute of Electronics and Electrical Engineers
IEC	International Electrotechnical Commission



ISO	International Organization for Standardization
IS&T	Society for Imaging Science and Technology
ITU	International Telecommunication Union
LMD	light measuring device (in VESA FPDM)
LSF	line spread function
MAC	Multiple Analog Component
MPR	Swedish National Board for Measurement and Testing
MTF	modulation transfer function
MUSE	Multiple Sub-Nyquist Sampling Encoding System (Japanese HDTV system)
NAB	National Association of Broadcasters
NIDL	National Information Display Laboratory (at DSRC)
NIST	National Institute of Standards and Technology (USA)
NPL	National Physical Laboratory (UK)
NRC	National Research Council (Canada)
NRLM	National Research Laboratory of Metrology (Japan)
NTIA	National Telecommunications and Information Administration
NTSC	National Television System Committee
OSTP	Office of Science and Technology Policy (part of the Executive Office of the President)
OTF	optical transfer function
PIMA	Photographic and Imaging Manufacturers Association
PSF	point spread function
PTB	Physikalisch-Technische Bundesanstalt (Federal Physical Technical Institute [Germany])
SAE	Society of Automotive Engineers
SI	Système International d'Unités (International System of Units)
SID	Society for Information Display
SMPTE	Society of Motion Picture and Television Engineers
SPIE	International Society for Optical Engineering (Society of Photo-Optical Instrumentation Engineers)
SSI	Swedish National Institute of Radiation Protection
STN	super twisted nematic (liquid crystal)
TAG	technical advisory group
TC	technical committee
TEPAC	Tube Engineering Panel Advisory Council (for EIA)
TEB	TEPAC Engineering Bulletin
TEP	Tube Engineering Panel
TFT	thin film transistor
TN	twisted nematic (liquid crystal)
USDC	United States Display Consortium
USNC	US National Committee of the IEC
VESA	Video Electronics Standards Association (vee'-suh)
VDT	video display terminal
VDU	video display unit
WG	working group



## A400 REFERENCES

In order to accommodate the buffet idea and keep future editions compatible with older documents, the numbering system of the references is not in order from front to back in the document. The first group are references used throughout the document. The listed references within section numbers are presented here for completeness.

- [1] EIAJ (Electronics Industries Association of Japan), Measuring Methods for Matrix Liquid Crystal Display Modules (Japanese), contact via [www.eiaj.or.jp](http://www.eiaj.or.jp).
- [2] ISO 13406 Part 2, "Ergonomic Requirements for the Use of Flat Panel Displays," ISO/TC 159/SC 4/WG 2, to be published (becoming a DIS at the time of this writing). See reference [3] for contact information.
- [3] ISO 9241 series: Ergonomic requirements for office work with visual display terminals (VDTs). Contact ISO: [www.iso.ch/infoc/guide.html](http://www.iso.ch/infoc/guide.html) for specific ordering information. Here are the three of interest to display metrologists (TC 159 / SC 4): Part 3 – Visual display requirements, Part 7- Requirements for display with reflection, Part 8 – Requirements for displayed colours. ISO documents are ordered through the member bodies for each participating country. For example, in the USA people would use ANSI (American National Standards Institute), 11 West 42nd Street, 13th floor, New York, N.Y. 10036, Telephone: + 1 212 642 49 00, Telefax: + 1 212 398 00 23, Internet: [info@ansi.org](mailto:info@ansi.org).
- [4] NIDL Publication No. 171795-036, Display Monitor Measurement Methods under Discussion by EIA (Electronic Industries Association) Committee JT-20, **Part 1: Monochrome CRT Monitor Performance**, Draft Version 2.0, July 12, 1995. NIDL Publication No. 171795-037, Display Monitor Measurement Methods under Discussion by EIA (Electronic Industries Association) Committee JT-20, **Part 2: Color CRT Monitor Performance**, Draft Version 2.0, July 12, 1995. These documents provided some of the ideas employed in this FPDM standard.
- [5] SMPTE Standard 170M-1994 "Televisoin – Composite Analog Video Signal – NTSC for Studio Applications," 595 W. Hartsdale Ave., White Plains, NY 10607-1824 U.S.A, tel: +1 914 761 1100 / fax: +1 914 761 3115, e-mail: [smpte@smpte.org](mailto:smpte@smpte.org).
- [6] CIE Publication No. 69, *Methods of Characterizing Illuminance and Luminance Meters*, Section 3.4.2.4 L "Measurement of the effect of the surrounding field." pp. 16-17.
- [7] Günter Wyszecki and W. S. Stiles, *Color Science: Concepts and Methods, Quantitative Data and Formulae*, 2<sup>nd</sup> Edition (1982, John Wiley & Sons). This is a classic reference work packed with information.
- [8] Peter A. Keller, *Electronic Display Measurement: Concepts, Techniques, and Instrumentation* (John Wiley & Sons in association with the Society for Information Display, 1997). This book contains a great deal of valuable reference material, tutorial material, numerous references to the literature and existing standards, descriptions of how things work, standards organizations, where to get things, as well as measurement techniques.
- [9] *Flat-Panel Displays and CRTs* (Van Nostrand Reinhold, New York, 1985) Lawrence T. Tannas, Jr., editor,. This book contains tutorial material, many references, comparisons of different technologies and how they work, discussion on the visual system and colorimetry, image quality, etc.
- [10] Yoshihiro Ohno, *Photometric Calibrations*, NIST Special Publication 250-37, U.S. Department of Commerce, National Institute of Standards and Technology, July 1997. This publication contains the details on how calibrations are made in photometry and describes the subtleties in the use of the instrumentation with a complete uncertainty analysis.
- [11] International Lighting Vocabulary, CIE Publication 17.4 (1989).
- [12] Barry N. Taylor, *Guide for the Use of the International System of Units (SI)*, NIST Special Publication 811, 1995 Edition. Also see ISO's Standards Handbook *Quantities and units* (International Organization for Standardization, Geneva, Switzerland, 1993).
- [13] ASTM Standards on Color and Appearance Measurement, 5<sup>th</sup> edition, 1996.
- [14]. C. S. McCamy, H. Marcus, and J. G. Davidson, "A Color Rendition Chart," *Journal of Applied Photographic Engineering*, Summer Issue, 1976, Vol. 2, No. 3, pp. 95-99.

## 305 TEMPORAL PERFORMANCE

P. Wolf and R. Goosses, Relation of photosensitivity to epileptic syndromes, *J. Neurol., Neurosurg., and Psychiat.* 49, 1386-1391 (1986)

## A201 PHOTOMETRY AND COLORIMETRY SUMMARY

- [1] P. Lennie, J. Pokorny, and V. C. Smith, Luminance, *J. Opt. Soc. Am. A*, Vol. 10 (1993), pp. 1283-1293
- [2] H. Fairman, M. Brill, & H. Hemmendinger, *Color Res. Appl.* 22 (1997), 11-23.
- [3] S. McCamy, *Color Res. Appl.* 17 (1992), pp. 142-144 (with erratum in *Color Res. Appl.* 18 [1993], p. 150).
- [4] A. Robertson, *J. Opt. Soc. Am.* 58 (1968), 1528-1535.
- [5] W.N. Sproson, *Colour Science in Television and Display Systems*, Adam-Hilger, 1983, page 42.
- [6] P. Alessi, *Color Res. Appl.* 19 (1994), 48-58.

## A209 NONLINEAR RESPONSE OF EYE

C. A. Poynton, *SMPTE Journal*, December 1993, p. 1101

## A217 REFLECTION MODELS

- [1] F. E. Nicodemus, J. C. Richmond, J. J. Hsia, I. W. Ginsberg, and T. Limperis, *Geometrical Considerations and Nomenclature for Reflectance*, NBS Monograph 160, October 1977.
- [2] ASTM Standards on Color and Appearance Measurement, 5<sup>th</sup> edition, E 284-95a, "Standard Terminology of Appearance," definition of haze, p. 243, 1996.
- [3] ASTM Standards on Color and Appearance Measurement, 5<sup>th</sup> edition, D 4449-90 (Reapproved 1995), "Standard Test Method for Visual Evaluation of Gloss Differences Between Surfaces of Similar Appearance," pp. 178-182, 1996. This discusses distinctness-of-image gloss and reflection haze.
- [4] ASTM Standards on Color and Appearance Measurement, 5<sup>th</sup> edition, E 179-91a, "Standard Guide for Selection of Geometric Conditions for Measurement of Reflection and Transmission Properties of Materials," pp. 210-215, 1996.
- [5] ASTM Standards on Color and Appearance Measurement, 5<sup>th</sup> edition, E 1392-90, "Standard Practice for Angle Resolved Optical Scatter Measurements on Specular or Diffuse Surfaces," pp. 439-444, 1996. Refers also to [6].
- [6] ASTM Standards on Color and Appearance Measurement, 5<sup>th</sup> edition, E 167-91, "Standard Practice for Goniophotometry of Objects and Materials," pp. 206-209, 1996.
- [7] M. E. Becker, "Evaluation and Characterization of Display Reflectance," Society for Information Display International Symposium, Boston Massachusetts, May 12-15, 1997, pp 827-830.
- [8] J. C. Stover, *Optical Scattering, Measurement and Analysis*, SPIE Optical Engineering Press, Bellingham, Wash., USA, 1995.

## A220 MEASURES OF CONTRAST—A TUTORIAL

- [1] R. N. Bracewell (1978), *The Fourier Transform and its Applications*. Second Ed. New York: McGraw-Hill.
- [2] J. W. Cooley and J. W. Tukey (1965), *Math. Comput.* 19, 297-301.
- [3] T. Cornsweet (1970), *Visual Perception*, Academic Press, pp. 312-330.
- [4] Electronic Industries Association (EIA, 1990). MTF Test Method for Monochrome CRT Display Systems, TEPAC Publication TEP105-17.
- [5] B. A. Wandell (1995), *Foundations of Vision*. Sunderland, MA: Sinauer; Chapter 2.
- [6] R. M. Boynton (1966), Vision, in Sidowski, J. B. (Ed.), *Experimental Methods and Instrumentation in Psychology*. McGraw-Hill, 1966.

## A221 STATEMENTS OF UNCERTAINTY

- [1] Barry N. Taylor and Chris E. Kuyatt, *Guidelines for Evaluating and Expressing the Uncertainty of NIST Measurement Results*, NIST Technical Note 1297, 1994 Edition.
- [2] *ISO Guide to the Expression of Uncertainty in Measurement*, (International Organization for Standardization), 1995.
- [3] ANSI/NCSL Z540-2-1997 *U.S. Guide to the Expression of Uncertainty in Measurement*, (American National Standards Institute/National Conference of Standards Laboratories), first edition, October 9, 1997.



## A222 PROCEDURE FOR VERIFYING DIGITALLY DRIVEN COLOR MONITORS

- [1] Commission Internationale de l'Eclairage (CIE), Method of Measuring and Specifying Colour Rendering Properties of Light Sources (Second Edition), *Publication CIE 13.2*, Bureau Central de la CIE, 1974.
- [2] G. Wyszecki and W. S. Stiles, *Color Science*, First ed., Wiley, 1967.
- [3] Commission Internationale de l'Eclairage (CIE), Colorimetry (Second Edition), *Publication CIE 15.2*, Bureau Central de la CIE, 1986.
- [4] G. Wyszecki and W. S. Stiles, *Color Science*, 2nd ed., Wiley, 1982.
- [5] Proposed SMPTE Standard for Television--Color Reference Pattern, *J. SMPTE*, September 1997, pp. 643-649.
- [6] C. S. McCamy, H. Marcus, and J. G. Davidson, "A Color Rendition Chart," *Journal of Applied Photographic Engineering*, Summer Issue, 1976, Vol. 2, No. 3, pp. 95-99.

## GLOSSARY:

- [1] J. Lubin, A visual system discrimination model for imaging system design and evaluation, in E. Peli (ed.), *Visual Models for Target Detection and Recognition*, World Scientific Publishers, 1995.
- [2] J. Lubin, M. Brill, and R. Crane, Vision model-based assessment of distortion magnitudes in digital video, presented at the November, 1996 meeting of the International Association of Broadcasters (IAB).





# A500 TABLES AND FORMULAS

Here are copies of some of the more useful tables and formulas found in this document. The originating section number appears before the table caption as appropriate.

### CONVERSION OF ANGLES IN RADIANES TO OR FROM DEGREES

$$q \text{ (in degrees)} = \frac{360^\circ q \text{ (in radians)}}{2\pi} = 57.2958q \text{ (in radians)}$$

$$q \text{ (in radians)} = \frac{2\pi q \text{ (in degrees)}}{360^\circ} = 0.0174533q \text{ (in degrees)}$$

$$\left\{ \begin{array}{l} q = \text{angle expressed in degrees or radians} \\ \pi = 3.1415927\dots = 4 \arctan(1), \text{ (arctan in radians)} \end{array} \right.$$

### SUBTENSE ANGLE OF THE LENS OF THE LMD

$$q_L = 360^\circ \frac{D_L}{2\pi z}, \quad \left\{ \begin{array}{l} q_L = \text{subtense angle in degrees of the lens of the LMD as viewed from the screen} \\ D_L = \text{diameter of the region of the lens that gathers light (entrance pupil)} \\ z = \text{distance from screen} \end{array} \right.$$

### Converting photometric units:

Suppose you need to have the luminance expressed in  $\text{cd/m}^2$  but it is given to you in  $\text{fL}$ , you have the table below, but get confused as to how to use it. Here is a simple way: Multiply by one, where the denominator has the unit that you want to eliminate and the numerator has the unit you want to use. Thus, if you're given a screen luminance as  $37.5 \text{ fL}$  and you want SI units...multiply by one...

$$37.5 \text{ fL} * 1 = 37.5 \text{ fL} * 3.4263 \frac{\text{cd/m}^2}{\text{fL}} = 128 \text{ cd/m}^2$$

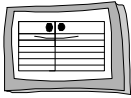
Similarly, given an illuminance of  $24.9 \text{ fc}$ , what is the illuminance in lux? ... multiply by one...

$$24.9 \text{ fc} = 24.9 \text{ fc} * 1 = 24.9 * 10.76 \frac{\text{lx}}{\text{fc}} = 268 \text{ lx},$$

and so forth.

SI (Metric) and English Photometric Conversion Table				
↓ = ### * →	$\text{cd/m}^2 = \text{lm/sr/m}^2$	$\text{fL} = \text{lm/sr/ft}^2$	$\text{lx} = \text{lm/m}^2$	$\text{fc} = \text{lm/ft}^2$
<b>1 <math>\text{cd/m}^2 = 1 \text{ lm/sr/m}^2</math></b>	1	0.2919		
<b>1 <math>\text{fL} = 1 \text{ lm/sr/ft}^2</math></b>	3.4263	1		
<b>1 <math>\text{lx} = 1 \text{ lm/m}^2</math></b>			1	0.09290
<b>1 <math>\text{fc} = 1 \text{ lm/ft}^2</math></b>			10.76	1
origin of number:	$\text{m}^2/\pi/\text{ft}^2 = 3.426259\dots$	$\pi\text{ft}^2/\text{m}^2 = 0.2918635\dots$	$\text{m}^2/\text{ft}^2 = 10.76391\dots$	$\text{ft}^2/\text{m}^2 = 0.09290304\dots$
<b>1 = →</b>	$3.4263 \frac{\text{cd/m}^2}{\text{fL}}$	$0.2919 \frac{\text{fL}}{\text{cd/m}^2}$	$10.76 \frac{\text{lx}}{\text{fc}}$	$0.09290 \frac{\text{fc}}{\text{lx}}$

TABLES



<b>300 OPTICAL: Table 1a. Coordinate transformations.</b>			
$\text{asin } q \equiv \arcsin q \equiv \sin^{-1} q, \text{acos } q \equiv \arccos q \equiv \cos^{-1} q, \text{atan } q \equiv \arctan q \equiv \tan^{-1} q, 0 \leq q \leq \pi/2$			
$\downarrow = \rightarrow$	Horizontal and Vertical Viewing Angle $q_H, q_V = \text{Hor., Ver.}$	North Polar $n_H, n_V = \text{Hor., Ver.}$ (Independent Axis Vertical)	East Polar $e_H, e_V = \text{Hor., Ver.}$ (Independent Axis Horizontal)
Cartesian (Fig. 1) $x, y, z$	$x = r \sin q \cos f$ $y = r \sin q \sin f$ $z = r \cos q$ Use $q, f$ as below.	$x = r \sin n_H \cos n_V$ $y = r \sin n_V$ $z = r \cos n_H \cos n_V$	$x = r \sin e_H$ $y = r \cos e_H \sin e_V$ $z = r \cos e_H \cos e_V$
Spherical (Fig. 2) $q, f$	$q = \text{atan} \sqrt{\tan^2 q_H + \tan^2 q_V}$ $f = \text{atan}(\tan q_V / \tan q_H)$	$q = \text{acos}(\cos n_V \cos n_H)$ $f = \text{atan}(\tan n_V / \sin n_H)$	$q = \text{acos}(\cos e_V \cos e_H)$ $f = \text{atan}(\sin e_V / \tan e_H)$
H&V Viewing Angle (Fig. 3) $q_H, q_V$	1	$q_H = n_H$ $q_V = \text{atan}(\tan n_V / \cos n_H)$	$q_H = \text{atan}(\tan e_H / \cos e_V)$ $q_V = e_V$
North Polar (Fig. 4) $n_H, n_V$	$n_H = q_H$ $n_V = \text{atan}(\tan q_V \cos q_H)$	1	$n_H = \text{atan}(\tan e_H / \cos e_V)$ $n_V = \text{asin}(\cos e_H \sin e_V)$
East Polar (Fig. 5) $e_H, e_V$	$e_H = \text{atan}(\tan q_H \cos q_V)$ $e_V = q_V$	$e_H = \text{asin}(\cos n_V \sin n_H)$ $e_V = \text{atan}(\tan n_V / \cos n_H)$	1

<b>300 OPTICAL: Table 1b. Coordinate transformations .</b>		
$\downarrow = \rightarrow$	Cartesian $x, y, z$ $r = \sqrt{x^2 + y^2 + z^2}$	Spherical $q, f$
Cartesian (Fig. 1) $x, y, z$	1	$x = r \sin q \cos f$ $y = r \sin q \sin f$ $z = r \cos q$
Spherical (Fig. 2) $q, f$	$q = \text{acos}(z/r)$ $f = \text{atan}(y/x)$	1
H&V Viewing Angle (Fig. 3) $q_H, q_V$	$q_H = \text{atan}(x/z)$ $q_V = \text{atan}(y/z)$	$q_H = \text{atan}(\tan q \cos f)$ $q_V = \text{atan}(\tan q \sin f)$
North Polar (Fig. 4) $n_H, n_V$	$n_H = \text{atan}(x/z)$ $n_V = \text{asin}(y/r)$	$n_H = \text{atan}(\tan q \cos f)$ $n_V = \text{asin}(\sin q \sin f)$
East Polar (Fig. 5) $e_H, e_V$	$e_H = \text{asin}(x/r)$ $e_V = \text{atan}(y/z)$	$e_H = \text{asin}(\sin q \cos f)$ $e_V = \text{atan}(\tan q \sin f)$

TABLES



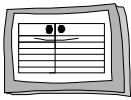
**300 OPTICAL: Table 2. Variables Used in This Document**

Abbreviations: **LMD** = light measuring device; **FOV** = field of view; **AFOV** = angular FOV; subpixel subscript *i* = red, blu, grn, for example; subscript *j* = bit or voltage level; **BRDF** = bidirectional reflectance distribution function; **CCD** = charge coupled device

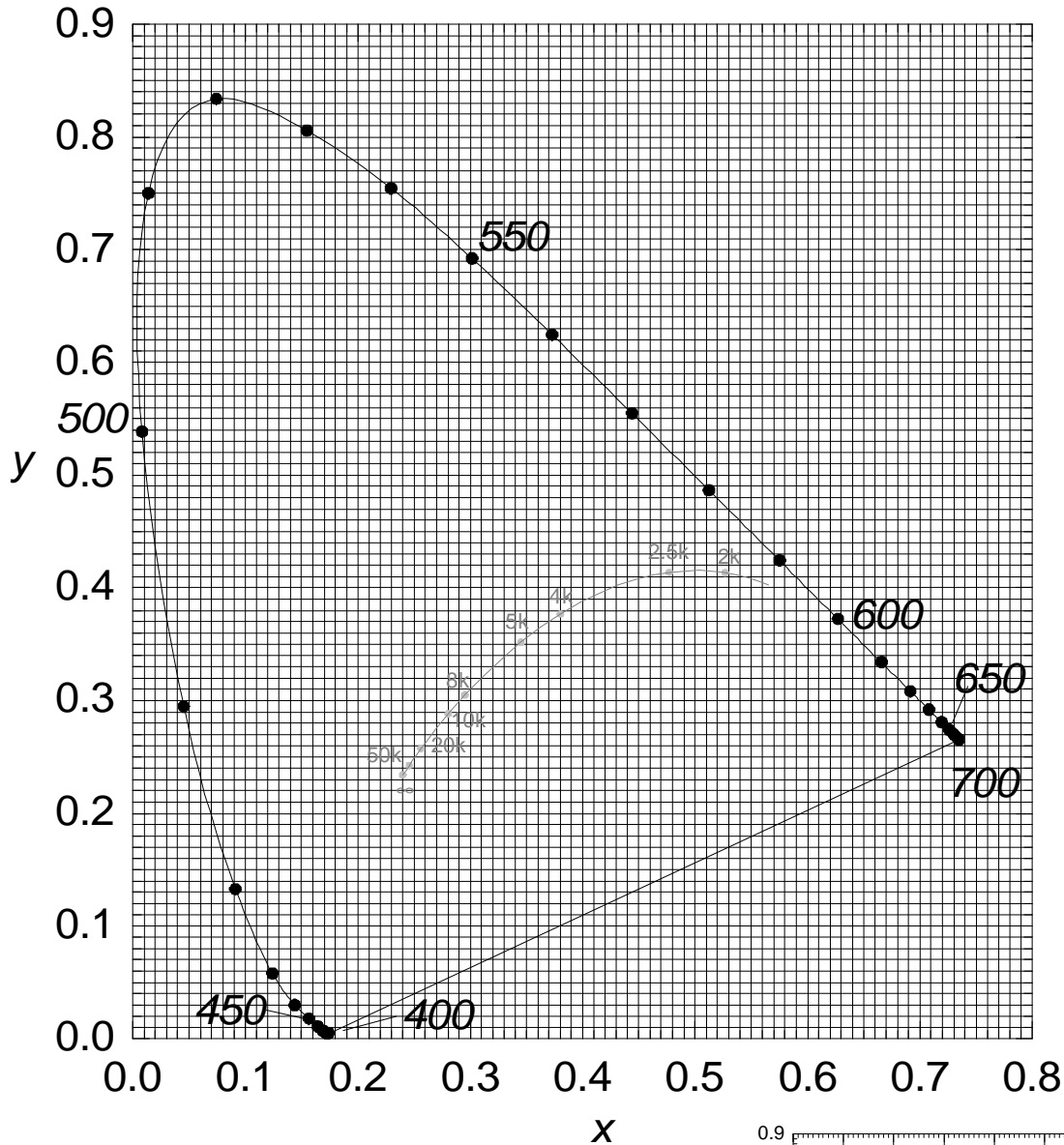
*Please Note: Throughout this document the screen or display surface refers to the visible pixel surface, only those pixels that contribute to the display of information. Any pixels behind a bezel are not included, neither is any border around the information-displaying surface included. The diagonal D is the measure of the diagonal of the viewable, information-displaying rectangular surface.*

Symbol	Description	Symbol	Description
<i>a</i>	aspect ratio ( $a = H/V$ )	$N_T$	total number of pixels ( $N_T = N_H \times N_V$ )
<i>a</i>	small area, or small area of the screen	$N_V$	number of pixels in the vertical dimensions
<i>A</i>	area	$\pi$	3.141592653... = 4arctan(1)
<i>B</i>	BRDF	<i>P</i>	square pixel pitch (distance per pixel), power in watts (W), pressure
<i>C</i>	contrast ( $C_R$ = contrast ratio, $C_m$ = Michelson contrast, etc.)	$P_H$	horizontal pixel pitch
<i>D</i>	diagonal measure of viewable display , density	$P_V$	vertical pixel pitch
$d_a$	diameter of small area, target, or FOV	<i>Q</i>	Cluster defect dispersion quality (1/cluster density)
$n_H, n_V$ $e_H, e_V$	north-polar and east-polar goniometer angles	<i>R</i>	refresh rate, radius
<i>h</i>	luminous efficiency	<i>r, r_a</i>	radius, radius of round small area on the screen
<i>e</i>	frontal luminance efficiency	$s_i, s$	subpixel areas, small areas, distances
<i>E</i>	illuminance ( $lx = lm/m^2$ )	<i>S</i>	surface areas; signal level, or signal counts (as with using a CCD); also square pixel spatial frequency (pixels per unit distance, $S = 1/P$ )
<i>f</i>	fractional fill-factor threshold luminance	$S_H$	horizontal pixel spatial frequency
$f_a$	fractional (or percent) area of the screen for small area, target, or FOV	$S_V$	vertical pixel spatial frequency
<i>F</i>	luminous flux (lm)	<i>q, f</i>	spherical coordinates (see 300)
<i>H</i>	horizontal size of the screen.	$q_H, q_V$	horizontal, vertical viewing angles
<i>g</i>	gamma exponent in nonlinear fit (302-5)	$q_F$	AFOV of LMD
<i>I</i>	luminous intensity (cd = lm/sr)	$T_C$	correlated color temperature
<i>k</i>	detector conversion A/lm	$V, V_j$	vertical screen size, voltage, gray-scale levels
$K_i$	peak luminances of pixel subpixels	<i>W</i>	weight
<i>l</i>	Wavelength	$W, w$	Solid angle
<i>L</i>	luminance ( $cd/m^2$ )	<i>x, y, z</i>	Cartesian right-handed coordinate system with <i>z</i> perpendicular to the screen, <i>x</i> horizontal, <i>y</i> vertical
$L^*$	Lightness metric in CIELUV and CIELAB color spaces (see A201)	$u', v'$	1976 CIE chromaticity coordinates
<i>m</i>	mass	<i>u, v</i>	1960 CIE chromaticity coordinates (for CCT determinations)
<i>M</i>	luminous exitance ( $lx = lm/m^2$ )	$x, y, z$	1931 CIE chromaticity coordinates
$N_a$	number of pixels covered by a small area <i>a</i>	$X, Y, Z$	1931 CIE tristimulus values
$N_H$	number of pixels in horizontal dimension	$\bar{x}, \bar{y}, \bar{z}$	1931 CIE color matching functions

TABLES



CIE 1931 (x, y)



TABLES

$$x = \frac{X}{X+Y+Z}$$

$$y = \frac{Y}{X+Y+Z}$$

$$z = \frac{Z}{X+Y+Z}$$

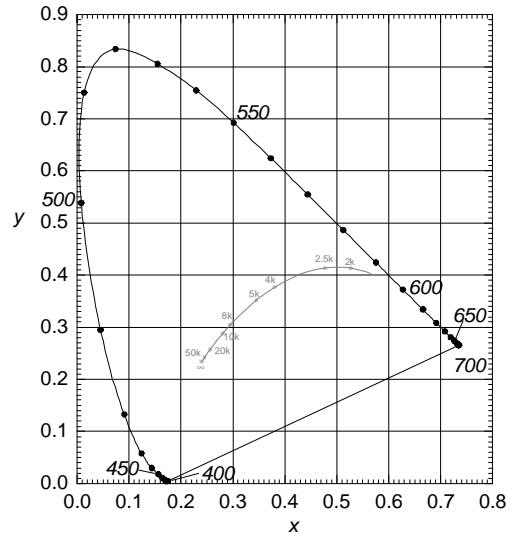
$$x + y + z = 1$$

$$X = \frac{x}{y} Y$$

Y = luminous flux

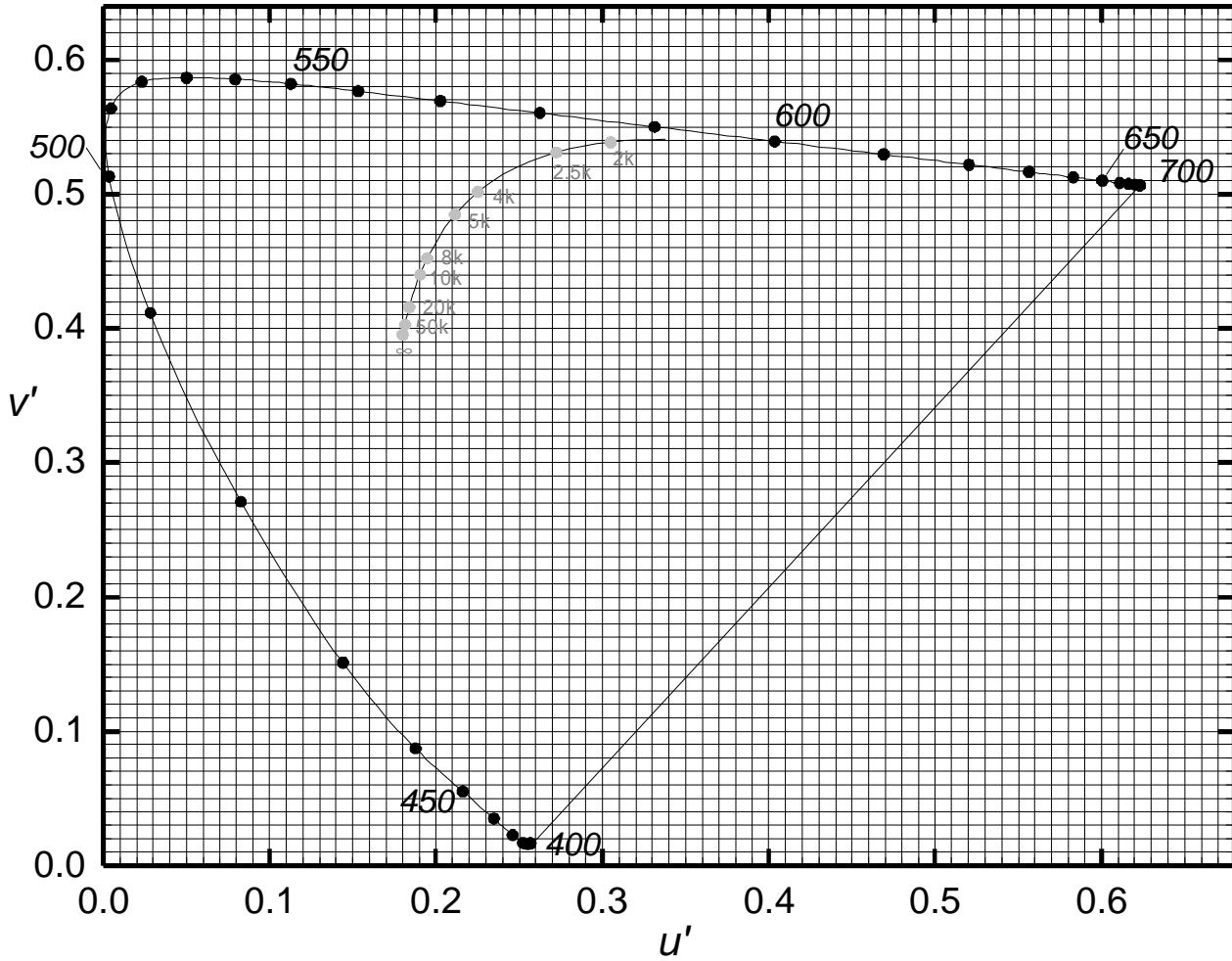
$$Z = \frac{z}{y} Y$$

Interior curve is Planckian locus in thousands of kelvins.





**CIE 1976 ( $u'$ ,  $v'$ )**

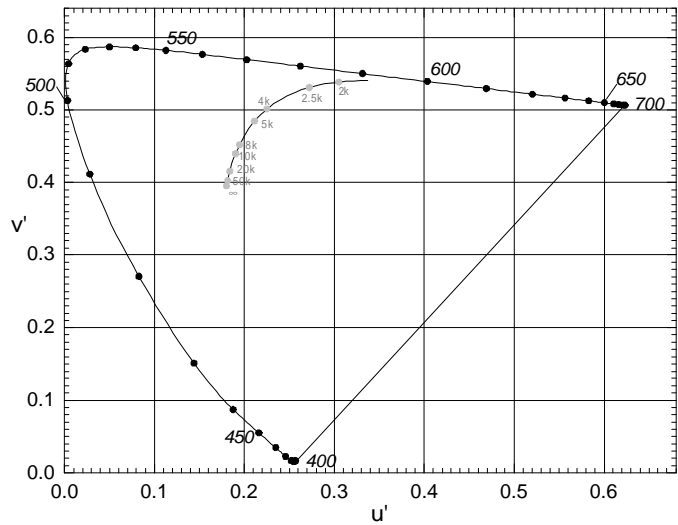


$$u' = \frac{4X}{X + 15Y + 3Z} \quad \left( = \frac{4x}{3 + 12y - 2x} \right)$$

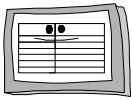
$$v' = \frac{9Y}{X + 15Y + 3Z} \quad \left( = \frac{9y}{3 + 12y - 2x} \right)$$

$$\Delta u'v' = \sqrt{(u'_1 - u'_2)^2 + (v'_1 - v'_2)^2}$$

Interior curve is Planckian locus in thousands of kelvins.



TABLES



501-1 SIZE: Table 3. Summary of useful relationships between size variables.																	
Some equations are only true for square pixels. See Table 4 for definitions.																	
Expression	Square Pixels ?	$N_H$	$N_V$	$N_T$	$H$	$V$	$A$	$P_H$	$P_V$	$P$	$S_H$	$S_V$	$S$	$a$	$D$	$a$	Comments
$A = HV$					*	*	*										
$H = N_H P_H$		*			*			*									Very small error
$H = \frac{D}{\sqrt{\left(\frac{N_V}{N_H}\right)^2 + 1}}$	Sq. px Only	*	*		*											*	
$H = \frac{aD}{\sqrt{a^2 + 1}}$	Sq. px Only				*											*	Aspect ratio may not be known accurately due to rounding.
$V = N_V P_V$			*			*			*								Very small error
$V = \frac{D}{\sqrt{\left(\frac{N_H}{N_V}\right)^2 + 1}}$	Sq. px Only	*	*			*										*	
$V = \frac{D}{\sqrt{a^2 + 1}}$	Sq. px Only					*										*	Aspect ratio may not be known accurately due to rounding.
$a = P_H P_V$								*	*							*	
$a = P^2$	Sq. px Only									*						*	
$a = A/N_T$				*			*									*	
$D = \sqrt{H^2 + V^2}$					*	*										*	
$D = \sqrt{(P_H N_H)^2 + (P_V N_V)^2}$		*	*					*	*							*	
$D = \sqrt{P_2(N_H^2 + N_V^2)}$	Sq. px Only	*	*							*						*	
$D = \sqrt{\left(\frac{N_H}{S_H}\right)^2 + \left(\frac{N_V}{S_V}\right)^2}$		*	*								*	*				*	
$D = \sqrt{N_H^2 + N_V^2} / S$	Sq. px Only	*	*										*			*	
$P = \frac{D}{\sqrt{N_H^2 + N_V^2}}$	Sq. px Only	*	*							*						*	
$a = H/V$					*	*										*	
$a = N_H / N_V$	Sq. px Only	*	*													*	

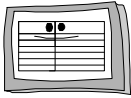
501-1 SIZE: Table 4. Variables Related to Size.	
$P_H, P_V, P$	Pixel pitch for horizontal, vertical, and for square pixels for which $P_H = P_V = P$
$N_H, N_V$	Number of pixels in the horizontal and vertical direction
$S_H, S_V, S$	Pixel spatial frequency for horizontal, vertical, and for square pixels ( $S = 1/P$ )
$D$	Diagonal measure of the screen, expressed in units of distance
$H, V$	Horizontal and vertical measure of the screen
$a$	Aspect ratio $a = H/V$
$A$	Area of viewable display surface ( $A = HV$ )
$a$	Rectangular area allocated to each pixel ( $a = P_H P_V$ )



Aspect-Ratio Conversion Table							
Decimal aspect ratios less than 5:1 converted to integer ratios using integer numbers no greater than 20.							
Ratios in parentheses are some equivalent aspect ratios sometimes used in industry.							
Decimal Aspect Ratio	Integer Aspect Ratio	Decimal Aspect Ratio	Integer Aspect Ratio	Decimal Aspect Ratio	Integer Aspect Ratio	Decimal Aspect Ratio	Integer Aspect Ratio
1	1 : 1	1.2727...	14 : 11	1.7143...	12 : 7	2.6	13 : 5
1.0526...	20 : 19	1.2857...	9 : 7	1.7273...	19 : 11	2.6667...	8 : 3
1.0556...	19 : 18	1.3	13 : 10	1.75	7 : 4	2.7143...	19 : 7
1.0588...	18 : 17	1.3077...	17 : 13	1.7778...	16 : 9	2.75	11 : 4
1.0625...	17 : 16	1.3333...	4 : 3 (8:6)	1.8	9 : 5 (18:10)	2.8	14 : 5
1.0667...	16 : 15	1.3571...	19 : 14	1.8182...	20 : 11	2.8333...	17 : 6
1.0714...	15 : 14	1.3636...	15 : 11	1.8333...	11 : 6	2.8571...	20 : 7
1.0769...	14 : 13	1.375	11 : 8	1.8571...	13 : 7	3	3 : 1
1.0833...	13 : 12	1.3846...	18 : 13	1.875	15 : 8	3.1667...	19 : 6
1.0909...	12 : 11	1.4	7 : 5 (14:10)	1.8889...	17 : 9 (34:18)	3.2	16 : 5
1.1	11 : 10	1.4167...	17 : 12	1.9	19 : 10 (9.5:5)	3.25	13 : 4
1.1111...	10 : 9	1.4286...	10 : 7	2	2 : 1 (20:10)	3.3333...	10 : 3
1.1176...	19 : 17	1.4444...	13 : 9 (26:18)	2.1111...	19 : 9	3.4	17 : 5
1.1333...	17 : 15	1.4545...	16 : 11	2.125...	17 : 8	3.5	7 : 2
1.1429...	8 : 7	1.4615...	19 : 13	2.1429...	15 : 7	3.6	18 : 5
1.1538...	15 : 13	1.5	3 : 2 (6:4)	2.1667...	13 : 6	3.6667...	11 : 3
1.1667...	7 : 6	1.5385...	20 : 13	2.2	11 : 5	3.75	15 : 4
1.1765...	20 : 17	1.5455...	17 : 11	2.2222...	20 : 9	3.8	19 : 5
1.1818...	13 : 11	1.5556...	14 : 9 (28:18)	2.25	9 : 4	4	4 : 1
1.1875...	19 : 16	1.5714...	11 : 7	2.2857...	16 : 7	4.25	17 : 4
1.2	6 : 5 (12:10)	1.5833...	19 : 12	2.3333...	7 : 3	4.3333...	13 : 3
1.2143...	17 : 14	1.6	8 : 5 (16:10)	2.375	19 : 8	4.5	9 : 2
1.2222...	11 : 9 (22:18)	1.625	13 : 8	2.4286...	17 : 7	4.6667...	14 : 3
1.2308...	16 : 13	1.6364...	18 : 11	2.4	12 : 5	4.75	19 : 4
1.25	5 : 4 (10:8)	1.6667...	5 : 3	2.5	5 : 2	5	5 : 1
1.2667...	19 : 15	1.7	17 : 10 (8.5:5)	2.5714...	18 : 7		

1:1
6:5
5:4
4:3
7:5
3:2
8:5
16:9
2:1
5:2
3:1
4:1
5:1

TABLES



The following equations and table are from 301-2h (Viewing Distance, Angle, and Angular Field of View) and A102-1 (Minimum Measured Region of Display Surface).

FOR SQUARE PIXELS

$$N = \frac{s}{a} = N_T \frac{s}{A} = \frac{\pi r^2}{HV} N_T = \frac{\pi r^2}{P^2}, \text{ or}$$

$$N = \pi \left[ \frac{z \tan(q/2)}{D} \right]^2 (N_H^2 + N_V^2), \text{ or}$$

$$N \cong \frac{\pi}{4} d^2 \frac{(N_H^2 + N_V^2)}{D^2},$$

(where in the last equation it is assumed that  $z \gg r$ )

- A = area of the screen (viewable area, of course)
- $N_{H,V}$  = number of pixels, horizontal, vertical
- $P_H, P_V$  = pixel pitch in the horizontal/vertical direction
- P = pixel pitch for square pixels
- H = horizontal size of screen =  $N_H P_H = N_H P$  (for square pixels)
- V = vertical size of screen =  $N_V P_V = N_V P$  (for square pixels)
- r = radius of round measurement area on screen
- s = area of screen being measured =  $\pi r^2$  (Goal:  $s < A/100$ )
- d =  $2r$  = diameter of round measurement area on screen  
(should be less than 10% of H and V)
- a = area allocated to one pixel =  $P_H P_V$  (=  $P^2$  for square pixels)
- $N_T$  = total number of pixels on the screen =  $N_H N_V$
- N = number of pixels being measured on the screen (Goal: 500 px)
- z = distance from the screen to the LMD
- D = diagonal =  $\sqrt{H^2 + V^2} = P \sqrt{N_H^2 + N_V^2}$   
Note that D is the exact diagonal of the viewable display surface.
- q = LMD angular field of view ( $^\circ$  or rad:  $^\circ = \text{rad} \cdot 360^\circ/2\pi$ )  
(NOTE: for small angles  $< 10^\circ$ ,  $\sin q \cong \tan q \cong q$  within 1%,  
where  $q \cong d/z$  must be in radians)

$$z = \sqrt{\frac{NP_H P_V}{\pi \tan^2(q/2)}}, \text{ where } \begin{cases} N = \text{number of pixels measured on screen} \\ z = \text{distance from screen to LMD} \\ P_{H,V} = \text{pixel pitch, horizontal, vertical} \\ q = \text{LMD angular field of view } (^\circ, \text{ or rad: } ^\circ = \text{rad} \cdot 360^\circ/2\pi) \end{cases}$$

TABLES



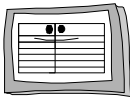
**Table 1. Number of Pixels Measured and Percent of Screen Diagonal Measured for Several Configurations.**

Dec.=decimal, No.=number of,  $z$  = distance between DUT and LMD,  $q$  = AFOV,  $a$  = aspect ratio,  $D$  = diagonal

The shaded area denotes failure to comply with 500-pixel and  $\leq 10\%$ -of-diagonal convention.

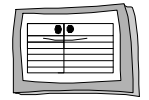
Display Pixels		Diagonal		$z$ (mm)	$q$ ( $^\circ$ )	Aspect Ratio $a$		Size of Screen				Measurement Region		No. pixels $N$	
$N_H$	$N_V$	(in)	(mm)			Dec.	Ratio	$H$ (in)	$V$ (in)	$H$ (mm)	$V$ (mm)	$d = 2r$ (mm)	in % of $D$		% Area
640	480	10.4	264	500	2	1.333	4:3	8.32	6.24	211	158	17.46	<b>6.6%</b>	0.71%	<b>2195</b>
640	480	21.0	533	500	2	1.333	4:3	16.80	12.60	427	320	17.46	<b>3.3%</b>	0.18%	<b>538</b>
640	480	21.0	533	500	1	1.333	4:3	16.80	12.60	427	320	8.73	<b>1.6%</b>	0.04%	<b>135</b>
640	480	21.0	533	500	2	1.333	4:3	16.80	12.60	427	320	17.46	<b>3.3%</b>	0.18%	<b>538</b>
640	480	5.2	132	500	2	1.333	4:3	4.16	3.12	106	79	17.46	<b>13.2%</b>	2.86%	<b>8779</b>
640	480	5.2	132	500	1	1.333	4:3	4.16	3.12	106	79	8.73	<b>6.6%</b>	0.71%	<b>2194</b>
640	480	32.0	813	500	2	1.333	4:3	25.60	19.20	650	488	17.46	<b>2.1%</b>	0.08%	<b>232</b>
800	600	11.3	287	500	2	1.333	4:3	9.04	6.78	230	172	17.46	<b>6.1%</b>	0.61%	<b>2905</b>
800	600	15.0	381	500	2	1.333	4:3	12.00	9.00	305	229	17.46	<b>4.6%</b>	0.34%	<b>1648</b>
800	600	22.6	574	500	2	1.333	4:3	18.08	13.56	459	344	17.46	<b>3.0%</b>	0.15%	<b>726</b>
1024	768	12.1	307	500	2	1.333	4:3	9.68	7.26	246	184	17.46	<b>5.7%</b>	0.53%	<b>4151</b>
1024	768	15.0	381	500	2	1.333	4:3	12.00	9.00	305	229	17.46	<b>4.6%</b>	0.34%	<b>2701</b>
1024	768	6.4	163	500	2	1.333	4:3	5.12	3.84	130	98	17.46	<b>10.7%</b>	1.89%	<b>14836</b>
1024	768	6.4	163	500	1	1.333	4:3	5.12	3.84	130	98	8.73	<b>5.4%</b>	0.47%	<b>3709</b>
1024	768	21.0	533	500	2	1.333	4:3	16.80	12.60	427	320	17.46	<b>3.3%</b>	0.18%	<b>1378</b>
1280	1024	13.0	330	500	2	1.250	5:4	10.15	8.12	258	206	17.46	<b>5.3%</b>	0.45%	<b>5897</b>
1280	1024	25.0	635	500	2	1.250	5:4	19.52	15.62	496	397	17.46	<b>2.7%</b>	0.12%	<b>1595</b>
1280	1024	17.0	432	500	2	1.250	5:4	13.27	10.62	337	270	17.46	<b>4.0%</b>	0.26%	<b>3449</b>
1280	1024	42.0	1067	500	2	1.250	5:4	32.80	26.24	833	666	17.46	<b>1.6%</b>	0.04%	<b>565</b>
1280	1024	23.0	584	500	1	1.250	5:4	17.96	14.37	456	365	8.73	<b>1.5%</b>	0.04%	<b>471</b>
1280	1024	23.0	584	500	2	1.250	5:4	17.96	14.37	456	365	17.46	<b>3.0%</b>	0.14%	<b>1884</b>
1280	1024	60.0	1524	500	2	1.250	5:4	46.85	37.48	1190	952	17.46	<b>1.1%</b>	0.02%	<b>277</b>
1920	1080	17.0	432	500	2	1.778	16:9	14.82	8.33	376	212	17.46	<b>4.0%</b>	0.30%	<b>6228</b>
1920	1080	42.0	1067	500	2	1.778	16:9	36.61	20.59	930	523	17.46	<b>1.6%</b>	0.05%	<b>1020</b>
1920	1080	12.0	305	500	2	1.778	16:9	10.46	5.88	266	149	17.46	<b>5.7%</b>	0.60%	<b>12500</b>
3072	2240	13.5	343	500	2	1.371	11:8	10.91	7.95	277	202	17.46	<b>5.1%</b>	0.43%	<b>29418</b>

TABLES



A222 Table of Spectra  
Reference 2 (Wyszecki and Stiles, 1967)

Reference 1 (CIE Publication 13.2)		Reference 2 (Wyszecki and Stiles, 1967)														Daylight Eigenvectors			CIE 1931 Color Matching Functions				
λ	Munsell Colors						Munsell Colors						10 P		S <sub>0</sub>	S <sub>1</sub>	S <sub>2</sub>	xbar	ybar	zbar	λ		
	7.5 R 6/4	5 Y 6/4	5 GY 6/8	2.5 G 6/6	10 BG 6/4	5 PB 6/8	2.5 P 6/8	10 P 6/8	7.5 R 6/4	5 Y 6/4	5 GY 6/8	2.5 G 6/6	10 BG 6/4	5 PB 6/8								2.5 P 6/8	10 P 6/8
400	25.6	11.1	7.3	11.6	31.3	41	55.1	31.9	26.3	11.4	7.5	11.9	32.1	42	56.5	34.5	94.8	43.4	-1.1	0.014	4E-04	0.068	400
410	25.2	11.8	7.4	12.4	31.9	49.2	55.9	46.2	25.8	12.1	7.6	12.7	32.7	50.5	57.3	47.4	104.8	46.3	-0.5	0.044	0.001	0.207	410
420	24.4	12.1	7.4	12.8	32.6	51.7	56.1	49	25	12.4	7.6	13.1	33.4	53	57.5	50.2	105.9	43.9	-0.7	0.134	0.004	0.646	420
430	23.7	12.2	7.3	13.5	33.4	53.1	55.6	48.2	24.3	12.5	7.5	13.8	34.3	54.5	57	49.4	96.8	37.1	-1.2	0.284	0.012	1.386	430
440	23	12.3	7.3	14.4	34.6	54.4	54.4	46.2	23.6	12.6	7.5	14.8	35.5	55.8	55.8	47.4	113.9	36.7	-2.6	0.348	0.023	1.747	440
450	22.5	12.7	7.4	16.1	36	55.6	52.2	43.9	23.1	13	7.6	16.5	36.9	57	53.5	45	125.6	35.9	-2.9	0.336	0.038	1.772	450
460	22	13.1	7.7	18.6	38.1	55.4	48.8	41.3	22.6	13.4	7.9	19.1	39.1	56.8	50.1	42.4	125.5	32.6	-2.8	0.291	0.06	1.669	460
470	21.6	13.8	8.5	22.9	40.3	54.1	44.8	38.2	22.1	14.1	8.7	23.5	41.3	55.5	46	39.2	121.3	27.9	-2.6	0.195	0.091	1.288	470
480	21.4	15	10.9	28.1	41.5	51.9	40.8	35.2	22	15.4	11.2	28.8	42.6	53.2	41.8	36.1	121.3	24.3	-2.6	0.096	0.139	0.813	480
490	21.6	17.4	14.8	33.2	41.9	48.8	36.3	32.5	22.2	17.8	15.2	34	43	50	37.2	33.3	113.5	20.1	-1.8	0.032	0.208	0.465	490
500	22.3	20.7	19.8	37	41.3	45	32.4	29.9	22.9	21.2	20.3	37.9	42.4	46.2	33.2	30.7	113.1	16.2	-1.5	0.005	0.323	0.272	500
510	22.6	24.2	24.1	39	40.3	41.4	30.1	28.3	23.2	24.8	24.7	40	41.3	42.5	30.9	29	110.8	13.2	-1.3	0.009	0.503	0.158	510
520	22.5	26	27.8	39.5	38.9	37.7	28.3	27	23.1	26.7	28.5	40.5	39.9	38.7	29	27.7	106.5	8.6	-1.2	0.063	0.71	0.078	520
530	22.7	26.7	33.9	38.5	37.2	34.1	26.5	25.6	23.3	27.4	34.8	39.5	38.2	35	27.2	26.3	108.8	6.1	-1	0.166	0.862	0.042	530
540	23.6	27.2	39.2	36.7	35.3	30.9	25.7	25	24.2	27.9	40.2	37.6	36.2	31.7	26.4	25.6	105.3	4.2	-0.5	0.29	0.954	0.02	540
550	25.3	28.2	40	34.1	33.1	27.9	25.9	25.4	25.9	28.9	41	35	33.9	28.6	26.6	26	104.4	1.9	-0.3	0.433	0.995	0.009	550
560	27.2	29.9	38	31.2	30.8	25.3	26	26.4	27.9	30.7	39	32	31.6	25.9	26.7	27.1	100	0	0	0.595	0.995	0.004	560
570	29.8	32.2	34.9	28	28.4	23.4	25.6	27.2	30.6	33	35.8	28.7	29.1	24	26.3	27.9	96	-1.6	0.2	0.762	0.952	0.002	570
580	34.1	33.5	31.5	24.7	26	22.5	25.4	27.8	35	34.4	32.3	25.3	26.7	23.1	26.1	28.5	95.1	-3.5	0.5	0.916	0.87	0.002	580
590	39	34.1	28.5	21.4	23.2	22.1	27	29.5	40	35	29.2	21.9	23.8	22.7	27.7	30.3	89.1	-3.5	2.1	1.026	0.757	0.001	590
600	42.4	34.2	26.4	18.5	21	22	30.2	34.8	43.5	35.1	27.1	19	21.5	22.6	31	35.7	90.5	-5.8	3.2	1.062	0.631	8E-04	600
610	44.2	34.2	25.2	16.9	19.4	22	34.4	43.4	45.3	35.1	25.8	17.3	19.9	22.6	35.3	44.5	90.3	-7.2	4.1	1.003	0.503	3E-04	610
620	45	34.1	24.1	16	18.5	22.3	37.7	52.8	46.1	35	24.7	16.4	19	22.9	38.7	54.2	88.4	-8.6	4.7	0.854	0.381	2E-04	620
630	45.1	33.9	22.9	15.4	18	23.3	40	60.4	46.3	34.8	23.5	15.8	18.5	23.9	41	62	84	-9.5	5.1	0.642	0.265	0	630
640	45.1	33.8	22	15.1	17.6	24.4	42	64.8	46.3	34.7	22.6	15.5	18.1	25	43.1	66.5	85.1	-10.9	6.7	0.448	0.175	0	640
650	45	33.6	21.6	14.8	17.5	25.8	43.8	67.6	46.2	34.5	22.2	15.2	17.9	26.5	44.9	69.3	81.9	-10.7	7.3	0.284	0.107	0	650
660	45.1	33.4	21.9	14.8	17.5	26.8	45.2	69.3	46.3	34.3	22.5	15.2	17.9	27.5	46.4	71.1	82.6	-12	8.6	0.165	0.061	0	660
670	45.3	33.2	23	15.1	18	27.8	46.2	70.5	46.5	34.1	23.6	15.5	18.5	28.5	47.4	72.3	84.9	-14	9.8	0.087	0.032	0	670
680	45.5	33.1	25.1	15.8	18.6	28.3	46.8	71.2	46.7	33.9	25.7	16.2	19.1	29	48	73	81.3	-13.6	10.2	0.047	0.017	0	680
690	45.8	32.9	28.8	16.5	19.2	29.1	47.3	71.7	47	33.7	29.5	16.9	19.7	29.8	48.5	73.5	71.9	-12	8.3	0.023	0.008	0	690
700	46.2	32.8	34	17	19.9	30.2	48.3	72.1	47.4	33.6	34.9	17.4	20.4	31	49.5	73.9	74.3	-13.3	9.6	0.011	0.004	0	700



This page was intentionally left  
without important technical content.

TABLES